

aluplast GmbH (Head Office)
uPVC window profile systems
Auf der Breit 2
DE - 76227 Karlsruhe

fon: +49 721 47171-0
fax: +49 721 47171-999
info.de@aluplast.net
www.aluplast.net

aluplast Sp. z o.o.
uPVC window profile systems
ul. Golezycka 25 A
PL - 61-357 Poznan

fon: +48 61 654 3400
fax: +48 61 654 3499
aluplast@aluplast.com.pl
www.aluplast.com.pl

aluplast UK
uPVC window profile systems
Unit 1 Unit 1 Tewkesbury Industrial Estate
Green Lane | Tewkesbury
UK - Glos GL20 8HD

fon: +44 1684 273401
fax: +44 1684 273031
info@aluplast.co.uk
www.aluplast.net

IDEAL 4000[®] Casement

01 General		Page(s)	Filename(s)
01 A	Material properties	1	01_A_01_ID*
01 P	Wall Charts IDEAL 4000 casement Glazing Beads Additional Profiles 2/4 Accessories		
02 Main profiles: Overview		Page(s)	Filename(s)
02 B	Frame (Scale: 1:1)	1 - 3	02_B_01_4IDc*
	100x52 50mm (CL) Frame	1	
	100x53 60mm (CL) Frame	2	
	100x54 75mm (CL) Frame	3	
02 C	Sash (Scale: 1:1)	1 - 6	02_C_01_4IDc*
	100x55 75mm re. (CL) opening outwards, Sash	1	
	140x20 77mm re. (CL) Sash	2	
	140x30 105mm re. (CL) Sash	3	
	140x31 105mm re. (CL) opening outwards, Sash	4	
	100x50 84mm fl. (CL) Sash	5	
	100x51 62mm fl. (CL) Sash	6	
02 D	Mullions / Transoms (Scale: 1:1)	1 - 5	02_D_01_4IDc*
	100x56 70mm (CL) Mullion	1	
	100x57 70mm (CL) Mullion	2	
	100x58 80mm (CL) Mullion	3	
	100x59 80mm (CL) Mullion	4	
	140x45 104mm (CL) Transom	5	
02 E	False mullion sash / False mullion profiles	1	02_E_01_4IDc*
	140x67 64mm (SL) Big false mullion	1	

03 Main profiles: Combinations		Page(s)	Filename(s)
03 A	Construction Dimensions	1 - 4	03_A_01_4IDc*
03 C	Tilt-and-turn door thresholds	1 - 2	03_C_01_4IDc*
03 D	Frame - Sash	1 - 18	03_D_01_4IDc*
03 E	Frame - Fixed glazing	1 - 3	03_E_01_4IDc*
03 G	Sash - Mullion - Sash	1 - 6	03_G_01_4IDc*
03 H	Sash - Mullion - Fixed glazing	1 - 10	03_H_01_4IDc*
03 J	Mullion / Transom glass-dividing	1 - 3	03_J_01_4IDc*
03 L	Sash - False mullion - Sash	1 - 4	03_L_01_4IDc*

Notes to chapter 03 Combinations:

Frame ¹⁾			
Chapter	03 D	03 E	
100x52	6	1	1.
100x53	6	1	2.
100x54	6	1	3.
Pages	18	3	

Mullion ¹⁾				
Chapter	03 G	03 H		
100x56	2	2	1.	
100x57	-	2	2.	
100x58	2	2	3.	
100x59	-	2	4.	
140x45	2	2	5.	
Pages	6	10		

Mullions/Transoms ¹⁾		
Chapter	03 J	
100x56	1	1.
100x58	1	2.
140x45	1	3.
Pages	3	

Sash ²⁾	
Chapter	
100x50	1.
100x51	2.
100x55	3.
140x20	4.
140x30	5.
140x31	6.

False mullion ¹⁾	
Chapter	03 L
140x67	4
Pages	4

1) The profiles are sorted numerically within the chapters.
2) The sashes are sorted numerically within the profile chapters.

04	Additional profiles		Page(s)	Filename(s)
...	Refer to manual "Additional Profiles / Accessories"			
04 L	Bay Window / Angle assembly details	(Scale: 1:1)	1 - 6	04_L_01_4IDc*
...	Refer to manual "Additional Profiles / Accessories"			
05	Accessories		Page(s)	Filename(s)
	Refer to manual "Additional Profiles / Accessories"			
06	Reinforcement Guidelines / Statics		Page(s)	Filename(s)
	See manual "Handling"			
07	- - -		Page(s)	Filename(s)
	Currently not available!			
08	General Processing Guidelines		Page(s)	Filename(s)
	See manual "Handling"			
09	Individual Handling		Page(s)	Filename(s)
09 H	Mechanical Connections		1	09_H_01_4IDc*
09 X	Cutting Details		1 - 17	09_X_01_4IDc*
10	General Installation Guidelines		Page(s)	Filename(s)
	See manual "Handling"			

Abbreviations (not all necessarily used in all profile series):

Design / Style: (CL) Classic-line / (SL) Soft-line / (RL) Round-line / (HL) Historik-line
 Profile type: (MB) Monoblock or block profile: Frame group(s) with integrated door case
 Regional profiles: (CH) Switzerland / (NL) Netherlands
 Sash position in frame: re. recessed / s.re. semi-recessed / fl. flush

Material Properties

In compliance with the DIN EN ISO 1163 standard, aluplast uses the following uPVC moulding compound as material for the profile systems:

ISO 1163 - PVC-U, EDLP, 082-50-T28

Iso standard DIN EN ...

PVC = polyvinyl chloride

U = plasticiser-free (rigid)

E = extrusion

D = powder (Dryblend)

L = light and weathering stabiliser

P = impact-resistant modified

082 = 80 - 84 °C = Vicat-softening temperature

50 = >40 kJ/m² = impact strength

T28 = 2500 - 3000 N/mm² = modulus of elasticity (tensile modulus = tension = T)

The formulation used is free of cadmium and barium.

Other versions / consignments according to system description or on request.

Characteristics CaZn (calcium zinc)

according to standard(s)	Description	Result	Unit
DIN EN ISO 306	dimensional stability under heat Vicat-softening temperature VST/B 50	80 ± 2	°C
DIN EN ISO 179-1 / 1eA / 1eC / 1fC	double-v impact strength a _v (RAL-toughness) Charpy / test bar according to RAL	Ø ≥ 40 no value below 20	kJ/m ² at + 23 °C
DIN EN ISO 178 / 527-1 + 527-2	flexural modulus E _f / tensile modulus E _t	2800	N/mm ²
DIN EN ISO 182-2 / DIN 53 381-1	stability time t _{St} pH-measurement methods, oil bath / conductivity measurement methods	40 ± 6	minutes at + 200 °C

General characteristics of uPVC

according to standard(s)	Description	Result	Unit
DIN 53752 Leitz-dilatometer	coefficient of linear expansion from -30 °C to +50 °C	7 x 10 ⁻⁵	1/K
DIN 52612-1/-2/-3 guarded hot plate method	thermal conductivity	λ (Lambda) 0.16	W/mK
DIN 4102-1	fire performance uPVC flat profiles	B1	-
DIN 4102-1	fire performance uPVC hollow chamber profiles	B2	-
DIN EN 13501-1	fire performance uPVC	E	-

Main Profiles

Frame

Sash

Mullion

Transoms

False mullion

Flush-Sash

Accessories

AI Spacer

AI End caps

AI Ramp end cap

AI Weather bar end caps

AI Sill end caps

AI Connector without sticks

AI IFI Reinforcements (...)= Ix, ly

IGI Nipple screw / Clip

IJI Lifter

IJI Bonding of pane

IFI Reinforcements (...)= Ix, ly

(0.4)209014 s=1.5
-> 100x56 aluminium

(6.9/5.5)249031 s=2.0
-> 140x30, 140x31

(0.5)209015 s=1.5
-> 100x58 aluminium

(6.1/5.2)249034 s=1.25
-> 140x45

(1.2/0.7)209026 s=3.0
-> 100x20, 100x21, 100x22

(9.2/7.8)249035 s=2.0
-> 140x45

(2.3/0.9)229023 s=1.5
-> 140x20

(3.4/2.1)259906 s=2.0
-> 100x54

(1.6/0.6)229025 s=1.0
-> 140x20

(3.1/0.4)259094 s=2.0
-> 140x67

(3.0/1.1)229024 s=1.5
-> 140x20

(3.8/1.5)229026 s=2.0
-> 140x20

(0.4/0.34)209051 s=1.0
-> 100x51

(2.5/1.7)229029 s=1.25
(3.7/2.5)229030 s=2
-> 100x50

(1.7/0.6)229027 s=1.5
(2.1/0.8)229028 s=2.0
-> 140x20

(4.0/5.0)229114 s=1.5
-> 140x30, 140x31

(6.4/5.0)229115 s=2.0
-> 140x30, 140x31

(0.9/1.3)229117 s=2.0
-> 100x53

(0.7/1.0)229119 s=1.5
-> 100x53

(7.9/7.1)249013 s=2.0
-> 140x31

(5.1/2.1)249026 s=3.0
-> 140x20

(1.6)209003 s=1.5
-> 100x58, 100x59

(0.7/0.2)209005 s=1.5
-> 100x55

(2.2)209009 s=2.5
-> 100x54, 100x56, 100x57

(4.0)209010 s=2.5
-> 100x58, 100x59

PI Aluskin Aluminium shells

SL 90 mm AU 175 mm

209353 (CL)
-> 100x53 (CL)

SL 105 mm AU 205 mm

209354 (CL)
-> 100x54 (CL)

SL 111 mm AU 217 mm

209355 (CL)
-> 100x55 (CL)

SL 116 mm AU 227 mm

209358 (CL)
-> 100x58 (CL)

SL 102 mm AU 199 mm

209350 (CL)
-> 100x50 (CL)

SL 80 mm AU 155 mm

209351 (CL)
-> 100x51 (CL)

SL 55 mm AU 105 mm

209452 (CL)
-> 100x52 (CL)
-> 100x56 (CL)

SL 88 mm AU 166 mm

249450 (CL)
-> 140x20 (CL)

SL 116 mm AU 222 mm

249460 (CL)
-> 140x30 (CL)

SL 125 mm AU 175 mm

209453 (CL)
-> 100x53 (CL)
-> 100x58 (CL)

SL 80 mm AU 155 mm

209454 (CL)
-> 100x54 (CL)

SL 89 mm AU 173 mm

249443 (CL)
-> 140x45 (CL)

Additional Profiles

Couplings

Exterior window sills

Cover strip

Weather Bar

ISI Aluminium profiles

Bay window, alum. profiles

IUI Aluminium threshold

ISI Aluminium ramp

ITI Aluminium weather bar

Glazing Beads

120836 bl
120866 pw
Glazing -> 24 mm

120636 bl
120666 pw
Glazing -> 28 mm

120832 bl
120862 pw
Glazing -> 36 mm

140631 bl
140661 pw
Glazing -> 40 mm

IXI Gaskets

IXI 459951 bl or IXI 449986 bl
-> Glazing

IXI 429320 bl or IXI 449346 bl
-> Stop

IXI 409051 bl
-> 100x50, 100x51

IXI 409104
ITI 20x104

IXI 409050
-> Frame

ISI Bonding of pane

1) or

2)

ISI Aluminium threshold

20x101 Silver -> 207101 (x 3 m)
Gold -> 202101 (x 3 m)
Black -> 203101 (x 3 m)

ISI Aluminium ramp

20x102 Silver -> 207102 (x 3 m)
Gold -> 202102 (x 3 m)
Black -> 203102 (x 3 m)

ITI Aluminium weather bar

209044 White -> 200104 (x 3 m)
Black -> 203104 (x 3 m)
Silver -> 207104 (x 3 m)
Brown -> 201104 (x 3 m)
Caramel -> 205104 (x 3 m)

ISI not laminated SL visible length
ISI laminated AU exterior perimeter

-> for SL: AU:

bl black
pw papyrus-white

(CL) Classic-line
(SL) Soft-line

a	e.g. Profile serial	c ³⁾	d	Glazing thickness																		
85mm	IDEAL 7000 + 16mm + 4mm protrusion	->170x39		38 - 39mm	40 - 41mm	42 - 43mm	44 - 45mm	46 - 47mm	48 - 49mm	50 - 51mm	52 - 53mm	54 - 55mm	56 - 57mm	58 - 59mm	60 - 61mm	62 - 63mm	64 - 65mm	66 - 67mm	68 - 69mm	70 - 71mm	72 - 73mm	74 - 75mm
81mm	IDEAL 7000 + 16mm + 0mm protrusion	->170x39		34 - 35mm	36 - 37mm	38 - 39mm	40 - 41mm	42 - 43mm	44 - 45mm	46 - 47mm	48 - 49mm	50 - 51mm	52 - 53mm	54 - 55mm	56 - 57mm	58 - 59mm	60 - 61mm	62 - 63mm	64 - 65mm	66 - 67mm	68 - 69mm	70 - 71mm
73mm	IDEAL 8000 + 8mm / 180250	->180x26, 180x47, 180x69		22 - 23mm	24 - 25mm	26 - 27mm	28 - 29mm	30 - 31mm	32 - 33mm	34 - 35mm	36 - 37mm	38 - 39mm	40 - 41mm	42 - 43mm	44 - 45mm	46 - 47mm	48 - 49mm	50 - 51mm	52 - 53mm	54 - 55mm	56 - 57mm	58 - 59mm
67mm	energeto 5000 view Sash	->150x80					24 - 25mm	26 - 27mm	28 - 29mm	30 - 31mm	32 - 33mm	34 - 35mm	36 - 37mm	38 - 39mm	40 - 41mm	42 - 43mm	44 - 45mm	46 - 47mm	48 - 49mm	50 - 51mm	52 - 53mm	54 - 55mm
65mm	IDEAL 7000, IDEAL 8000, Nord-line	Frame, lift-slide ⁴⁾																				
63mm	IDEAL 5000 + 8mm / 180250	->150x27																				
55mm	IDEAL 4000, IDEAL 5000, Nord-line	Sash, smart-slide ^{5) 6)}																				
47mm	IDEAL 2000, multi-slide ⁵⁾																					
32mm	easy-slide ⁵⁾	easy-slide ⁶⁾ ->100078																				
20/22mm	mono-slide ^{5) 6)}																					

b	Glazing Beads	46mm	44mm	42mm	40mm	38mm	36mm	34mm	32mm	30mm	28mm	26mm	24mm	22mm	20mm	18mm	16mm	14mm	12mm	10mm
(CL) Classic-line																				
h = 20mm ^{1) 2)}	black [mm]	140741 [6]	140841 [4]	140641 [2]	120740 [6]	120840 [4]	120640 [2]	120738 [6]	120838 [4]	120638 [2]	120736 [6]	120836 [4]	120636 [2]	120835 [4]	120635 [2]	120833 [4]	120633 [2]	120832 [4]	120632 [2]	140631 [4]
	papyrus-white [mm]	140771 [6]	140871 [4]	140671 [2]	120770 [6]	120870 [4]	120670 [2]	120768 [6]	120868 [4]	120668 [2]	120766 [6]	120866 [4]	120666 [2]	120865 [4]	120665 [2]	120863 [4]	120663 [2]	120862 [4]	120662 [2]	140661 [4]
h = 30mm ²⁾	black [mm]	-	-	-	-	-	-	-	-	-	-	-	-	-	-	-	-	-	-	-
	papyrus-white [mm]	-	-	-	-	-	-	-	-	-	-	-	-	-	-	-	-	-	-	-
(RL) Round-line																				
h = 20mm ^{1) 2)}	black [mm]					140854 [2.5]	140654 [0.5]					120850 [4]	120650 [2]	120859 [3-4]	120659 [2-3]	140852 [3-4]	120642 [2-3]			
	papyrus-white [mm]					140884 [2.5]	140684 [0.5]					120880 [4]	120680 [2]	120889 [3-4]	120689 [2-3]	140882 [3-4]	120672 [2-3]			
h = 30mm ²⁾	black [mm]					-	-					-	-	-	-	-	-			
	papyrus-white [mm]					-	-					-	-	-	-	-	-			
(SL) Soft-line																				
h = 20mm ^{1) 2)}	black [mm]									120855 [4]		120846 [4]	120646 [2]	120847 [4]	120647 [2]	120851 [4]	120651 [2]	120849 [4]	120649 [2]	
	papyrus-white [mm]									120885 [4]		120876 [4]	120676 [2]	120877 [4]	120677 [2]	120881 [4]	120681 [2]	120879 [4]	120679 [2]	
h = 30mm ²⁾	black [mm]									-		130856 [4]	130656 [2]	130857 [4]	130657 [2]	130858 [4]	130658 [2]	130859 [4]	130659 [2]	
	papyrus-white [mm]									-		130886 [4]	130686 [2]	130887 [4]	130687 [2]	130888 [4]	130688 [2]	130889 [4]	130689 [2]	

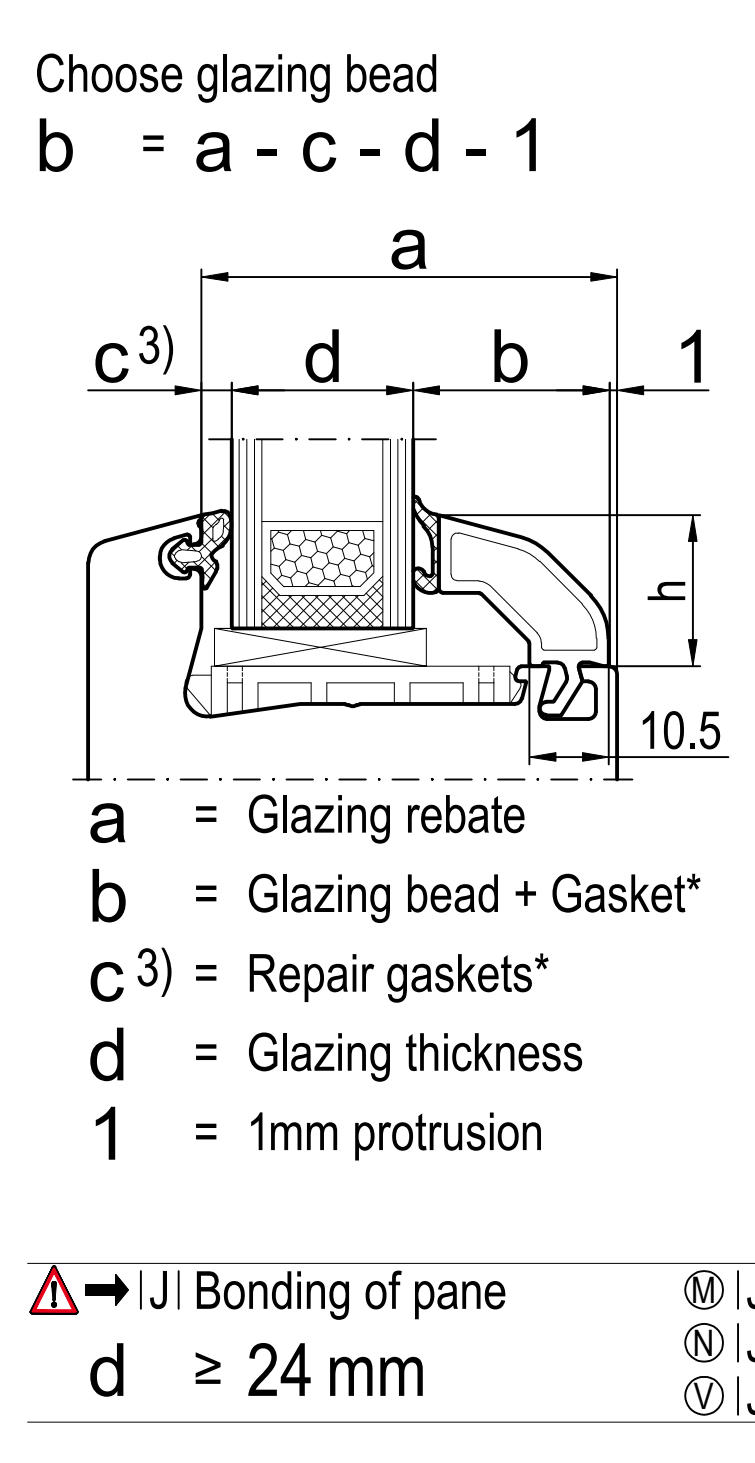

i compressed gasket

- for backstop gasket systems
- for centre gasket systems
- or profile with gasket
- Sash (Lift-and-slide door)
- Sash (Sliding window)
- Frame (Sliding window)

□ not laminated
■ laminated

IP Aluskin Aluminium shells
-> for

(CL) Classic-line
(RL) Round-line
(SL) Soft-line

bl black ~ RAL 9005
pw papyrus-white ~ RAL 9018
oc ochre

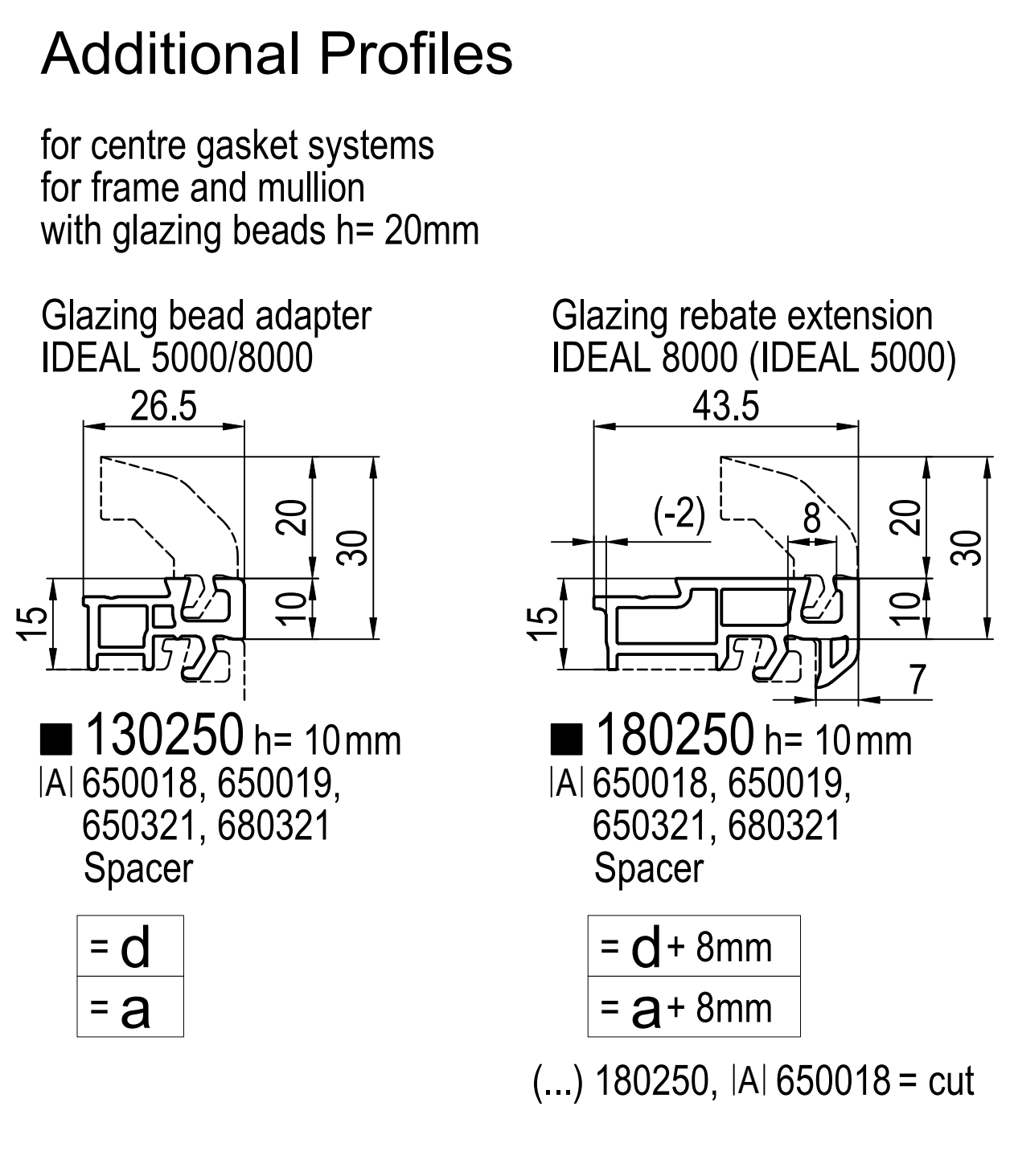

Repair gaskets

IXI Gaskets
-> Main Profiles

Glazing thickness	= d	Standard	= d	Option	= d	Option	= d	Option	x	x	x	x	= d - 2mm
IDEAL 2000, multi-slide ⁵⁾													
IDEAL 4000, IDEAL 5000, IDEAL 7000, IDEAL 8000, Nord-line, lift-slide ⁴⁾ , smart-slide ^{5) 6)} , IDEAL 2000 + 8mm	x	= d + 1mm	= d + 1mm	= d + 1mm	= d	Standard	= d	Option	= d	IP Aluskin	= d	IP Aluskin	= d - 1mm
easy-slide ⁵⁾	x	= d	Standard	= d	Option	= d	Option	= d - 1mm	= d - 1mm	x	x	x	= d - 2mm
mono-slide ⁵⁾	x	= d + 2mm	= d + 2mm	= d + 2mm	= d + 1mm	= d + 1mm	x	x	x	x	x	x	= d Standard
easy-slide ⁶⁾ , mono-slide ⁶⁾	x	= d	Option	= d	Standard	= d	Option	= d - 1mm	= d - 1mm	x	x	x	= d - 2mm
		[2.5-3.5]	[2.5-3.5]	[3-3.5]	[3-5]	[4-4.5]	[4-4.5]	[4]	[4]	[4.5-7.0]			

IXI Gaskets
-> Glazing Beads

Compression [mm]	429921 bl	459922 bl	409076 bl	459925 bl	479015 bl	449980 bl	459951 bl	449986 bl	459923 bl
	429921 pw	- pw	- pw	450925 pw	477015 pw	447980 pw	- pw	447986 pw	- pw
	- oc	- oc	- oc	453925 oc	- oc	- oc	- oc	- oc	- oc
C = 3mm	C = 3mm	C = 3mm	C = 3mm	C = 3mm	C = 4mm	C = 4mm	C = 4mm	C = 4mm	C = 5mm

Standard -> IP
Option -> IP

Extensions

120227 ->60/70mm
140227 ->70mm
180227 ->85mm
120220 ->60/70mm
140209 ->70mm
180209 ->85mm
120242 ->60/70mm
140205 ->70/85mm
180201 ->85mm
120221 ->60/70mm
140207 ->70/85mm
180203 ->85mm
140208 ->70/85mm
180204 ->85mm
140206 ->70/85mm
180222 ->85mm

Couplings

120116
120224
449140 = IXI Gaskets
120240 ->60/70mm
120241 ->60/70mm
120243 ->70mm
140203 ->70mm
140267 ->70mm
180267 ->85mm
140244 ->70/85mm
120275 90° ->60mm
140248 90° ->60/70/85mm
140249 135° ->60/70/85mm

Structural profiles

120224 ->85mm
120219 ->60/70/85mm
140267 ->70mm
180267 ->85mm
140218 ->60mm
140218 ->70mm
180218 ->85mm

Accessories

640302 2x50x100 mm -> Couplings
249335 (CL) -> 120242, 140205, 180201
249360 (CL) -> 120221, 140207, 180203
249310 (CL) -> 140208, 180204
289210 (CL) -> 120211
289211 (CL) -> 120211

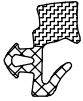

IPI 459951 bl -> IPI or IPI 449986 bl -> IPI
-> Glazing Gasket



IPI 449986 bl -> IPI
-> Glazing Gasket

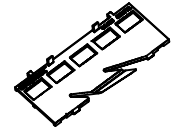

IAI 602013
Spacer



IPI 429320 bl -> IPI or IPI 449346 bl -> IPI
-> Stop Gasket



IPI 449346 bl -> IPI
-> Stop Gasket

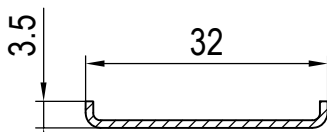
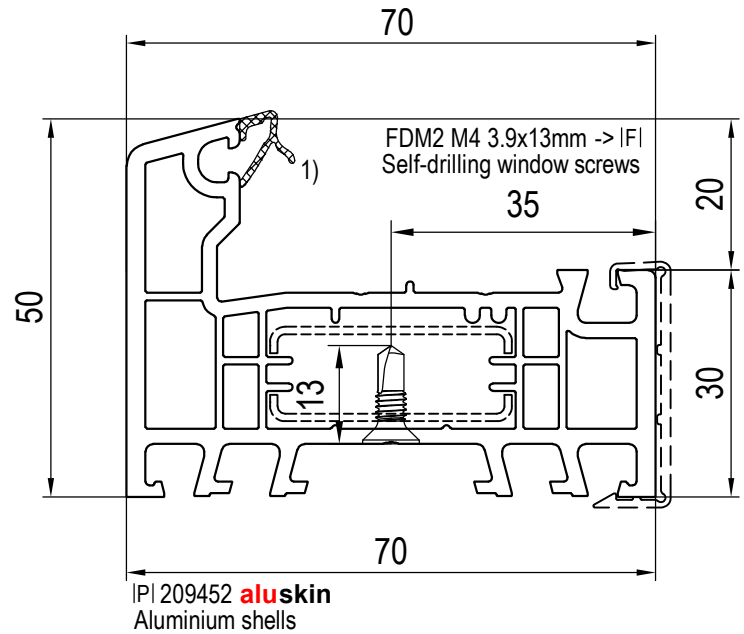

IPI 209001 s=1.0mm 0.4cm⁴
Reinforcements

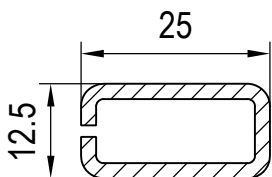

IPI 229106 s=2.0mm 0.8cm⁴
Reinforcements

1) Pre-inserted gasket(s): Please refer to valid price list.

scale 1:1

02_B_01_4IDc*

en May be subject to change and errors excepted!

Classic-line (CL)

frame - dormant - telaio - marco - Rahmen

Main Profiles: Frames
Frame 50mm: 100x52

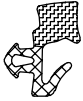

IXI 459951 bl -> IPI
-> Glazing
Gasket



IXI 449986 bl -> IPI
-> Glazing
Gasket

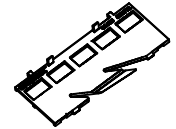

IAI 602013
Spacer



IXI 429320 bl -> IPI
-> Stop
Gasket



IXI 449346 bl -> IPI
-> Stop
Gasket

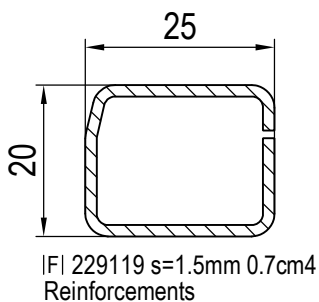
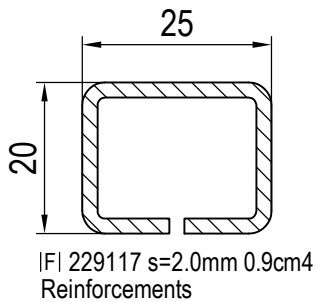
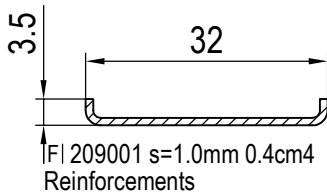
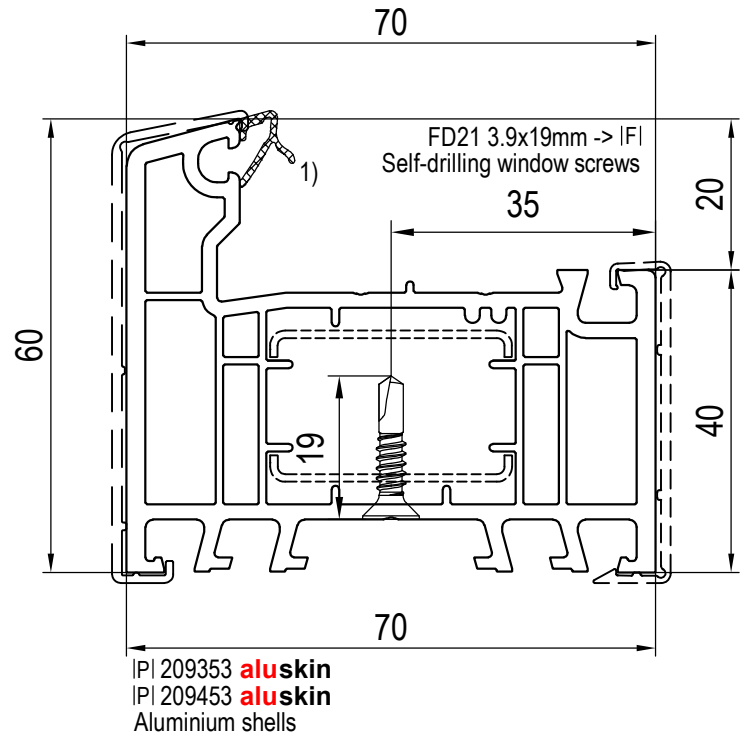

1) Pre-inserted gasket(s): Please refer to valid price list.

scale 1:1

02_B_01_4IDc*

en May be subject to change
and errors excepted!

Classic-line (CL)

frame - dormant - telaio - marco - Rahmen

Main Profiles: Frames
Frame 60mm: 100x53

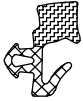

IXI 459951 bl -> |PI| or IXI 449986 bl -> |PI|
-> Glazing Gasket



-> Glazing Gasket

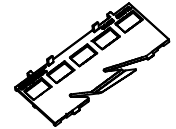

IAI 602013
Spacer



IXI 429320 bl -> |PI| or IXI 449346 bl -> |PI|
-> Stop Gasket



-> Stop Gasket

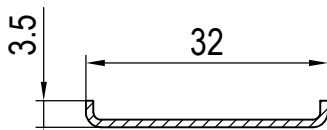

IFI 209001 s=1.0mm 0.4cm⁴
Reinforcements

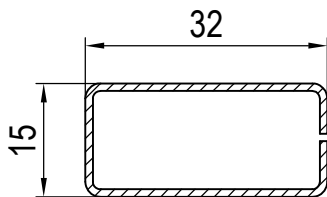

IFI 209002 s=1.5mm 1.1cm⁴
Reinforcements

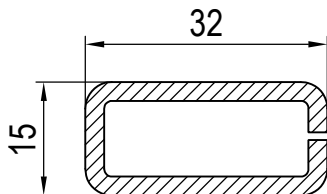

IFI 209009 s=2.5mm 2.2cm⁴
Reinforcements

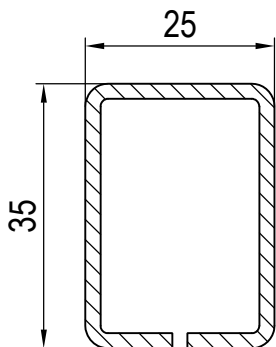

IFI 259906 s=2.0mm 2.1cm⁴
Reinforcements

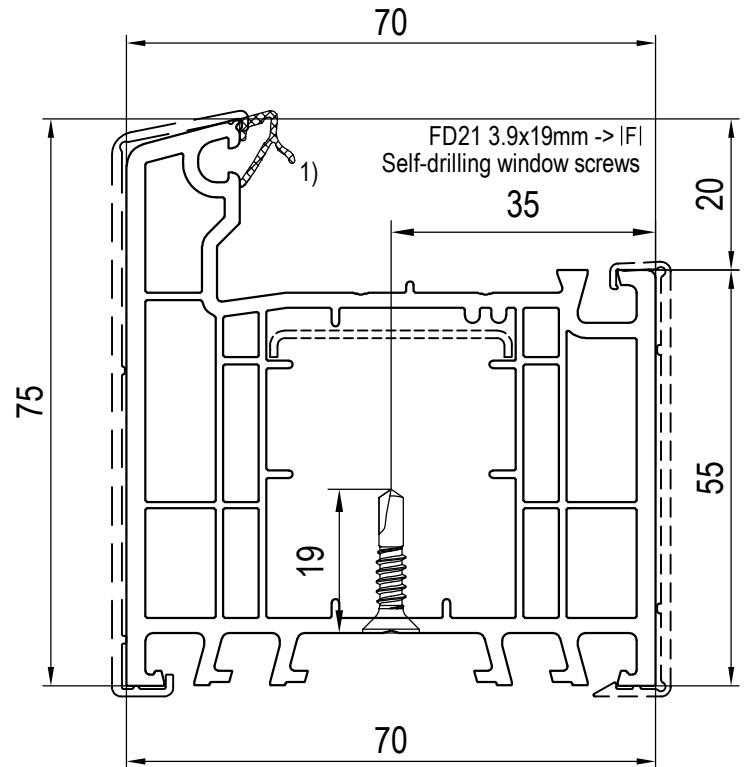

|PI| 209354 **aluskin**
|PI| 209454 **aluskin**
Aluminium shells

1) Pre-inserted gasket(s): Please refer to valid price list.

scale 1:1

02_B_01_4IDc*

en May be subject to change and errors excepted!

Classic-line (CL)

frame - dormant - telaio - marco - Rahmen

Main Profiles: Frames
Frame 75mm: 100x54

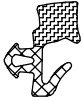

IXI 459951 bl -> IPI
-> Glazing
Gasket



IXI 449986 bl -> IPI
-> Glazing
Gasket



IXI 429320 bl -> IPI
-> Stop
Gasket



IXI 449346 bl -> IPI
-> Stop
Gasket

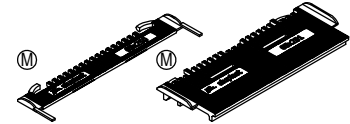

IAI 650250
Spacer
t = -1mm

IAI 650251
t = 5mm

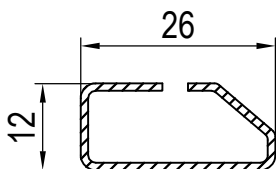
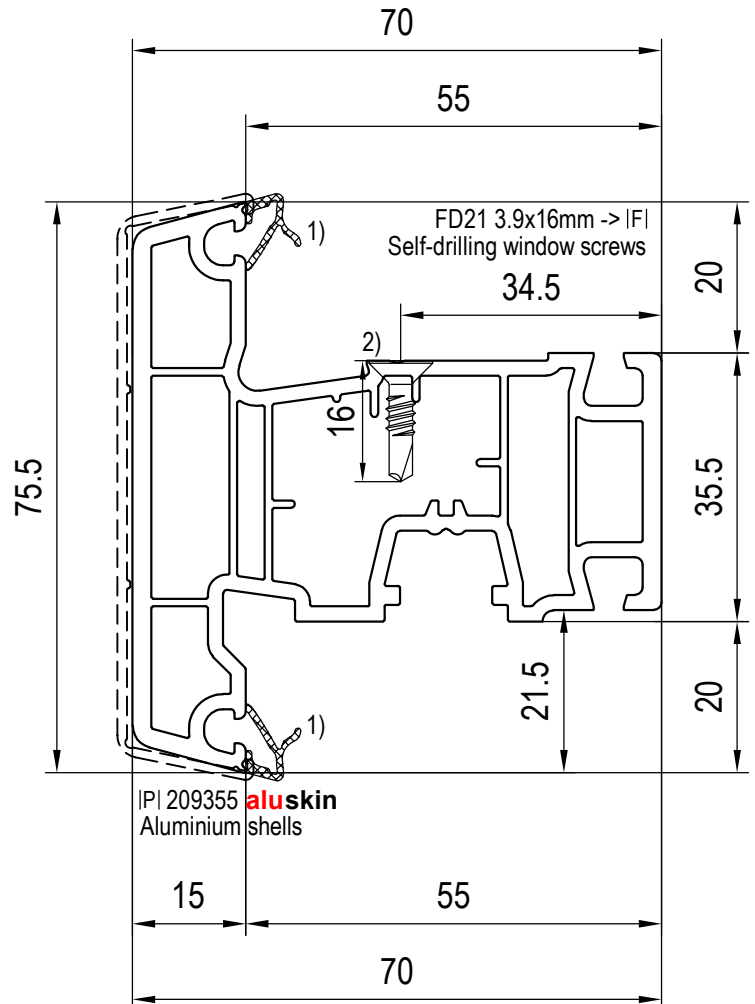

IFI 209005 s=1.5mm 0.7/0.2cm4
Reinforcements

- 2) Seal the screw heads in the bottom horizontal rebate.
1) Pre-inserted gasket(s): Please refer to valid price list.

sash - ouvrant - anta - hoja - Flügel

scale 1:1

02_C_01_4IDc*

en May be subject to change
and errors excepted!

Classic-line (CL)

Main Profiles: Sashes
T-Sash 75mm: 100x55

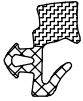

IXL 459951 bl -> |PI| or IXL 449986 bl -> |PI|
-> Glazing Gasket



IXL 449986 bl -> |PI|
-> Glazing Gasket



IXL 429320 bl -> |PI| or IXL 449346 bl -> |PI|
-> Stop Gasket



IXL 449346 bl -> |PI|
-> Stop Gasket

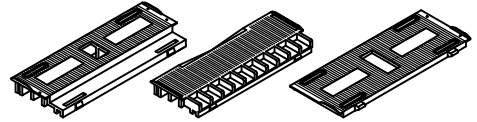

IAl 640311 Spacer t = 5mm 10-25mm
IAl 640320 t = 5mm 10-41mm
IAl 640301 t = 0mm 10-41mm Glazing

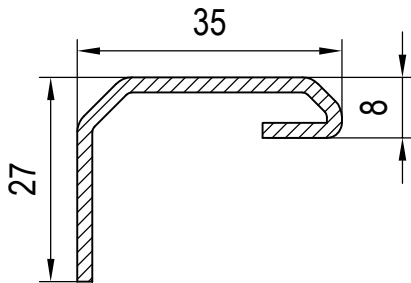

IFI 229027 s=1.5mm 1.7cm⁴
IFI 229028 s=2.0mm 2.1cm⁴
Reinforcements

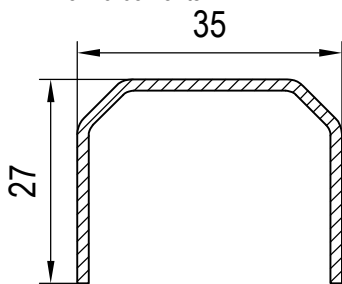

IFI 229023 s=1.5mm 2.3cm⁴
IFI 229025 s=1.0mm 1.6cm⁴
Reinforcements

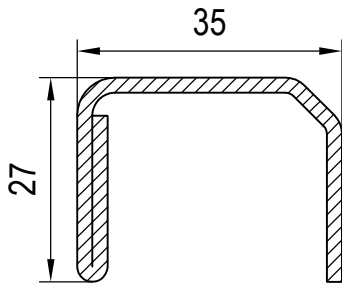

IFI 229024 s=1.5mm 3.0cm⁴
IFI 229026 s=2.0mm 3.8cm⁴
IFI 249026 s=3.0mm 5.1cm⁴
Reinforcements

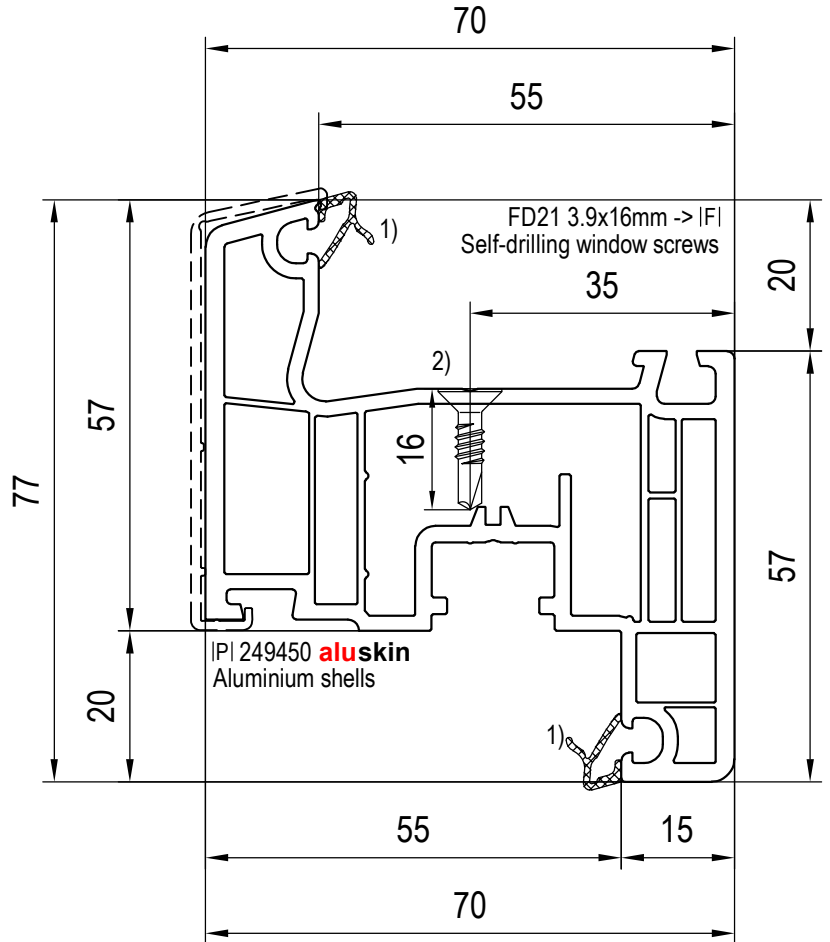

2) Seal the screw heads in the bottom horizontal rebate.
1) Pre-inserted gasket(s): Please refer to valid price list.

sash - ouvrant - anta - hoja - Flügel

scale 1:1

02_C_01_4IDc*

en May be subject to change and errors excepted!

Classic-line (CL)

Main Profiles: Sashes
Sash, recessed 77mm: 140x20

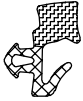

IXL 459951 bl -> |PI|
-> Glazing
Gasket



IXL 449986 bl -> |PI|
-> Glazing
Gasket



IXL 429320 bl -> |PI|
-> Stop
Gasket



IXL 449346 bl -> |PI|
-> Stop
Gasket

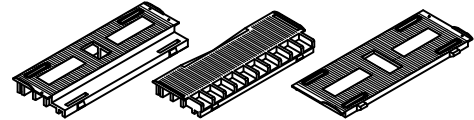

IAl 640311
Spacer
t = 5mm
10-25mm

IAl 640320
t = 5mm
10-41mm

IAl 640301
t = 0mm
10-41mm Glazing

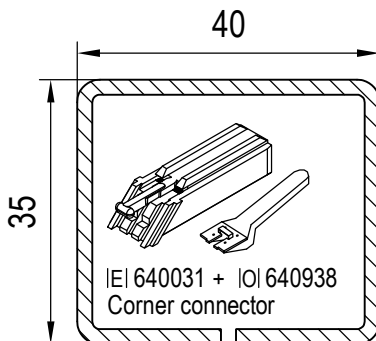
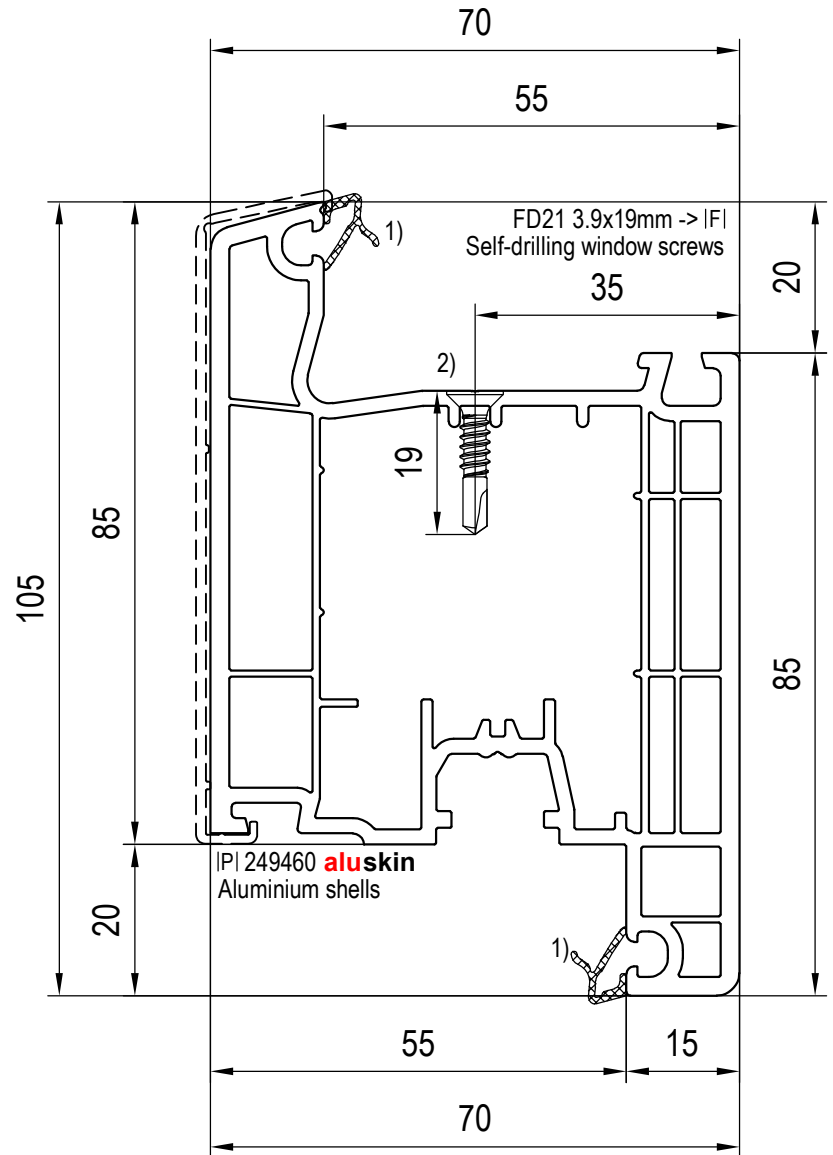

IFI 229114 s=1.5mm 5.0cm4
IFI 229115 s=2.0mm 6.4cm4
Reinforcements

2) Seal the screw heads in the bottom horizontal rebate.
1) Pre-inserted gasket(s): Please refer to valid price list.

sash - ouvrant - anta - hoja - Flügel

scale 1:1

02_C_01_4IDc*

en May be subject to change and errors excepted!

Classic-line (CL)

Main Profiles: Sashes
Sash, recessed 105mm: 140x30

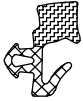

IXL 459951 bl -> IPI
-> Glazing
Gasket



IXL 449986 bl -> IPI
-> Glazing
Gasket



IXL 429320 bl -> IPI
-> Stop
Gasket



IXL 449346 bl -> IPI
-> Stop
Gasket

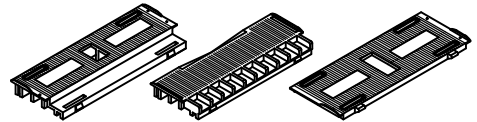

IAI 640311
Spacer
t = 5mm
10-25mm

IAI 640320
t = 5mm
10-41mm

IAI 640301
t = 0mm
10-41mm Glazing

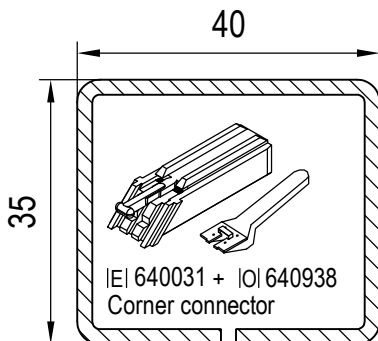
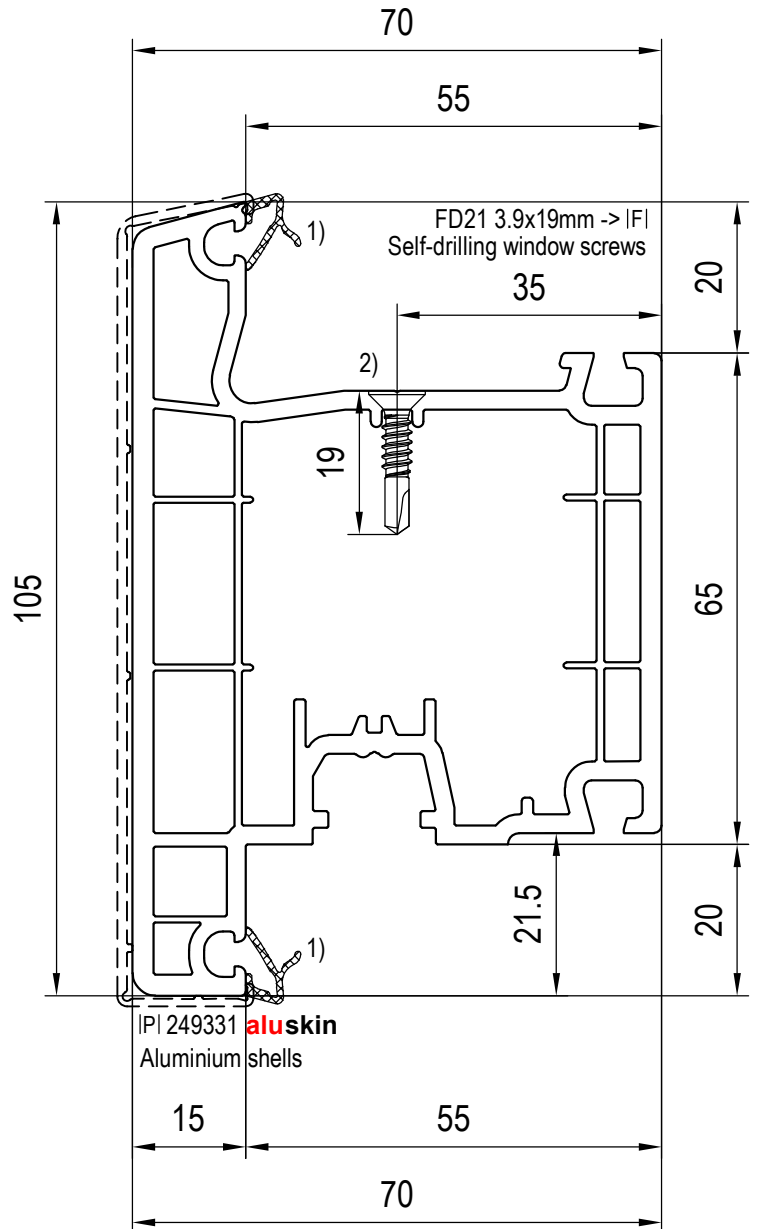

IFI 229114 s=1.5mm 5.0cm4
IFI 229115 s=2.0mm 6.4cm4
Reinforcements

2) Seal the screw heads in the bottom horizontal rebate.
1) Pre-inserted gasket(s): Please refer to valid price list.

sash - ouvrant - anta - hoja - Flügel

scale 1:1

02_C_01_4IDc*

en May be subject to change
and errors excepted!

Classic-line (CL)

Main Profiles: Sashes
T-Sash 105mm: 140x31

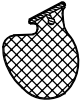

IXI 409051 bl -> IPI
-> Stop
Gasket

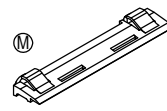

IJI 642262 bl
Bonding of pane

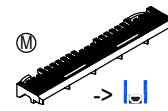

IJI 642261 bl

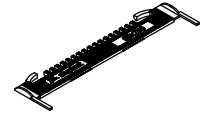

IAI 650250
Spacer
t = -1mm

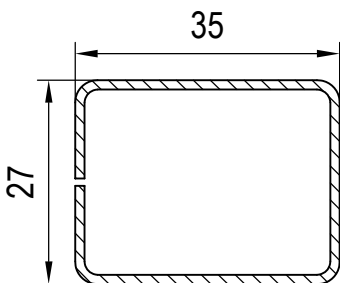
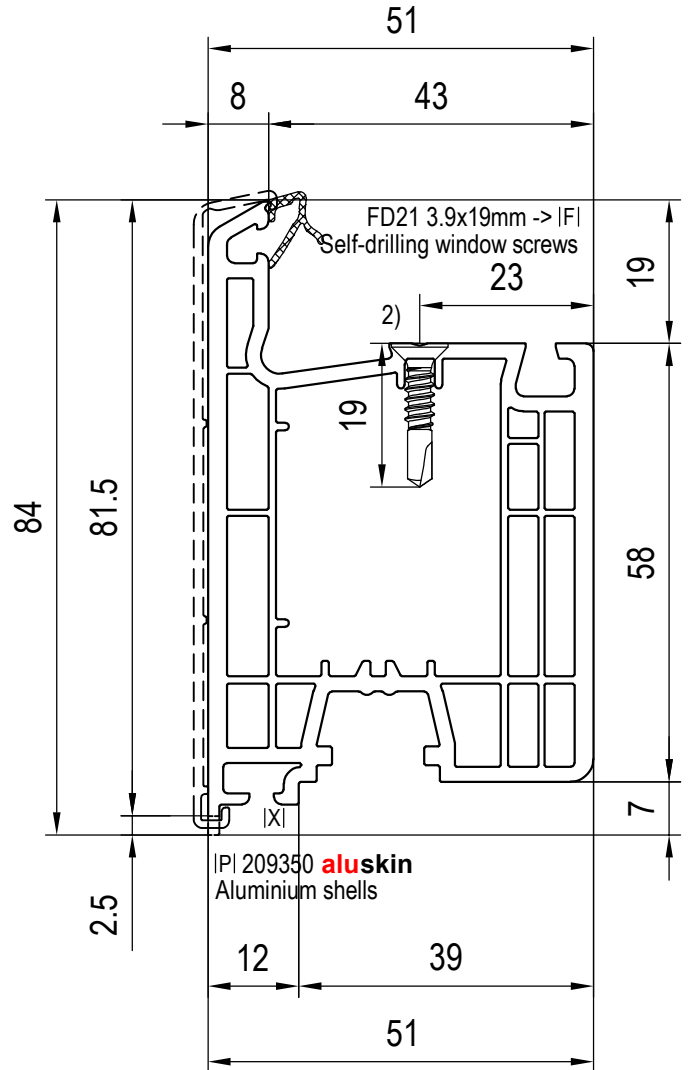

IFI 229029 s=1.25mm 2.5/1.7cm4
IFI 229030 s=2.0mm 3.7/2.5cm4
Reinforcements

- 2) Seal the screw heads in the bottom horizontal rebate.
- 1) Pre-inserted gasket(s): Please refer to valid price list.

sash - ouvrant - anta - hoja - Flügel

scale 1:1

02_C_01_4IDc*

en May be subject to change and errors excepted!

Classic-line (CL)

Main Profiles: Sashes
Flush-Sash 84mm: 100x50

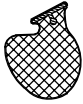

IXI 409051 bl -> |PI|
-> Stop
Gasket

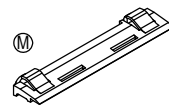

IJI 642262 bl
Bonding of pane

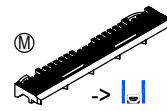

IJI 642261 bl

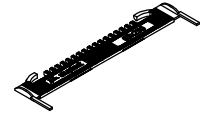

IAI 650250
Spacer
t = -1mm

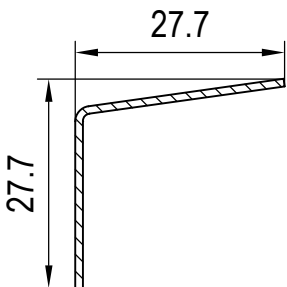
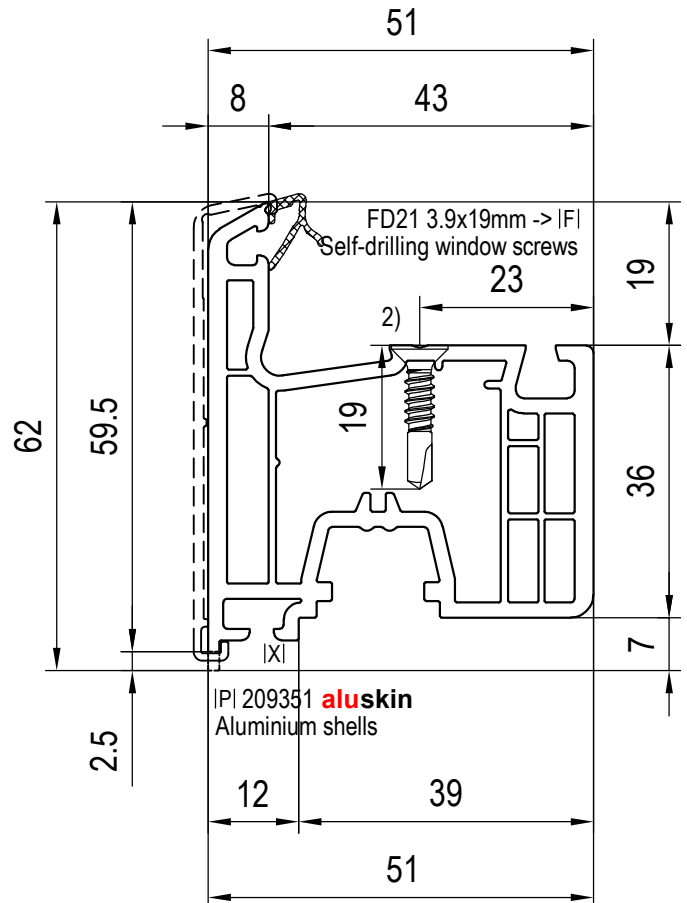

|FI| 209051 s=1.0mm 0.4/0.34cm4
Reinforcements

- 2) Seal the screw heads in the bottom horizontal rebate.
1) Pre-inserted gasket(s): Please refer to valid price list.

sash - ouvrant - anta - hoja - Flügel

scale 1:1

02_C_01_4IDc*

en May be subject to change
and errors excepted!

Classic-line (CL)

Main Profiles: Sashes
Flush-Sash 62mm: 100x51



|X| 459951 bl -> |P| or |X| 449986 bl -> |P|
-> Glazing Gasket



|X| 449986 bl -> |P|
-> Glazing Gasket

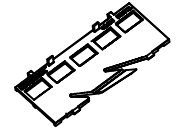

|A| 602013
Spacer



|X| 429320 bl -> |P| or |X| 449346 bl -> |P|
-> Stop Gasket



|X| 449346 bl -> |P|
-> Stop Gasket

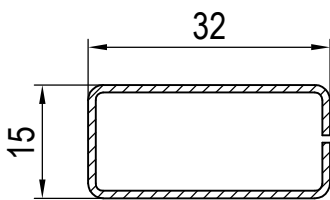
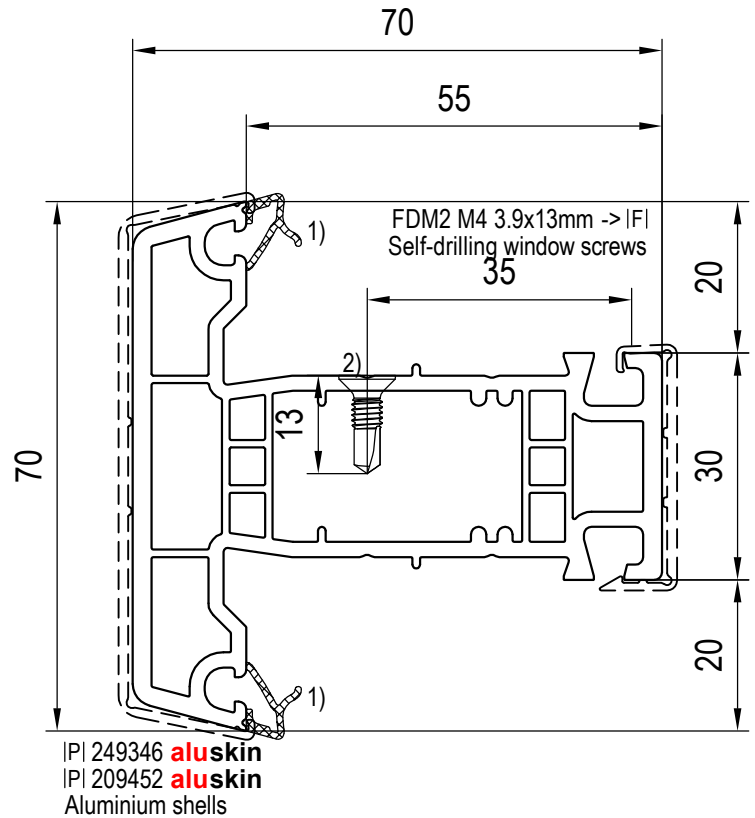

|F| 209002 s=1.5mm 1.1cm⁴
Reinforcements

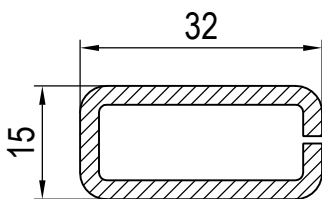

|F| 209009 s=2.5mm 2.2cm⁴
Reinforcements

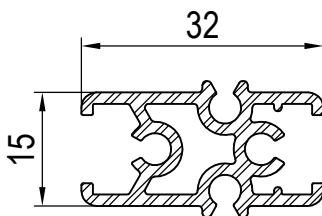

|F| 209014 s=1.5mm 0.4cm⁴
Reinforcements
aluminium

2) Seal the screw heads in the bottom horizontal rebate.
1) Pre-inserted gasket(s): Please refer to valid price list.

mullion - meneau - montante - poste - Pfosten
transom - traverse - traverso - travesaño - Sprosse

scale 1:2, 1:1

02_D_01_4IDc*

en May be subject to change and errors excepted!

Classic-line (CL)

Main Profiles: Mullions / Transoms
Mullions/Transoms 70mm: 100x56

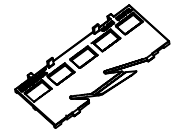

IA 602013
Spacer

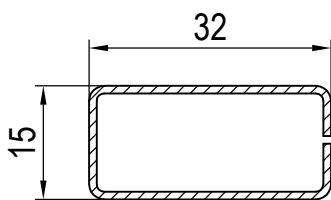
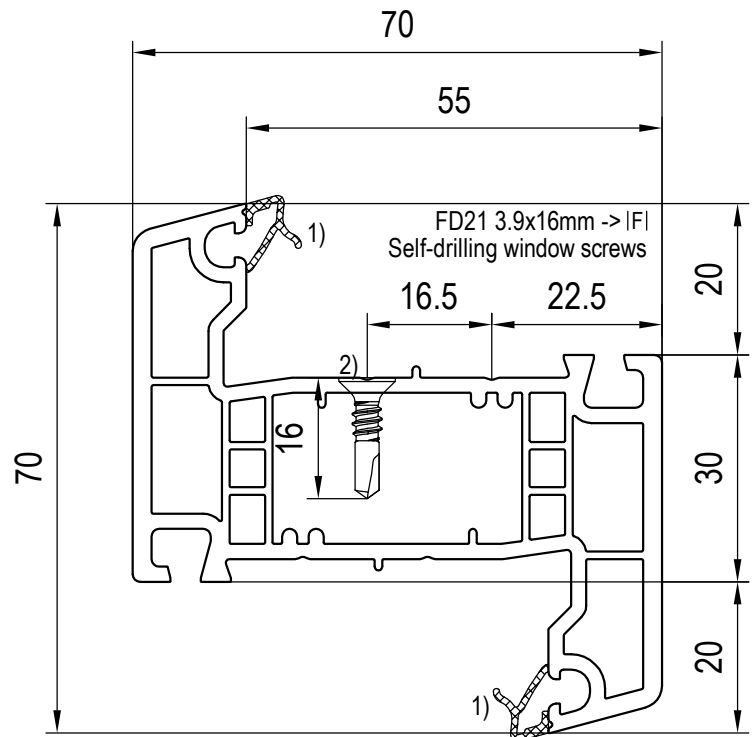

IFI 209002 s=1.5mm 1.1cm⁴
Reinforcements

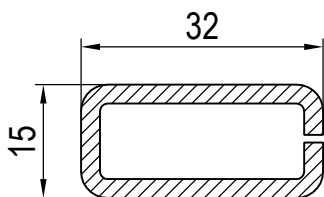

IFI 209009 s=2.5mm 2.2cm⁴
Reinforcements

- 2) Seal the screw heads in the bottom horizontal rebate.
1) Pre-inserted gasket(s): Please refer to valid price list.

Z-mullion - meneau "Z" - montante "Z" - poste en "Z" - Z-Pfosten
Z-transom - traverse "Z" - traverso "Z" - travesaño en "Z" - Z-Sprosse

scale 1:2, 1:1

02_D_01_4IDc*

en May be subject to change
and errors excepted!

Classic-line (CL)

Main Profiles: Mullions / Transoms
Z-mullion, 70mm: 100x57



IXI 459951 bl -> |P| or IXI 449986 bl -> |P|
-> Glazing Gasket



IXI 449986 bl -> |P|
-> Glazing Gasket

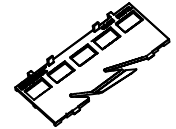

IAI 602013
Spacer



IXI 429320 bl -> |P| or IXI 449346 bl -> |P|
-> Stop Gasket



IXI 449346 bl -> |P|
-> Stop Gasket

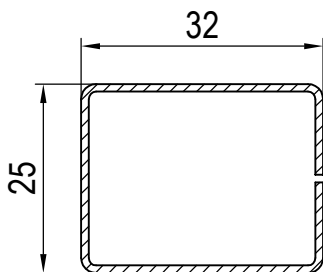

IFI 209003 s=1.5mm 1.6cm⁴
Reinforcements

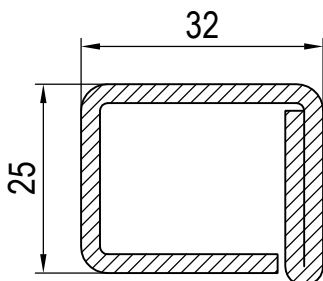

IFI 209010 s=2.5mm 4.0cm⁴
Reinforcements

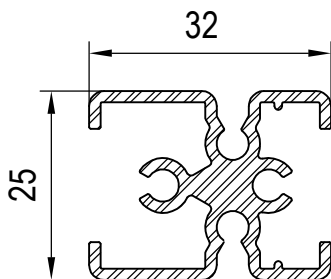

IFI 209015 s=1.5mm 0.5cm⁴
Reinforcements
aluminium

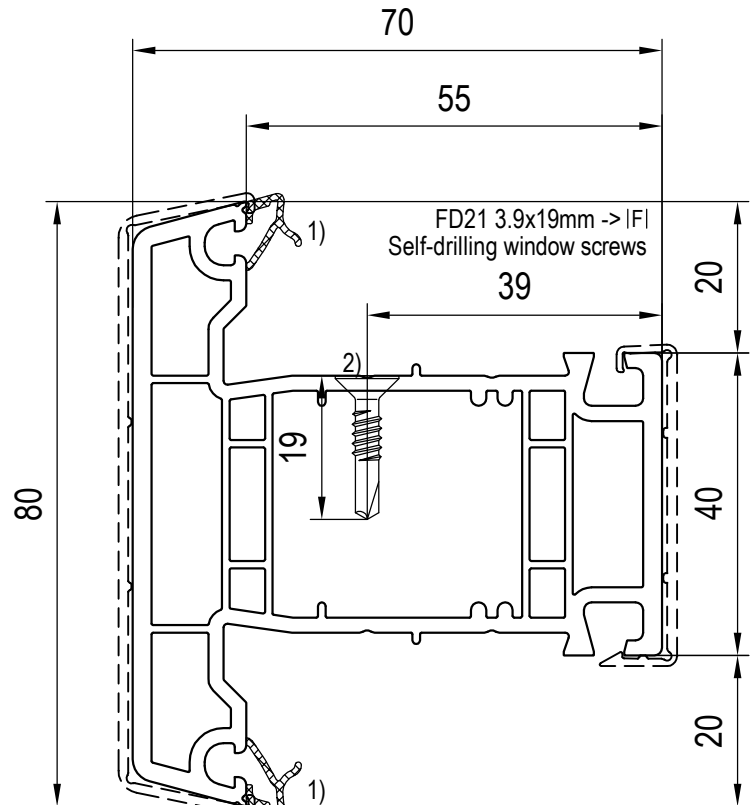

IPI 209358 **aluskin**
IPI 209453 **aluskin**
Aluminium shells

2) Seal the screw heads in the bottom horizontal rebate.
1) Pre-inserted gasket(s): Please refer to valid price list.

mullion - meneau - montante - poste - Pfosten
transom - traverse - travesaño - Sprosse

scale 1:2, 1:1

02_D_01_4IDc*

en May be subject to change
and errors excepted!

Classic-line (CL)

Main Profiles: Mullions / Transoms
Mullions/Transoms 80mm: 100x58

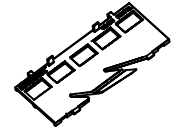

IA 602013
Spacer

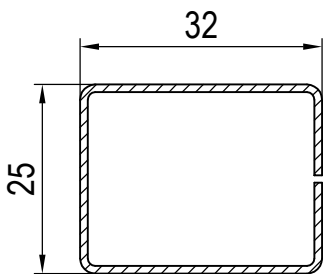
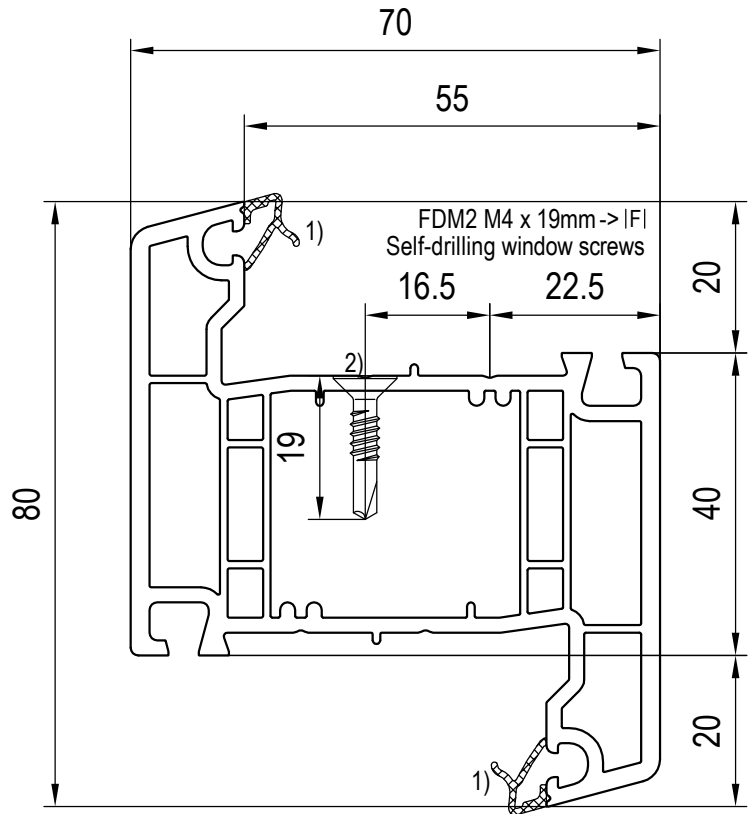

IFI 209003 s=1.5mm 1.6cm⁴
Reinforcements

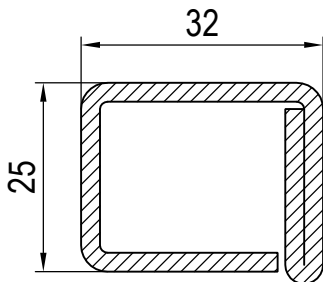

IFI 209010 s=2.5mm 4.0cm⁴
Reinforcements

- 2) Seal the screw heads in the bottom horizontal rebate.
1) Pre-inserted gasket(s): Please refer to valid price list.

Z-mullion - meneau "Z" - montante "Z" - poste en "Z" - Z-Pfosten
Z-transom - traverse "Z" - traverso "Z" - travesaño en "Z" - Z-Sprosse

scale 1:1, 1:2

02_D_01_4IDc*

en May be subject to change and errors excepted!

Classic-line (CL)

Main Profiles: Mullions / Transoms
Z-mullion, 80mm: 100x59

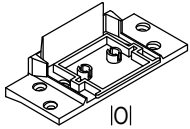

IOI 677133
 ØI 647136
 DI Connector
 ØI Connector without sticks

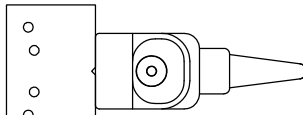

IOI 640901
 Mounting accessories

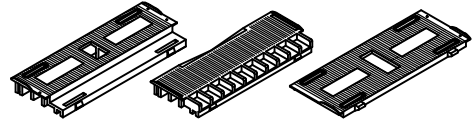

IAI 640311 IAI 640320 IAI 640301
 Spacer
 t = 5mm t = 5mm t = 0mm
 10-25mm 10-41mm 10-41mm Glazing

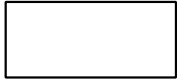

~45x20x1000 mm
 ØI 640046



IXI 459951 bl -> IPI or IXI 449986 bl -> IPI
 -> Glazing Gasket -> Glazing Gasket



IXI 429320 bl -> IPI or IXI 449346 bl -> IPI
 -> Stop Gasket -> Stop Gasket

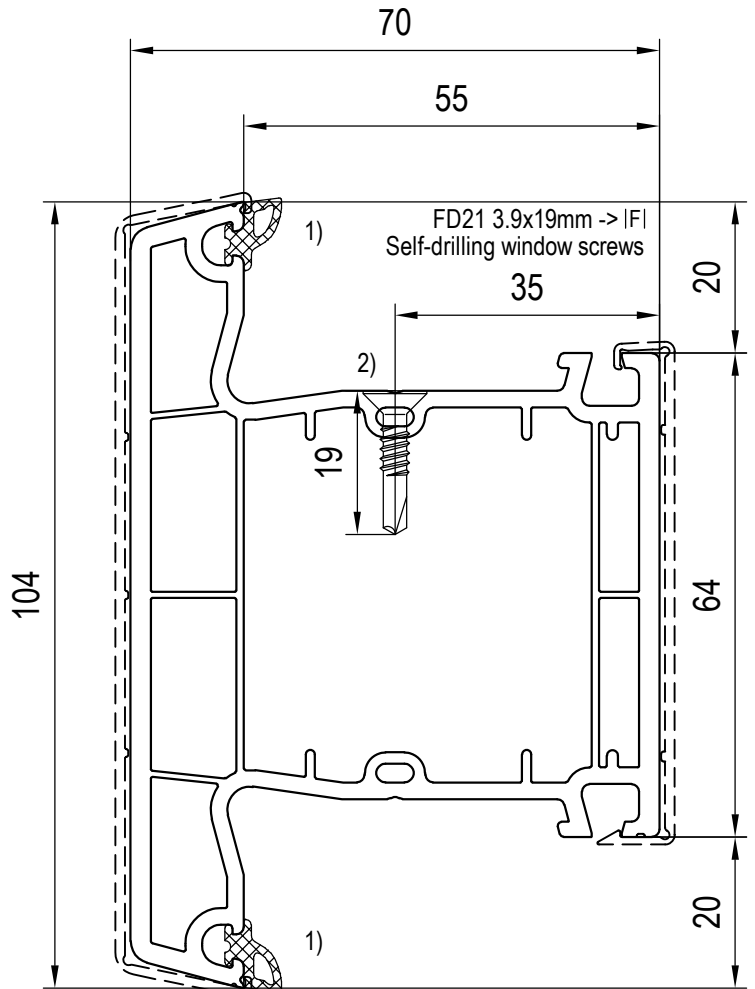

IPI 249343 **aluskin**
 IPI 249443 **aluskin**
 Aluminium shells

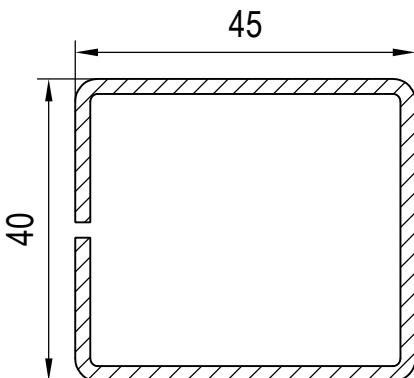

IFI 249034 s=1.25mm 6.1cm4
 IFI 249035 s=2.0mm 9.2cm4
 Reinforcements

For door sashes with letter slots (letter box)
 2) Seal the screw heads in the bottom horizontal rebate.
 1) Pre-inserted gasket(s): Please refer to valid price list.

mullion - meneau - montante - poste - Pfosten
 transom - traverse - traveso - travesaño - Sprosse

scale 1:2, 1:1

02_D_01_4IDc*

en May be subject to change and errors excepted!

Classic-line (CL)

Main Profiles: Mullions / Transoms
 Mullions/Transoms 104mm: 140x45

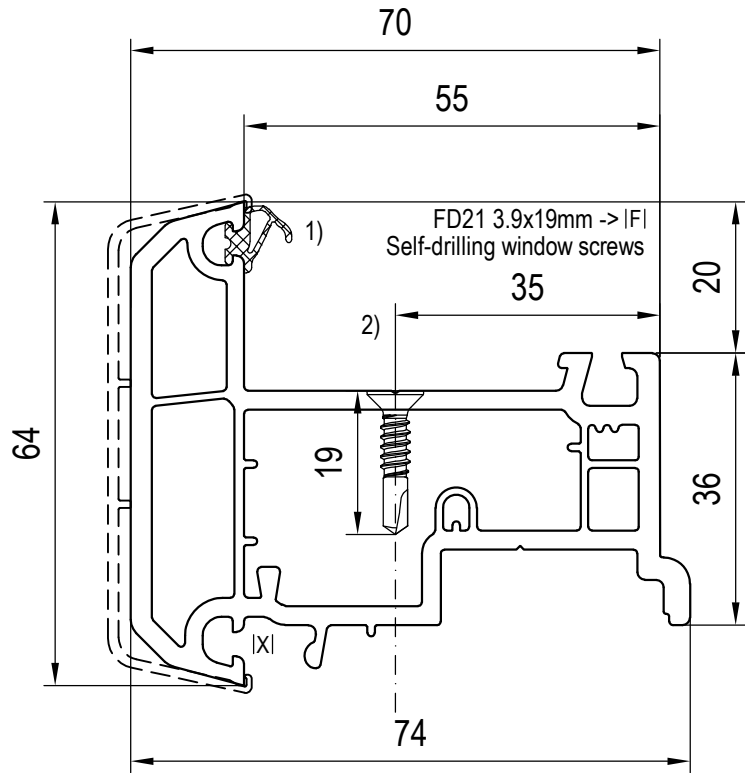

IPI 249366 **aluskin**
Aluminium shells

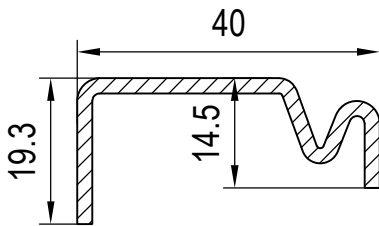

IFI 259094 s=2.0mm 3.1/0.4cm4
Reinforcements



IXI 447340, 449340
Gaskets

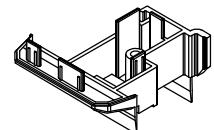

ICI 640067
End caps

- 2) Screw false mullion directly to the sash profile (screw through).
- 1) Pre-inserted gasket(s): Please refer to valid price list.

false mullion - battement - scambio battuta - batiente - Stulp

scale 1:1

02_E_01_4IDc*

en May be subject to change and errors excepted!

Soft-line (SL)

Main Profiles: False Mullion Sashes / False Mullion Profiles

False mullion 64mm: 140x67

Overview: Cross Sections - Examples (open-out / fixed glazing)

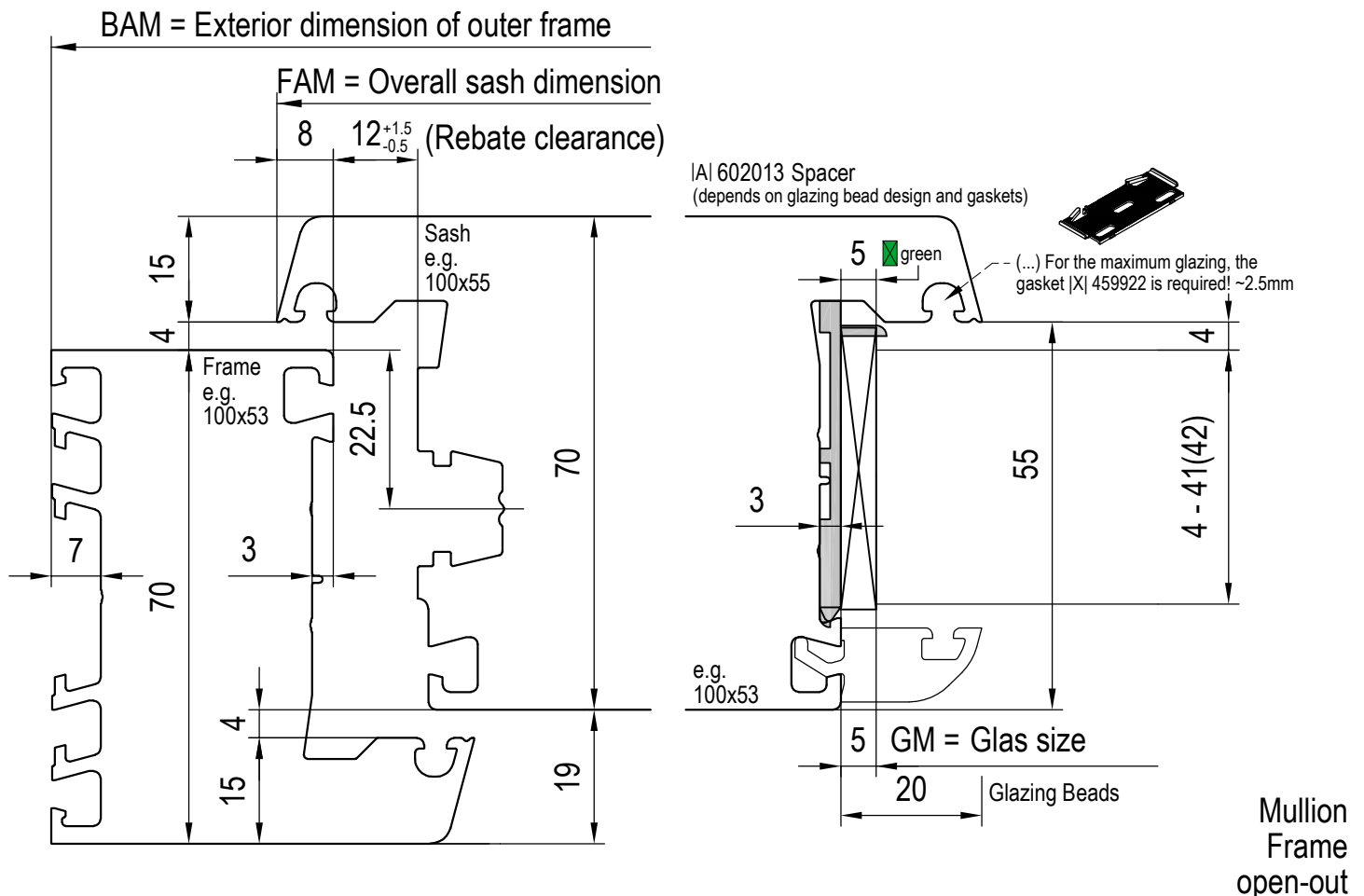
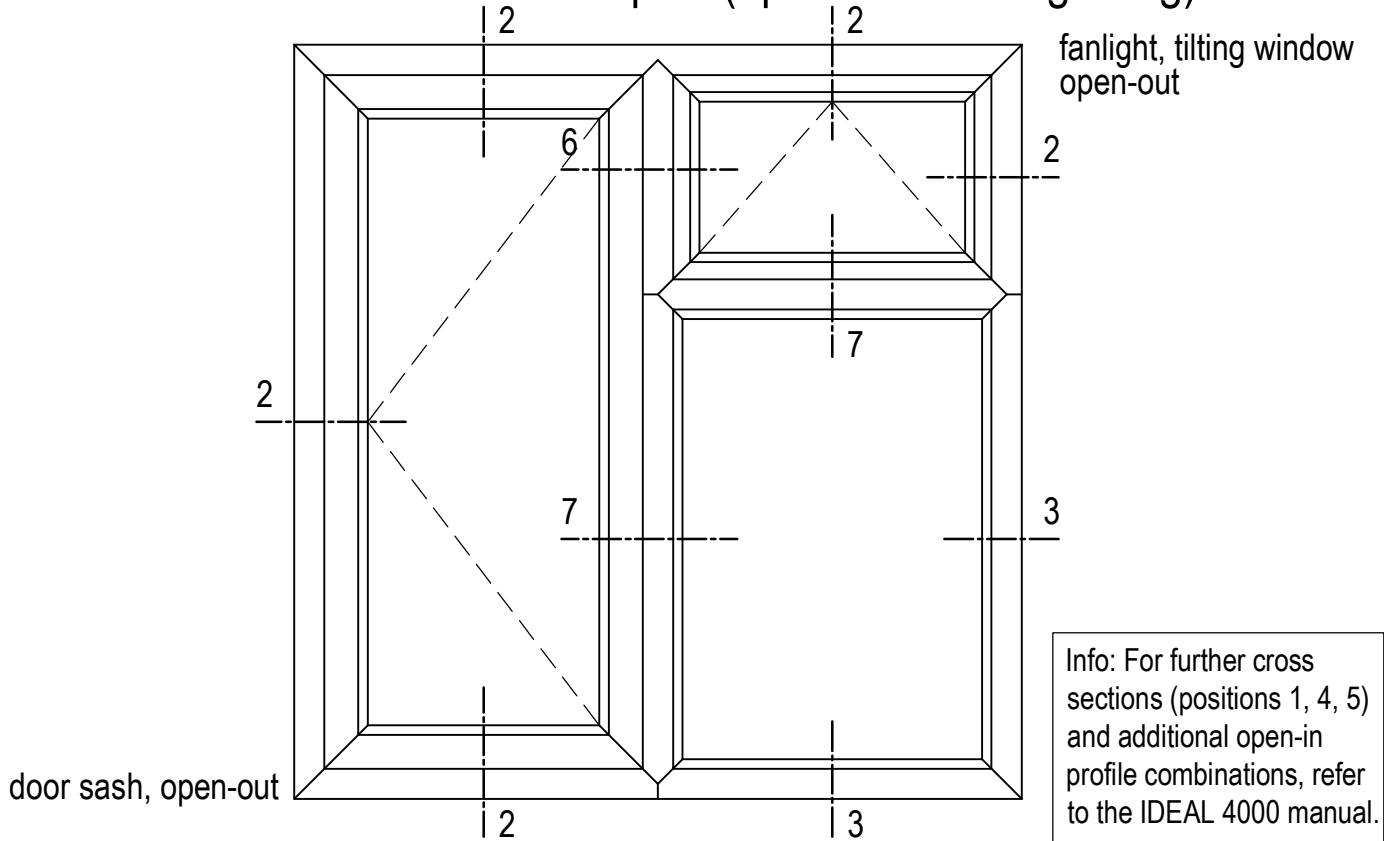

aluplast ≥ 24mm Glazing thickness
Bonding of pane

- Ⓜ |JI 642262 Bonding of pane
- Ⓜ |JI 642261/646265 Bonding of pane
- Ⓜ |JI 642263/646266 Bonding of pane
(depends on glazing bead design and gaskets)

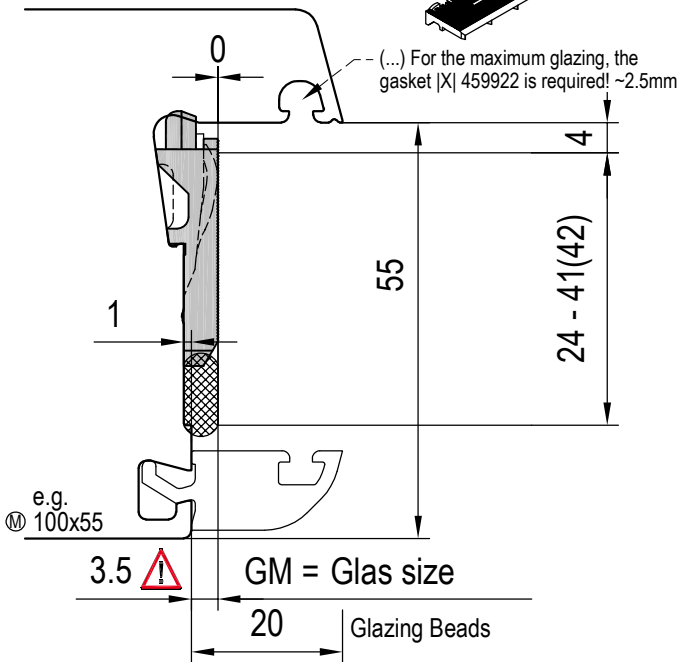
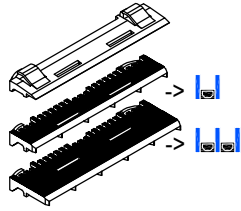

- Ⓜ |AI 655251 Spacer
(depends on glazing bead design and gaskets)

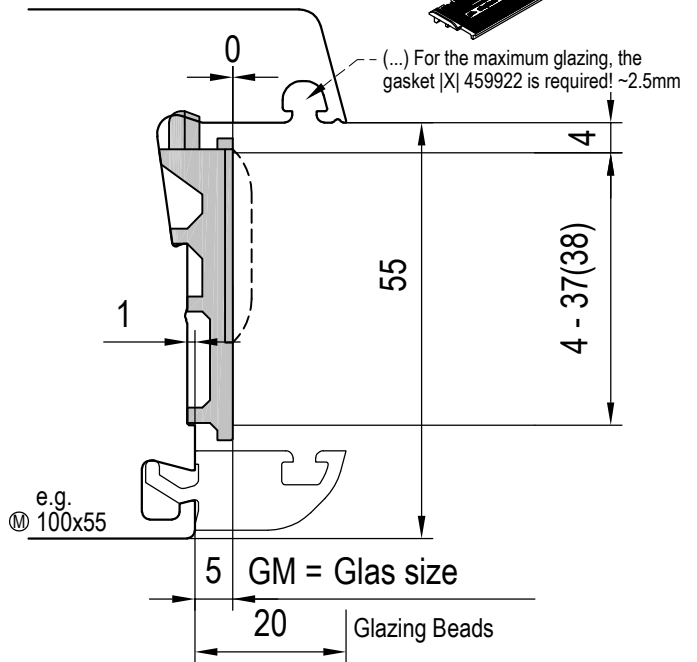
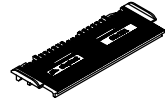

- Ⓜ |AI 650250 Spacer
(depends on glazing bead design and gaskets)

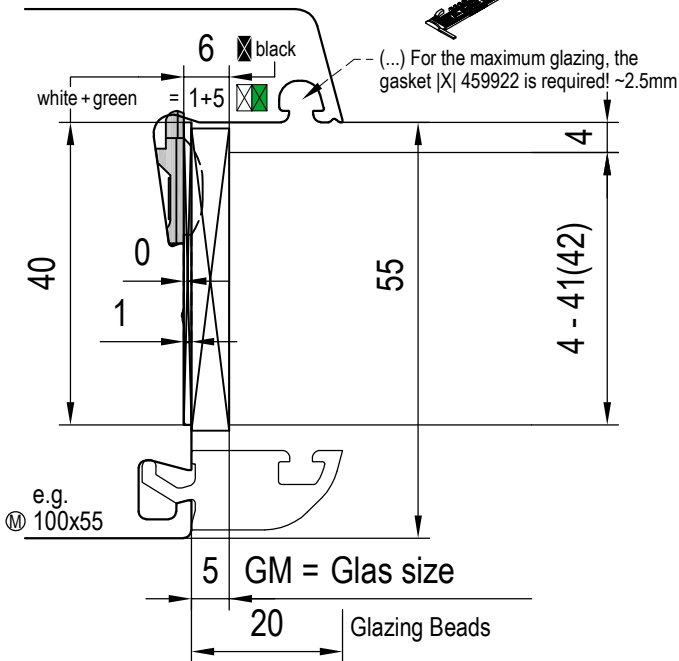

- Ⓜ |AI 650252 Spacer
(depends on glazing bead design and gaskets)

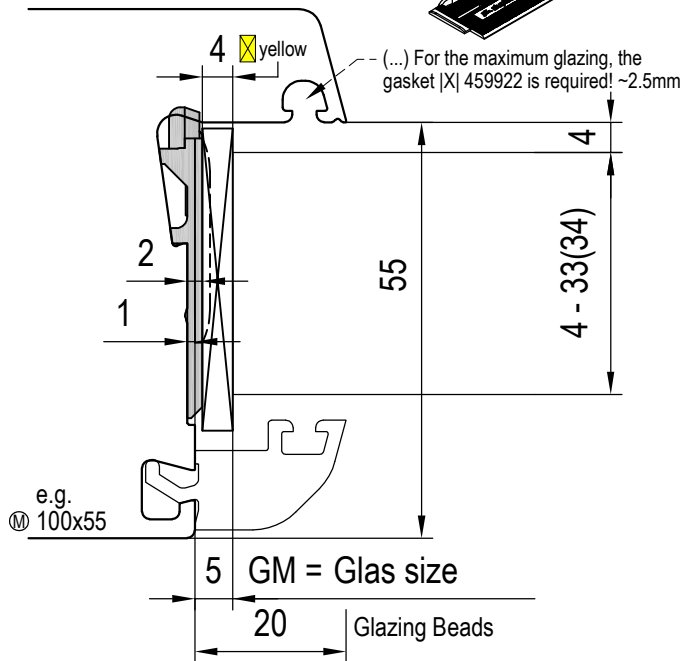
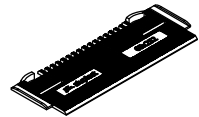

T-Sash
open-out

Scale ~, 1:1

03_A_01_4IDc*

en May be subject to change and errors excepted!

Combinations:

Construction Dimensions
Glazing

 ≥ 24mm Glazing thickness
Bonding of pane

Ⓜ IJI 642262 Bonding of pane
Ⓜ IJI 642261/646265 Bonding of pane
(depends on glazing bead design and gaskets)

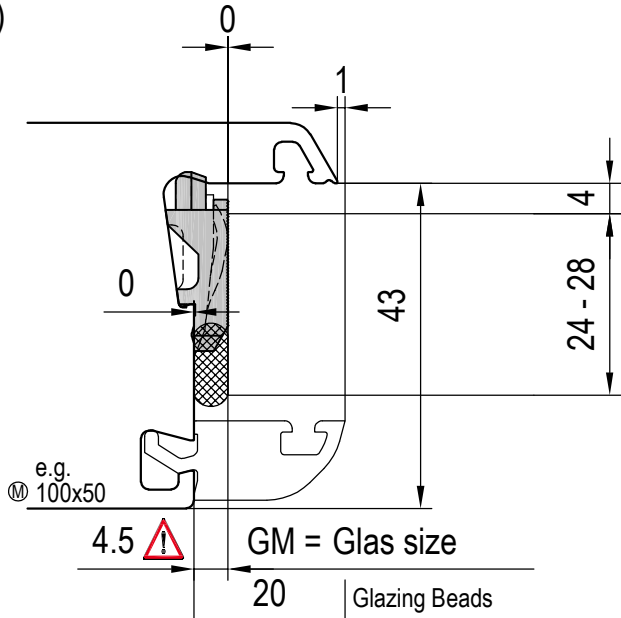
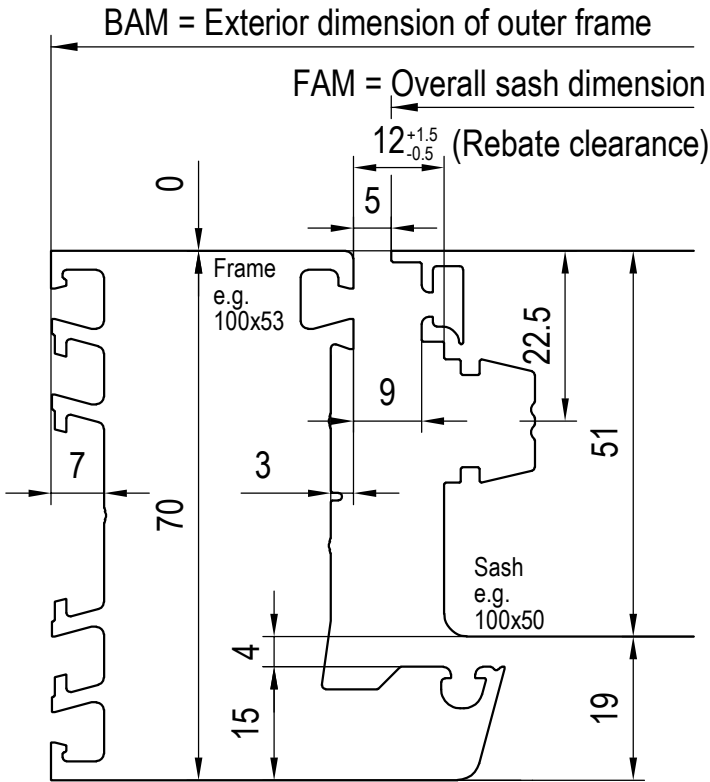
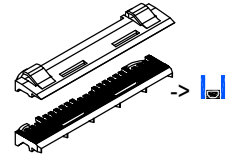

Ⓜ IAI 650250 Spacer
(depends on glazing bead design and gaskets)

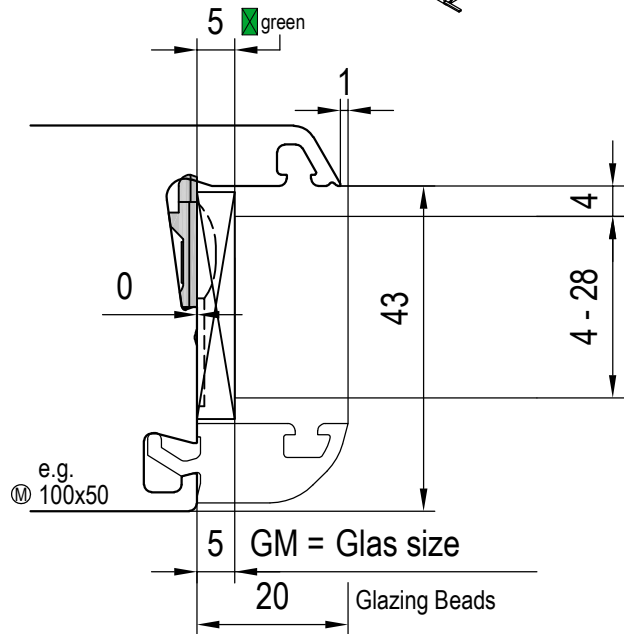

Flush-Sash
open-out

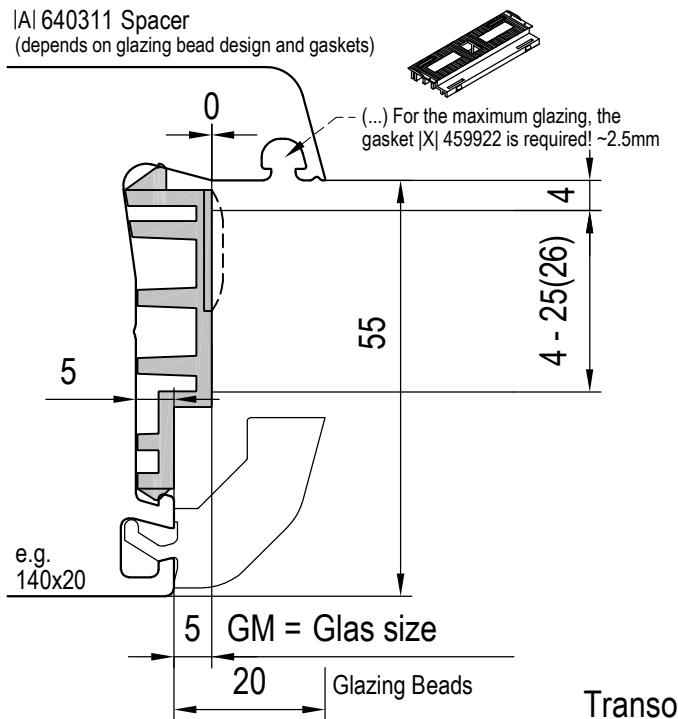
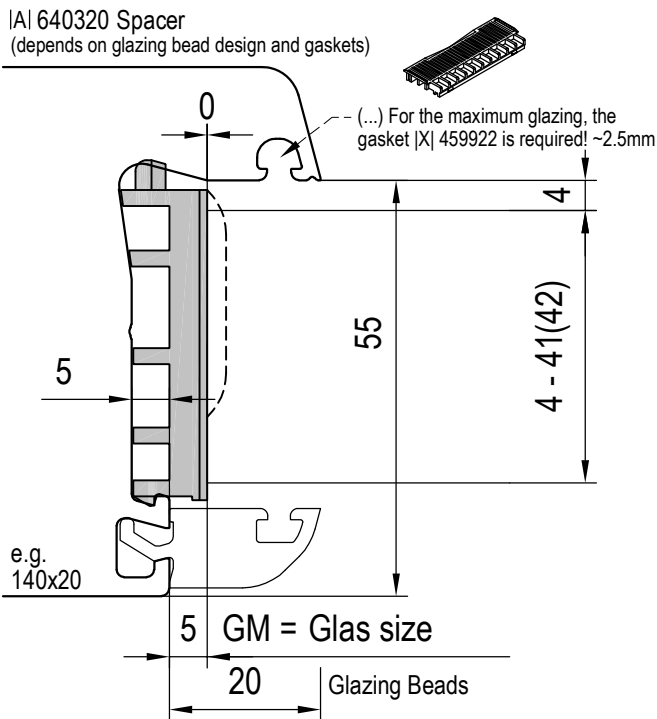
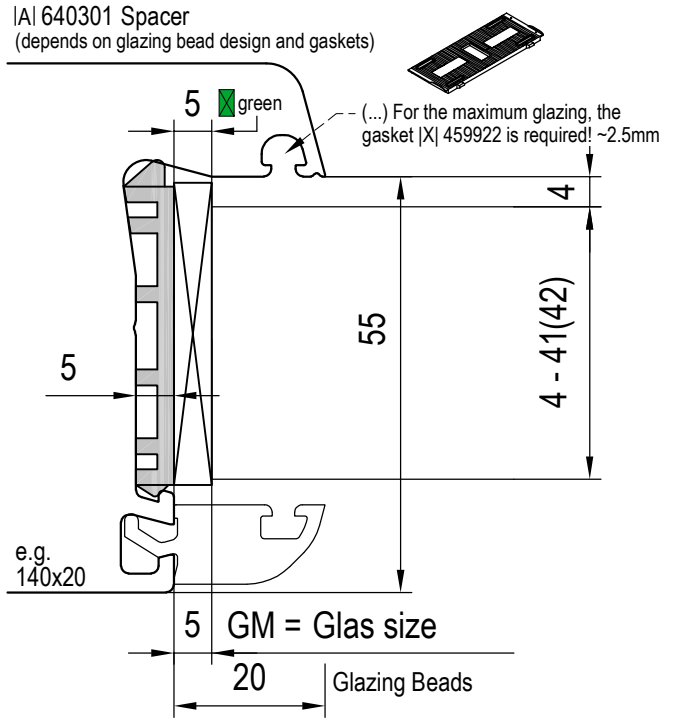
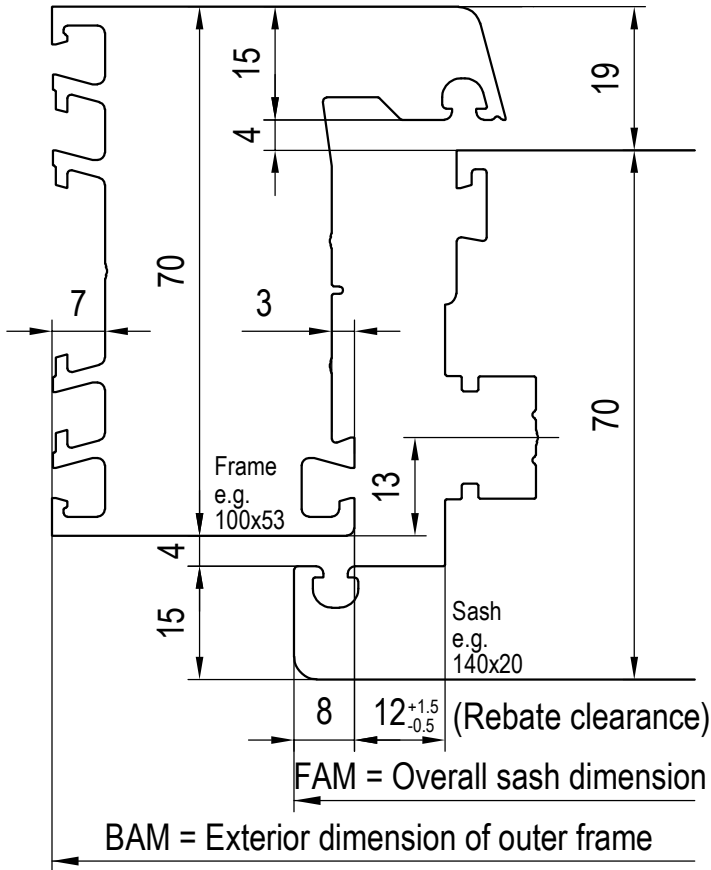

Transoms
Sash
open-in

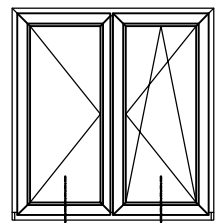
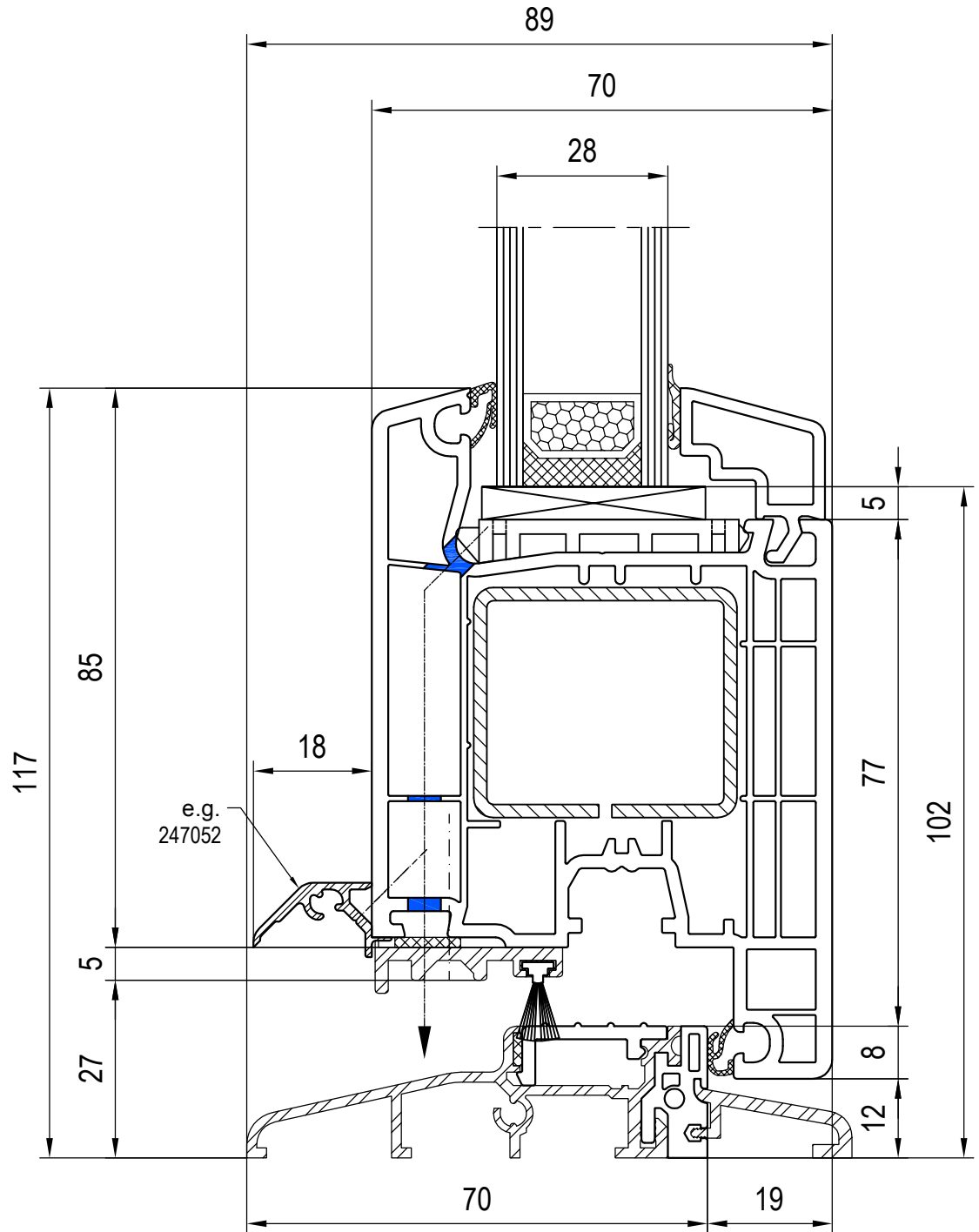



 Seal thresholds laterally with silicone rubber!

scale 1:1
03_C_01_4IDc_casem*
en May be subject to change and errors excepted!

Combinations: Low aluminium threshold
120636/120666 Glazing Bead

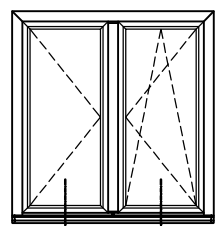
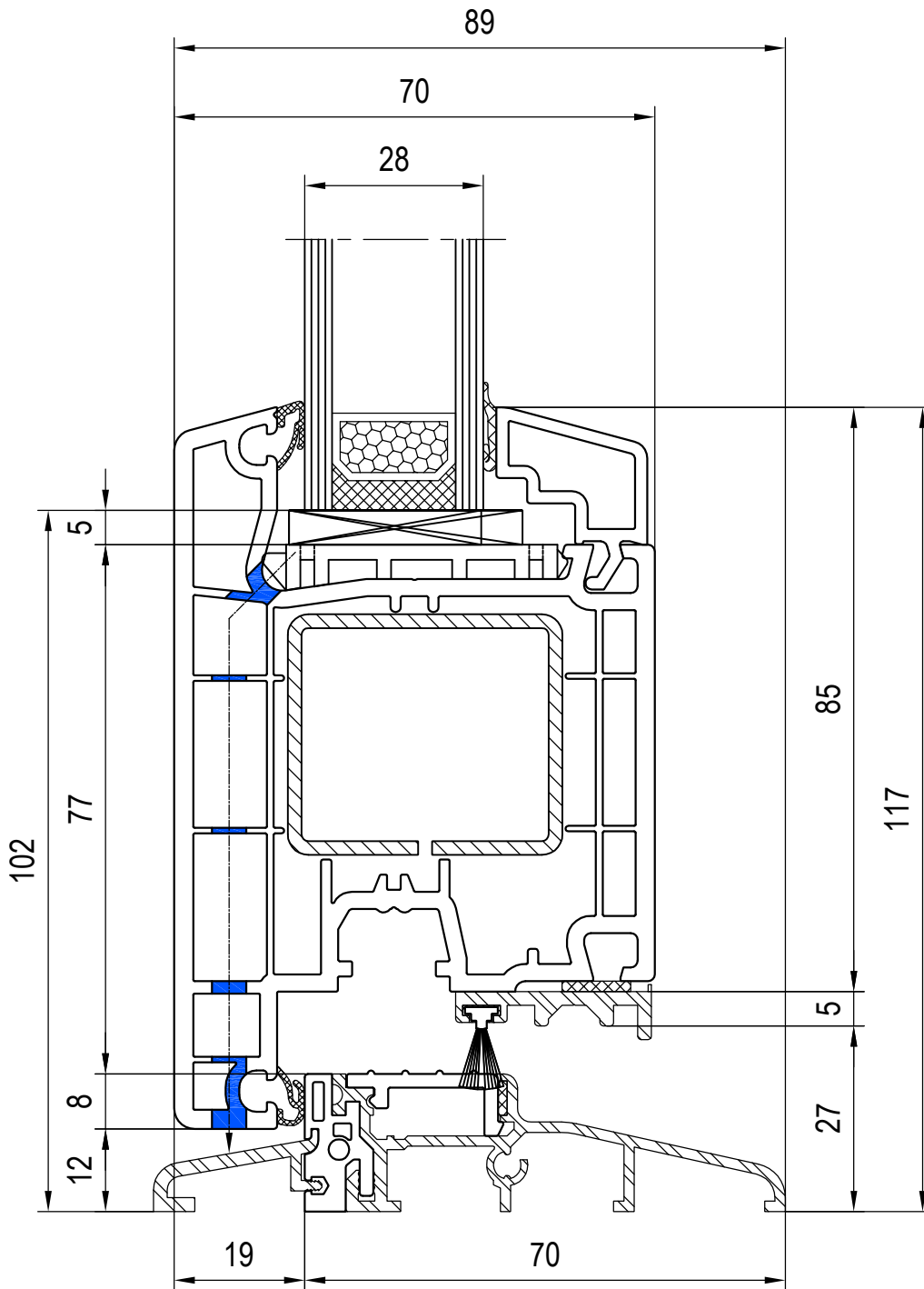
10x103, 20x101, 20x102, 20x104
Sash 140x30



 Seal thresholds laterally with silicone rubber!

1) Required for 120mm frame profile depth

scale 1:1

03_C_01_4IDc_casem*

en May be subject to change and errors excepted!

Combinations: Low aluminium threshold
120636/120666 Glazing Bead

10x103, 20x101, 20x102, 20x104
Sash 140x31

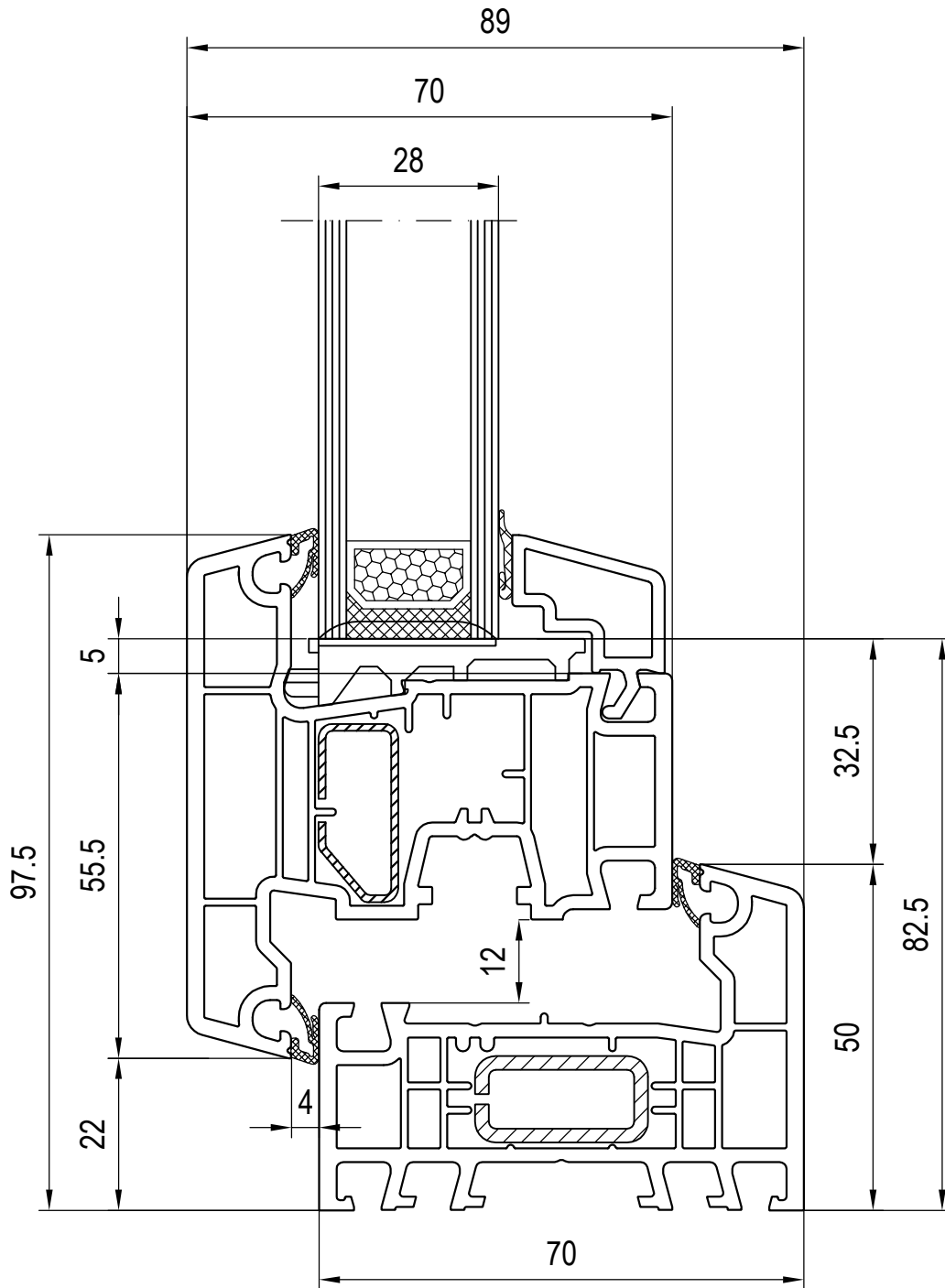

2

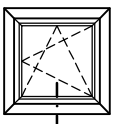

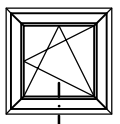
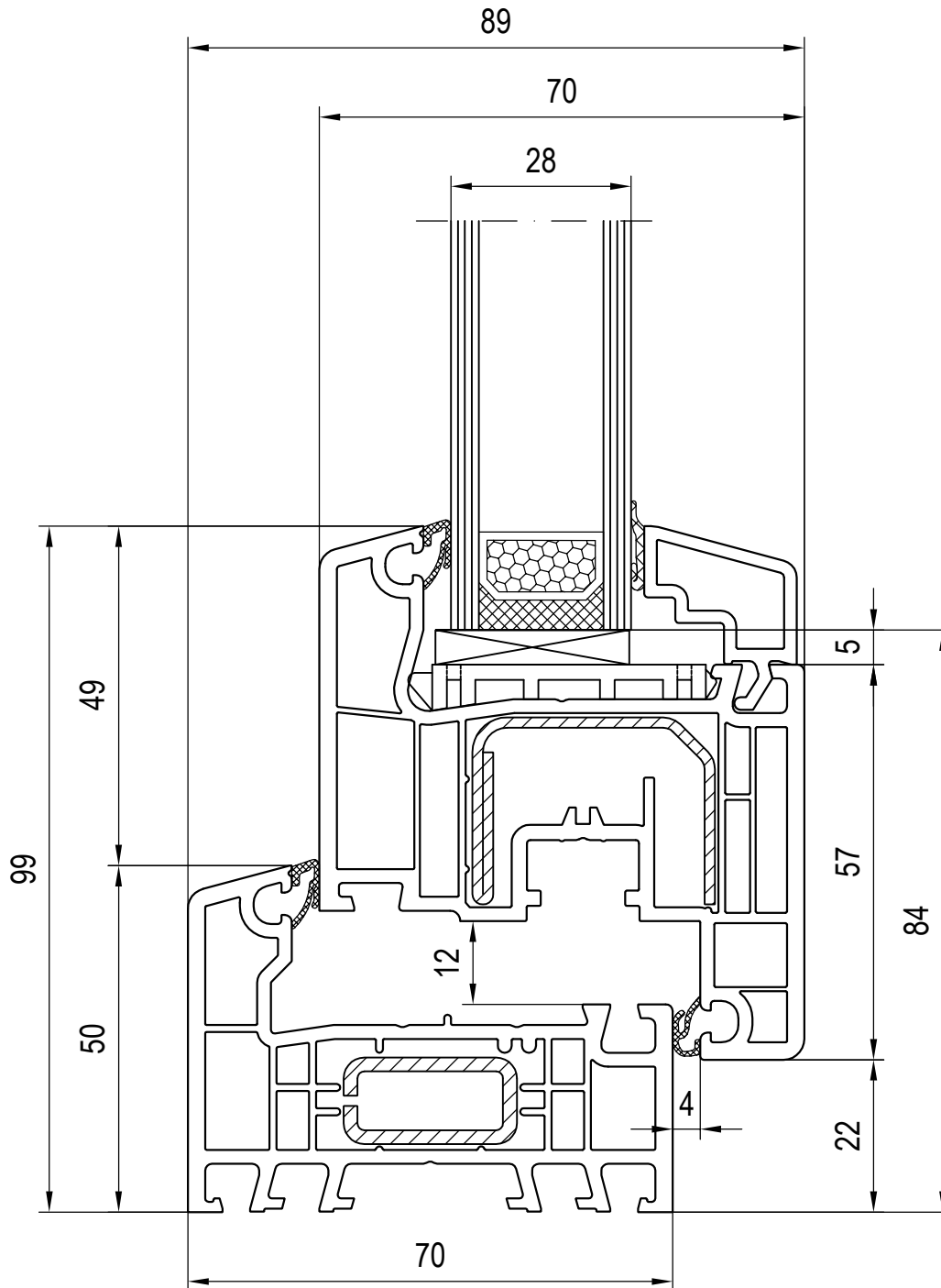

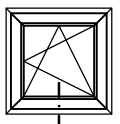
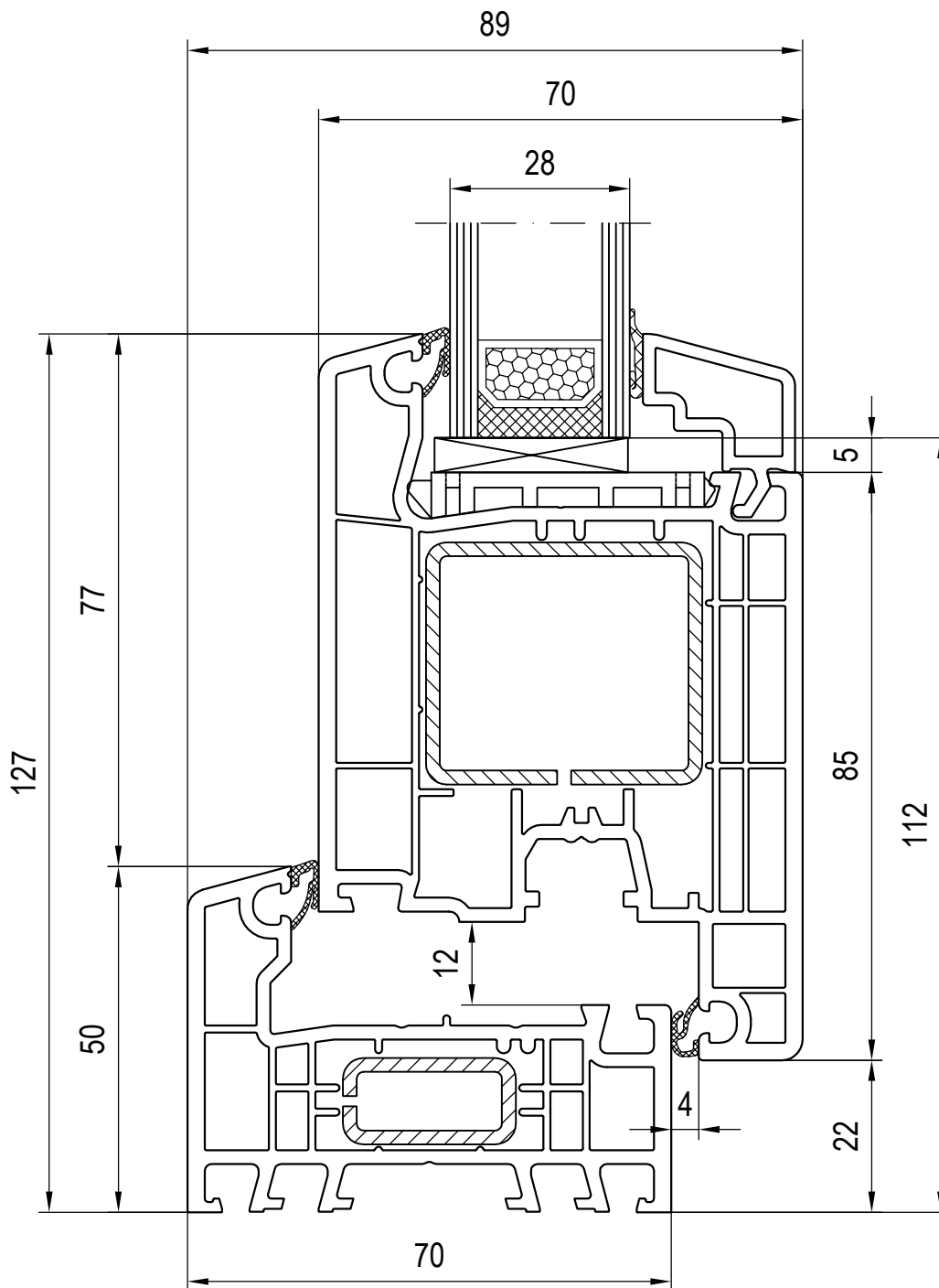

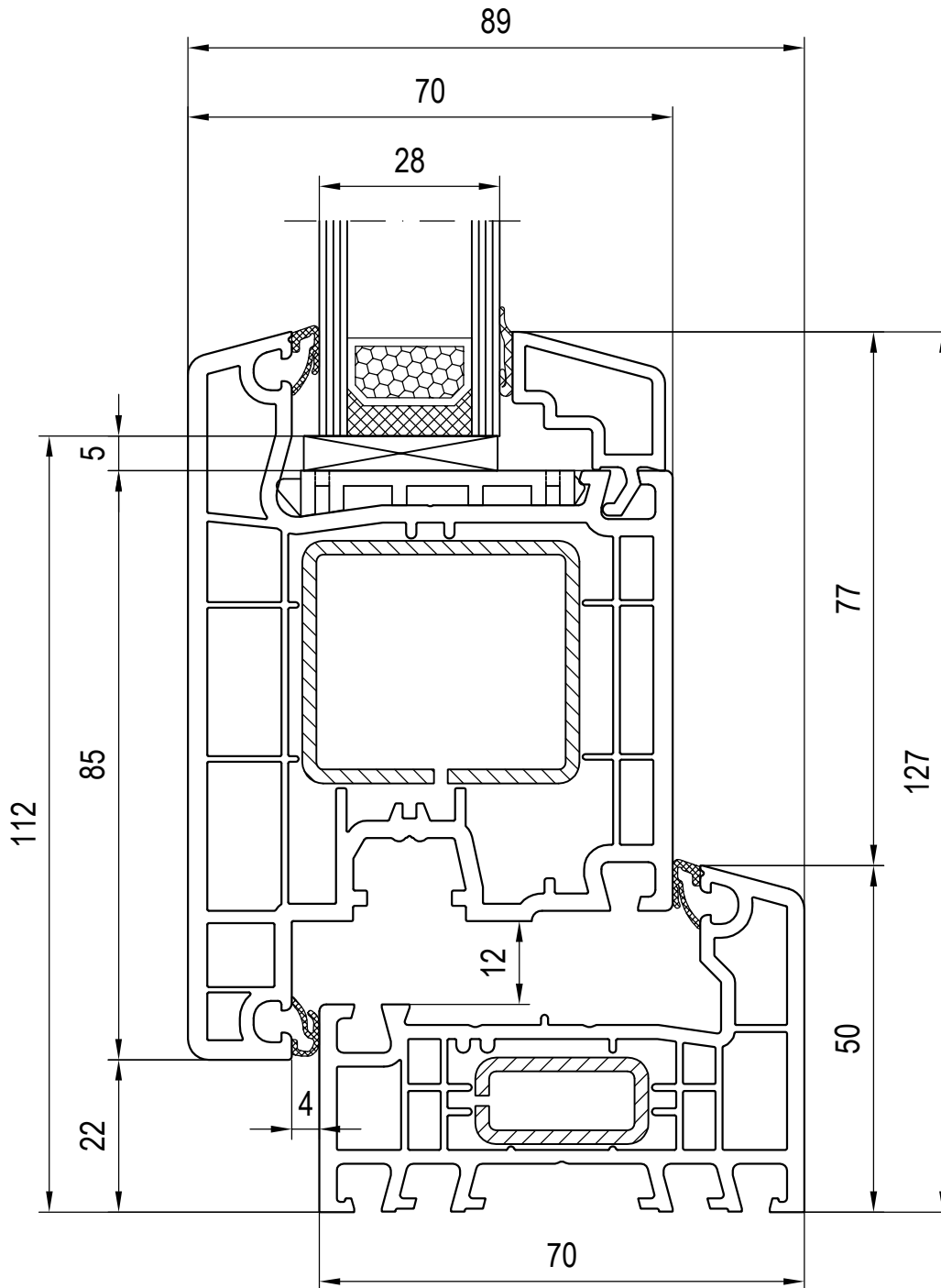

2

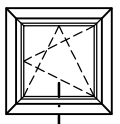

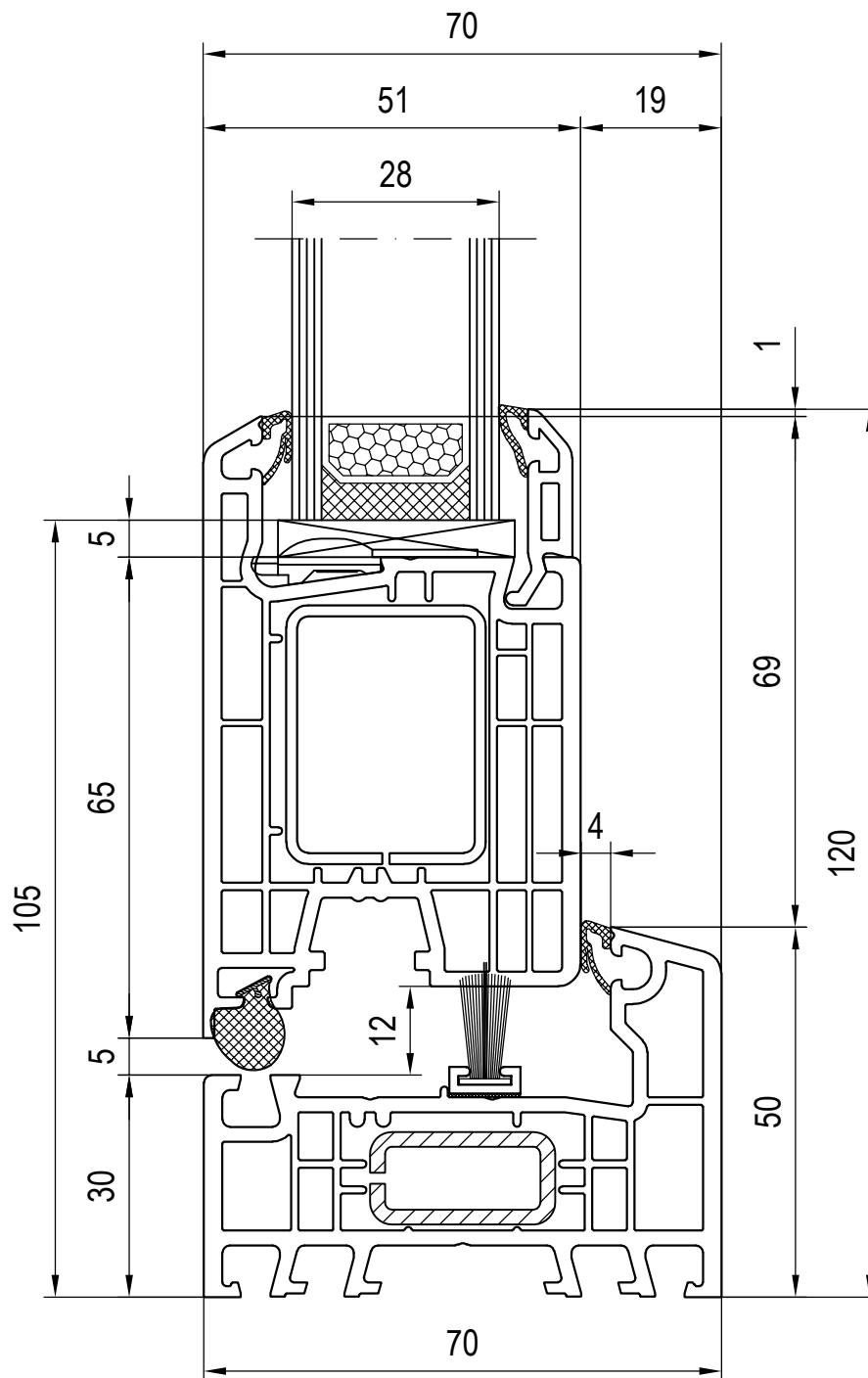

2

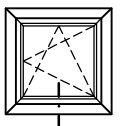

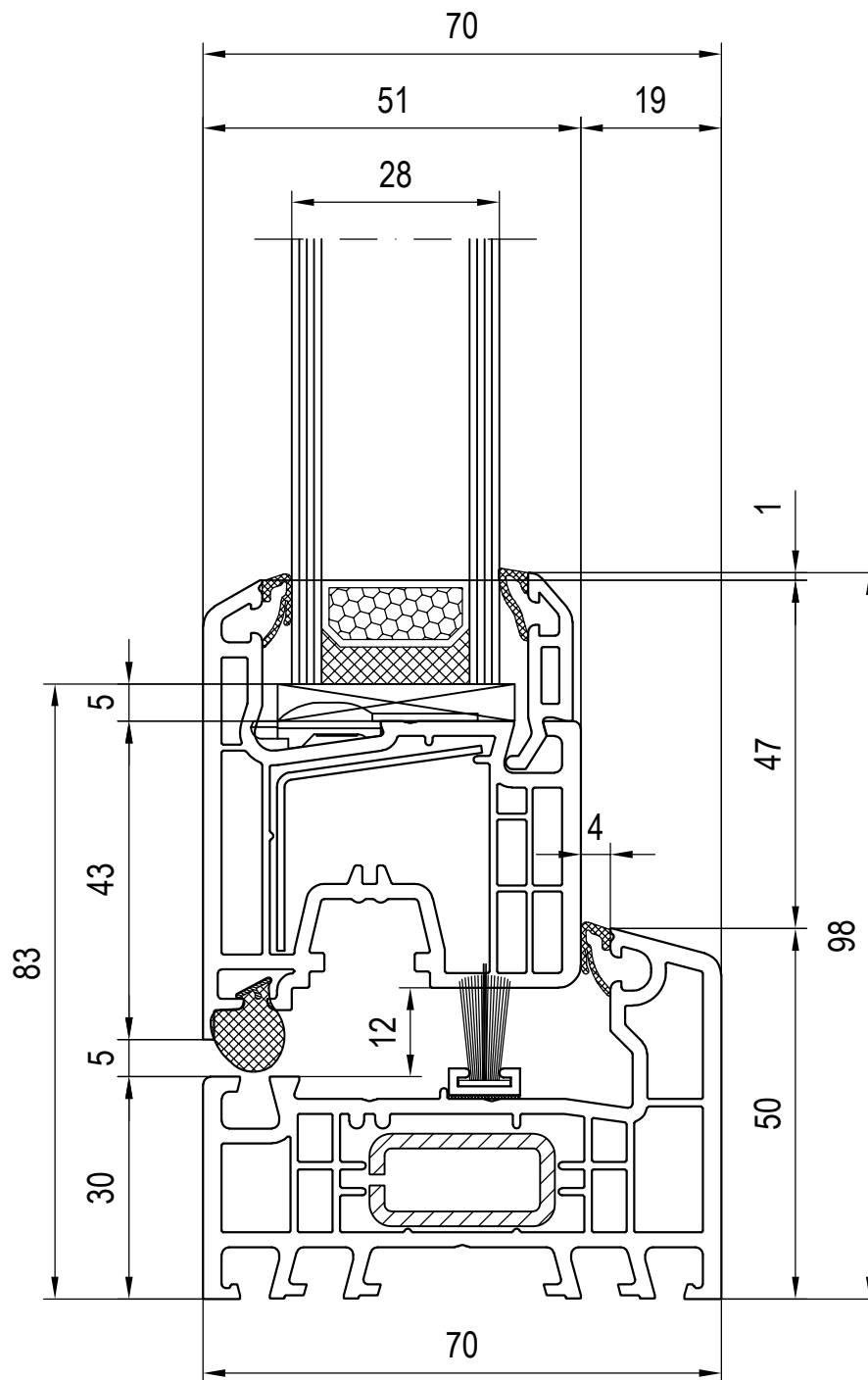

2

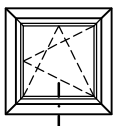

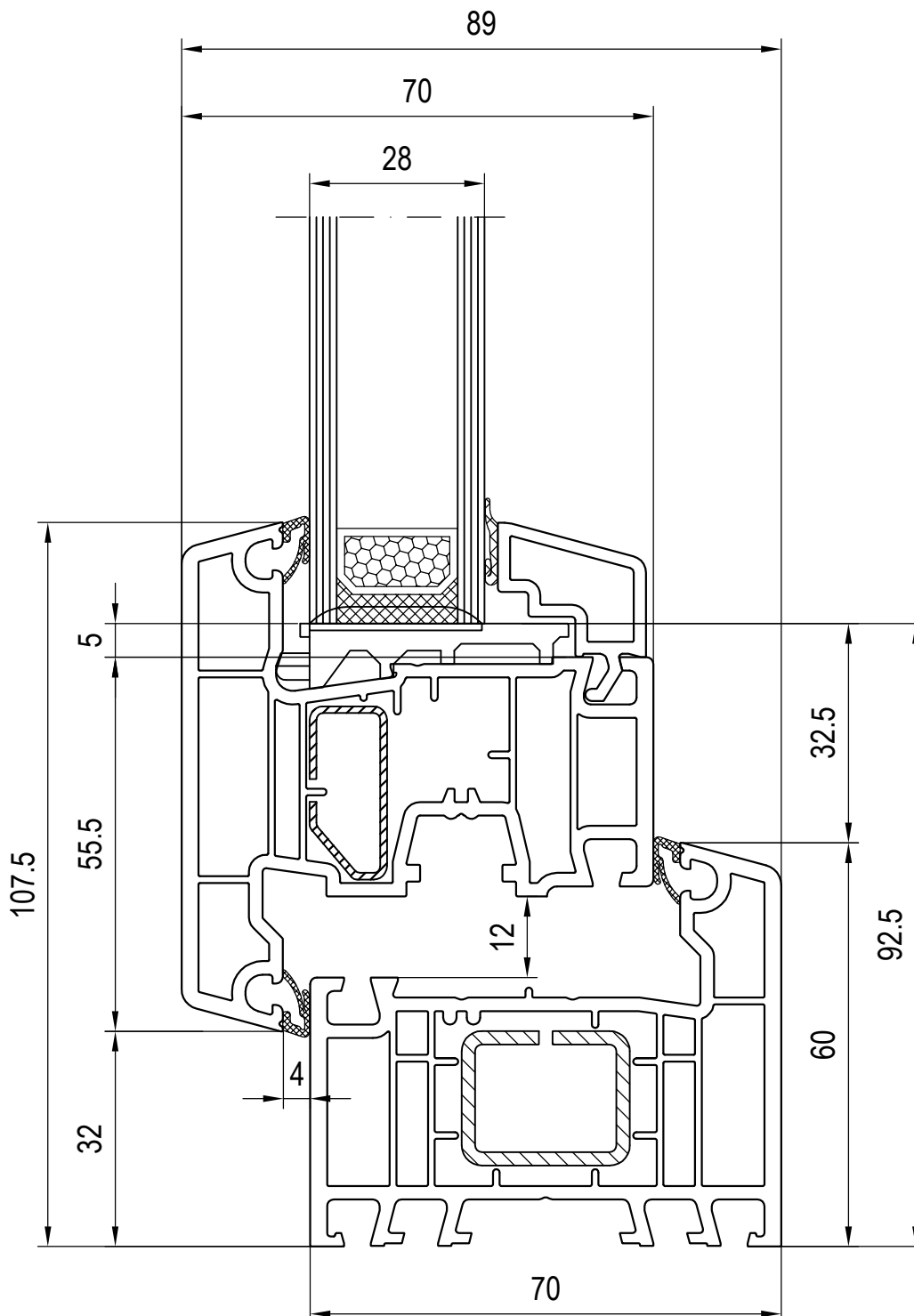

2

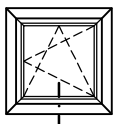

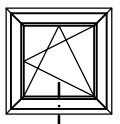
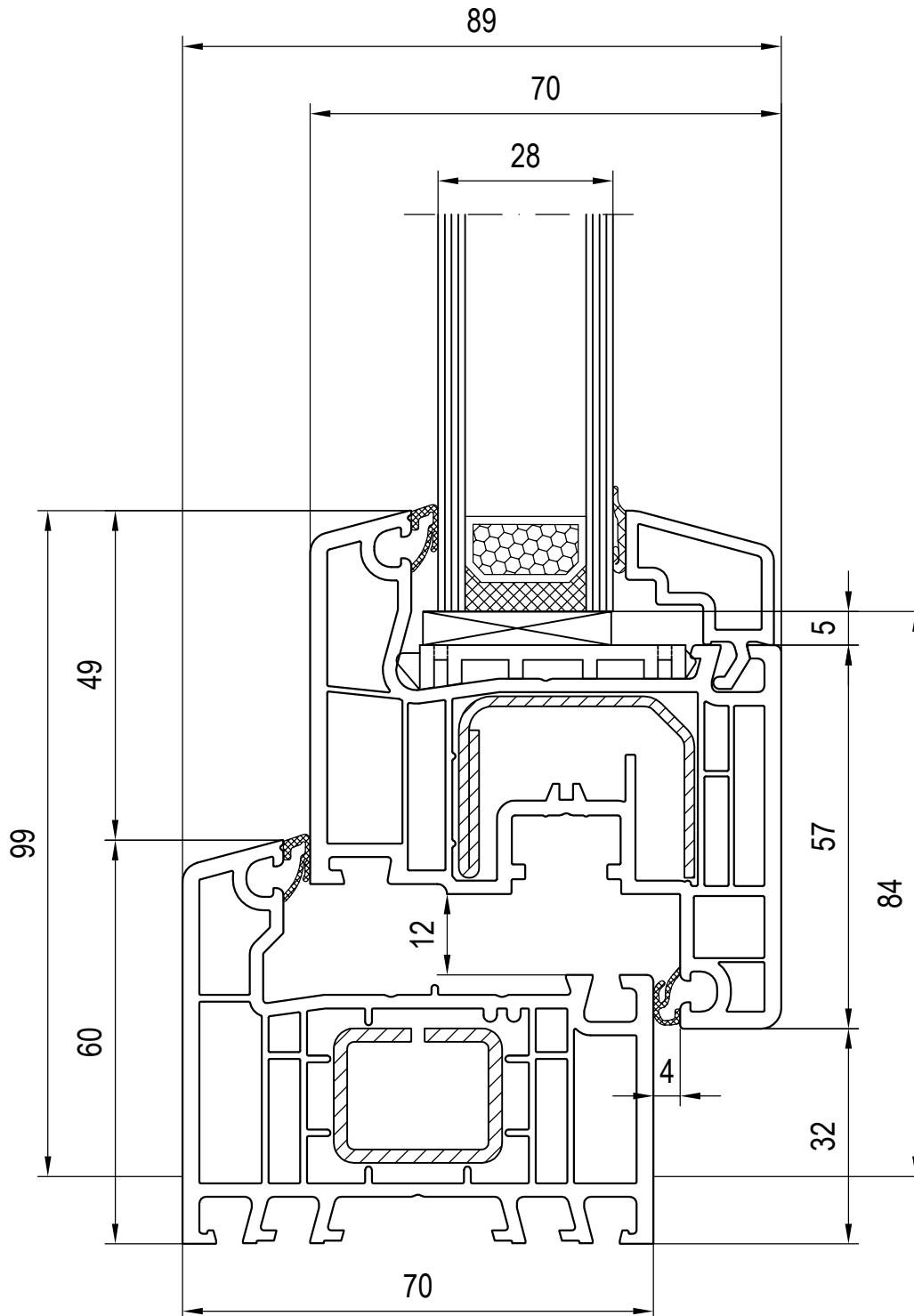

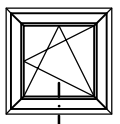
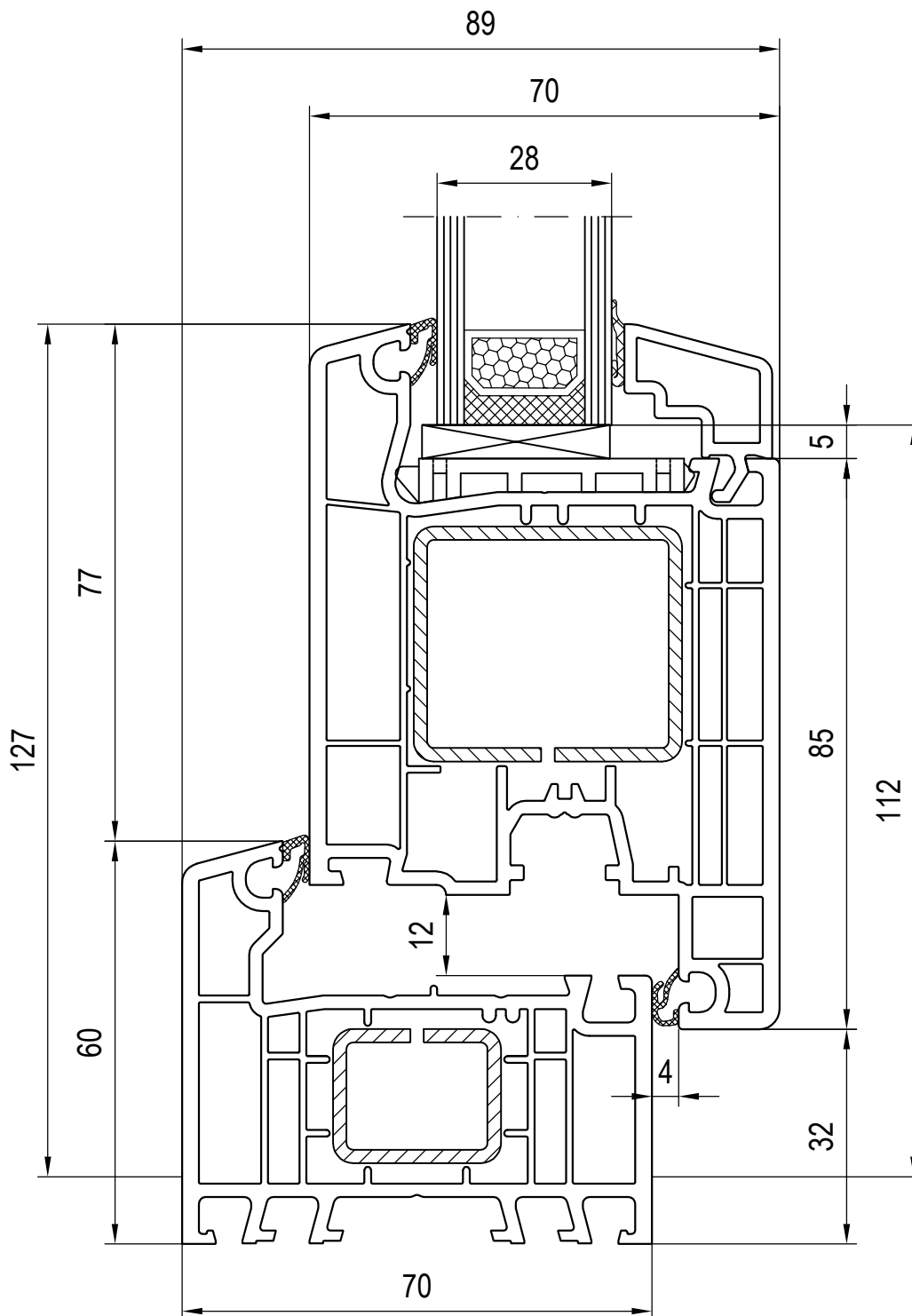

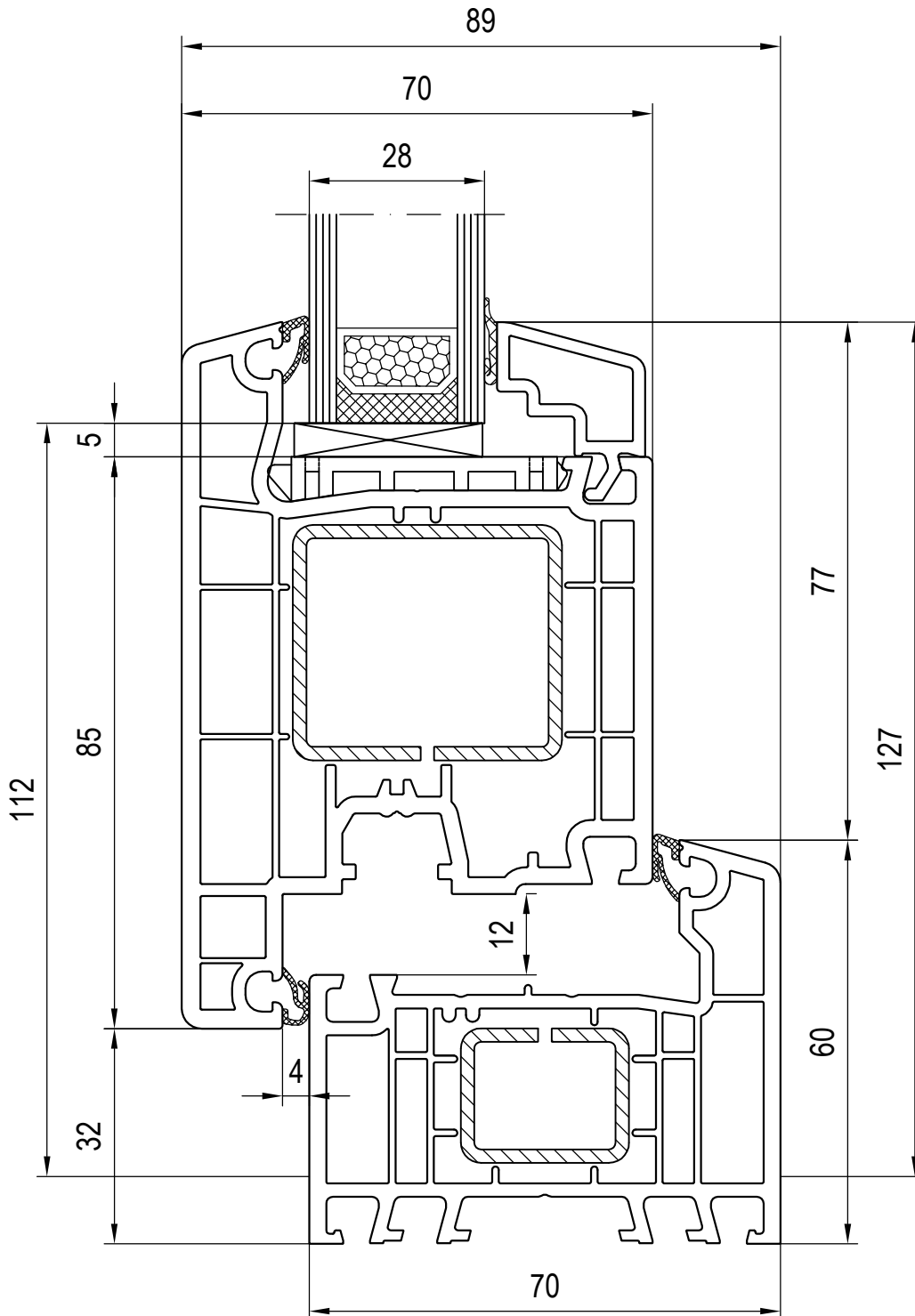

2

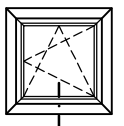

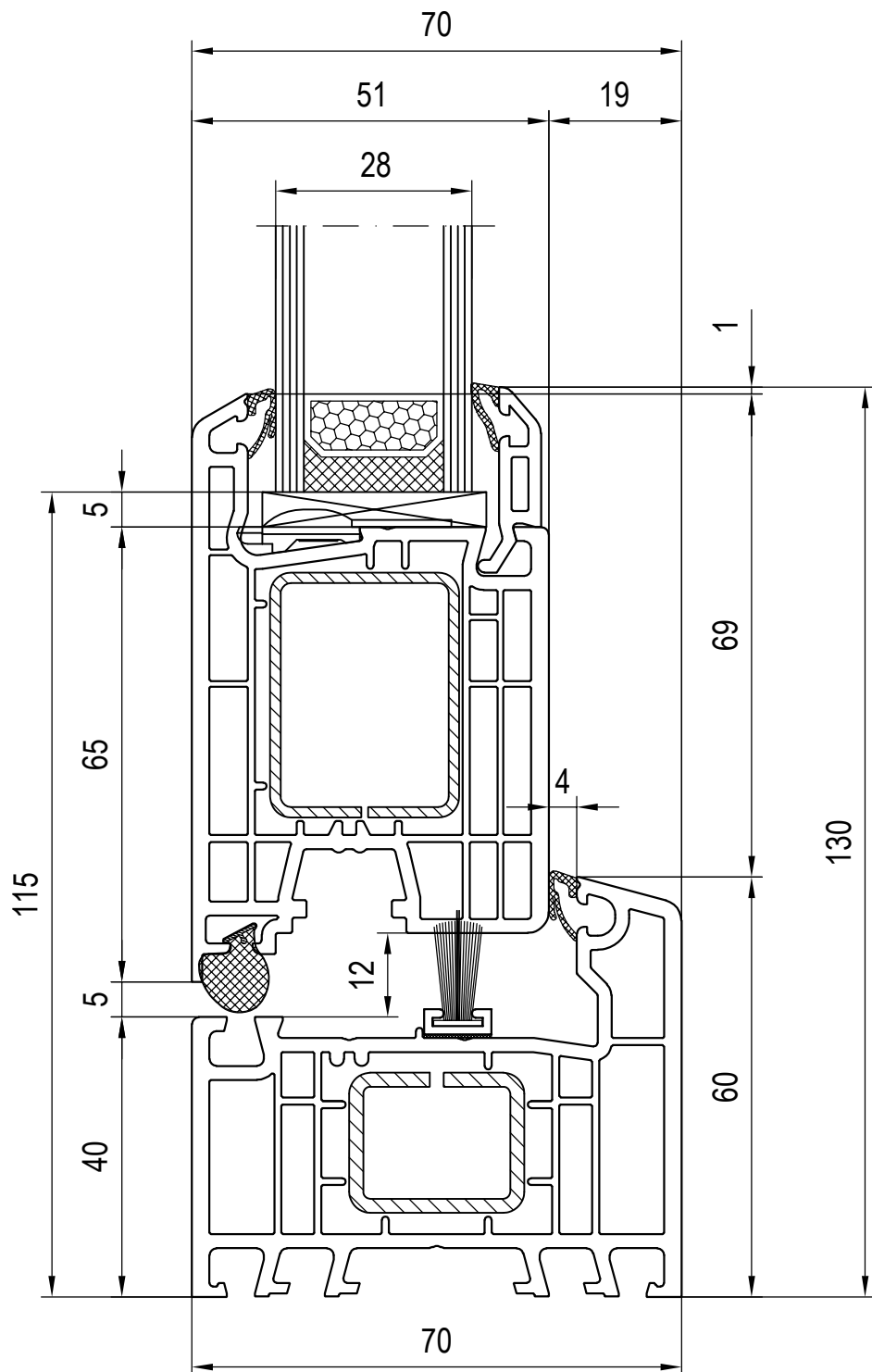

2

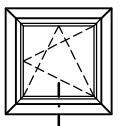

scale 1:1

03_D_01_4IDc_casem*

en May be subject to change and errors excepted!

Combinations: Frame - Sash

140631/140661 Glazing Bead

Frame 100x53

Sash 100x50

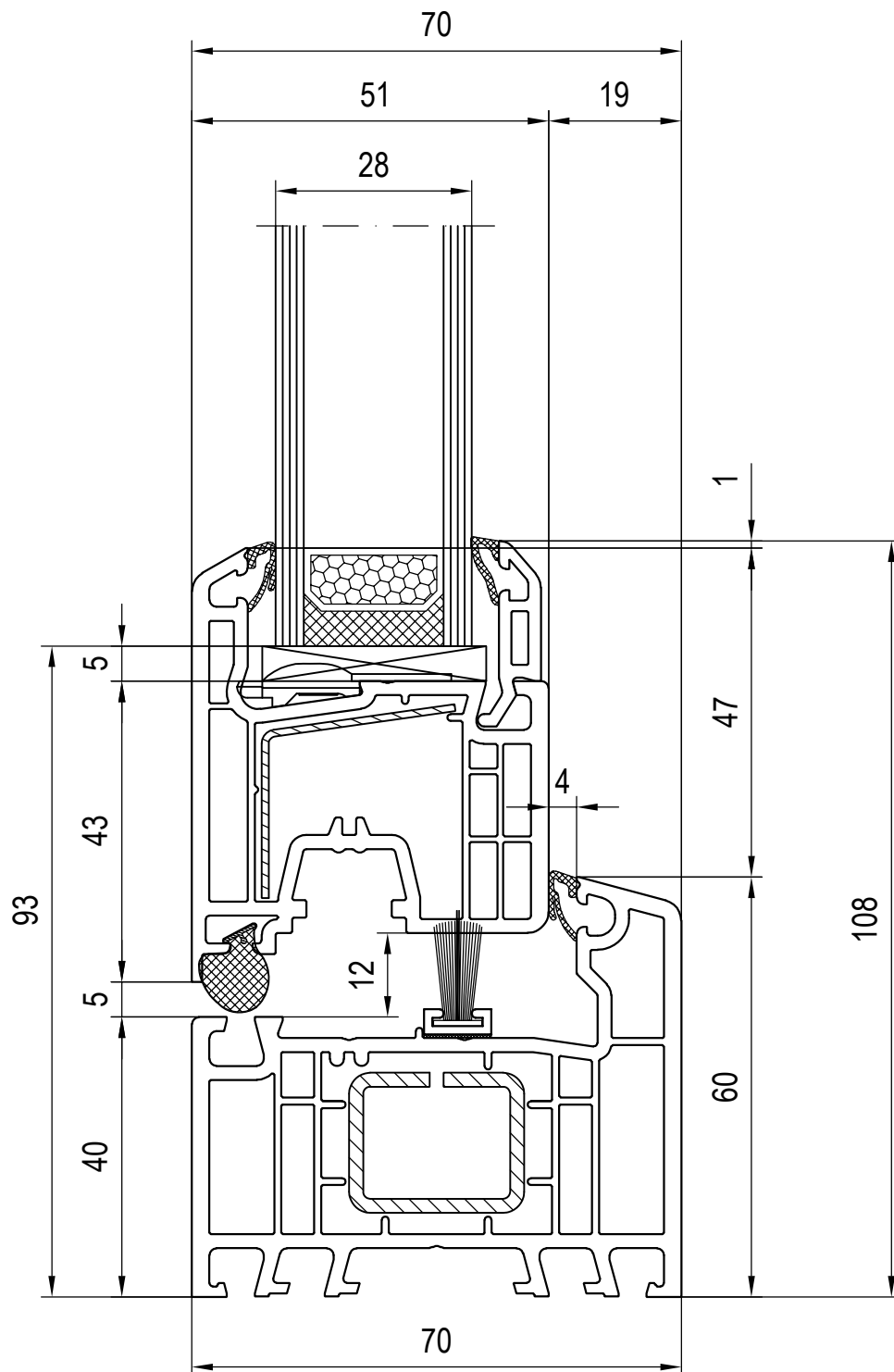

2

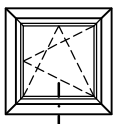

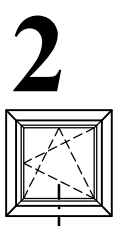
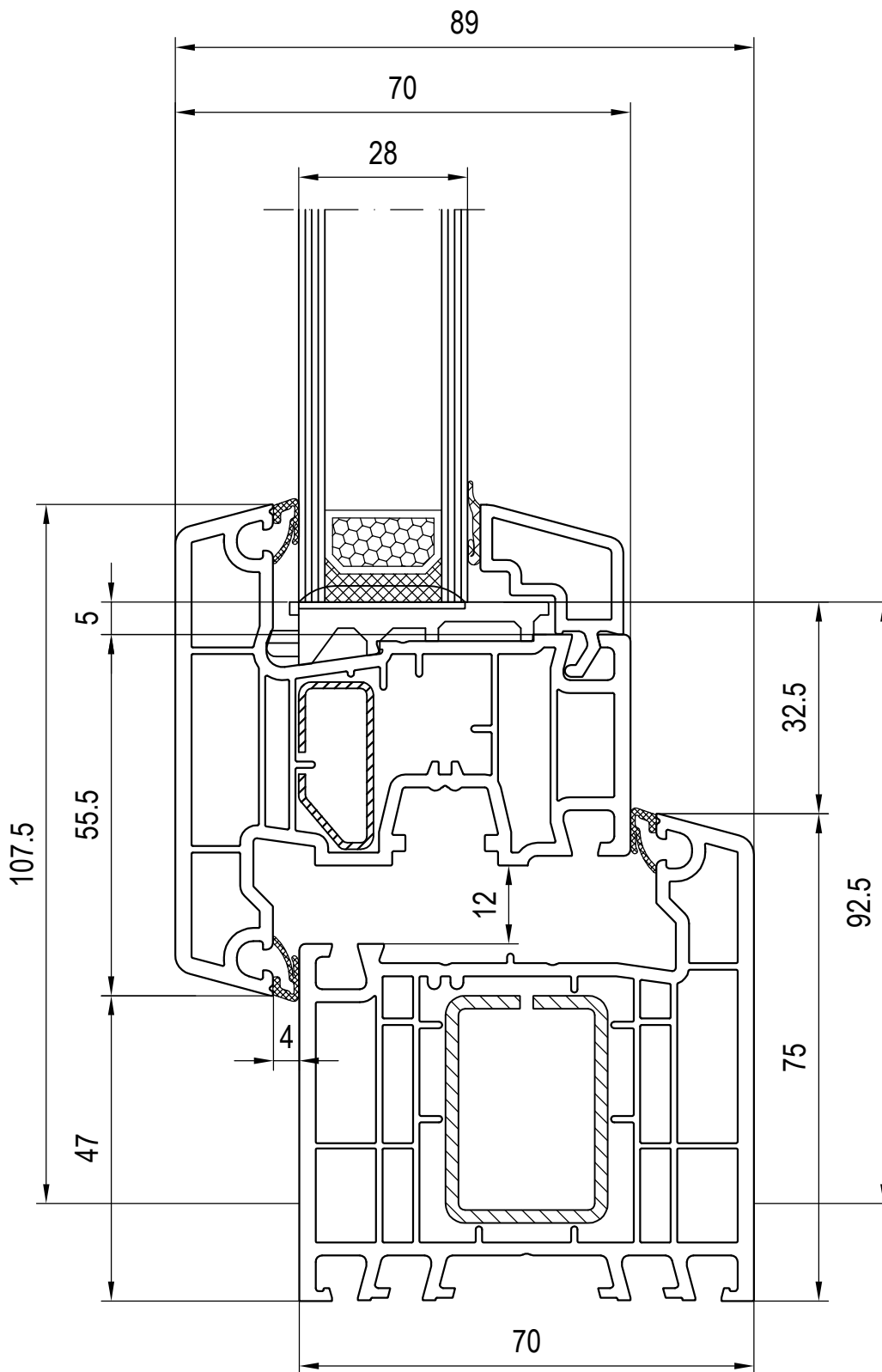

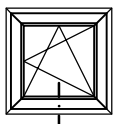
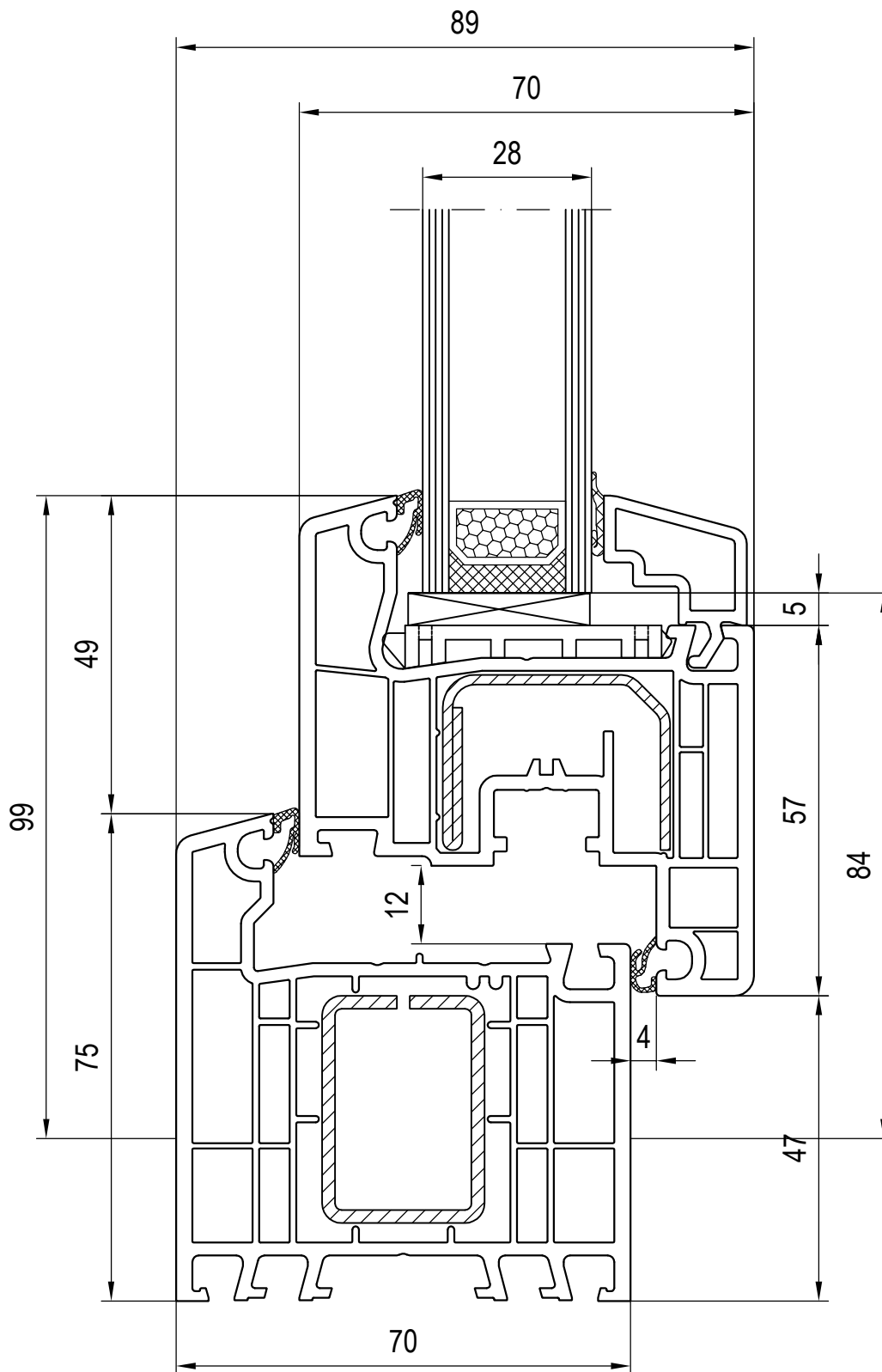

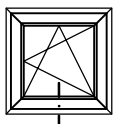
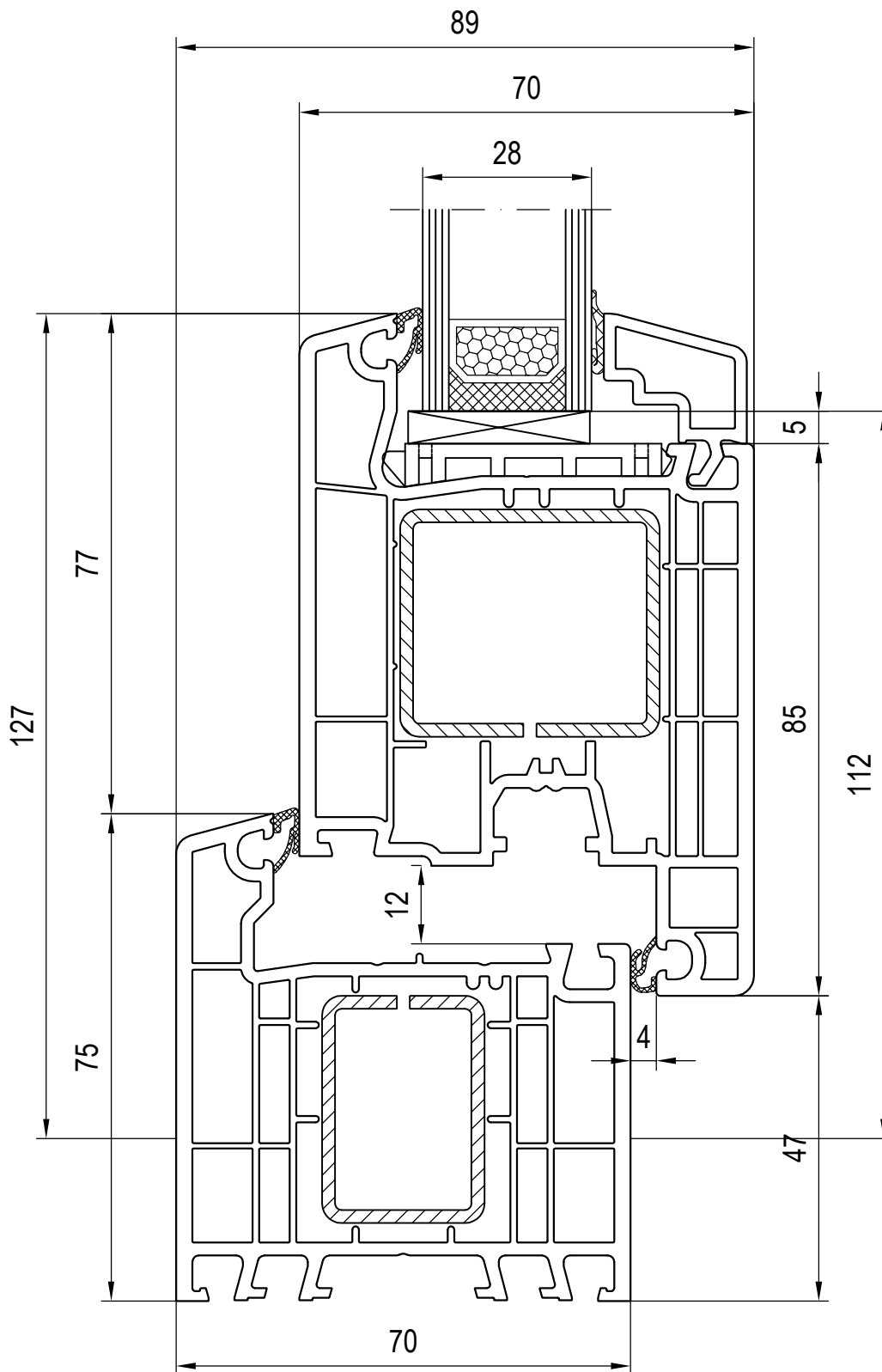

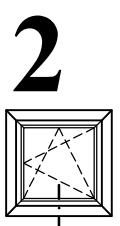
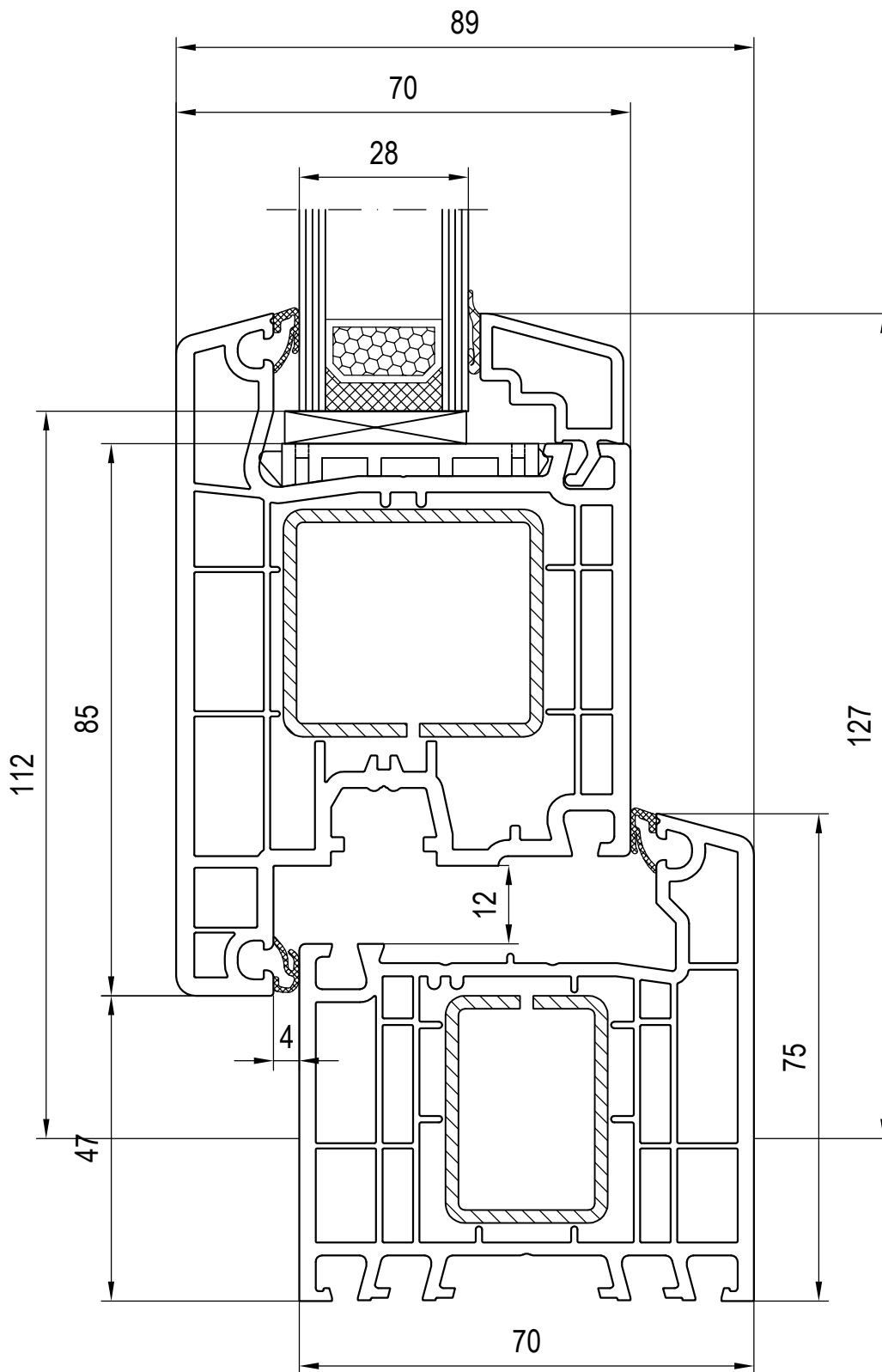

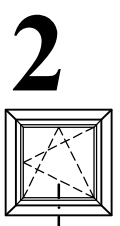
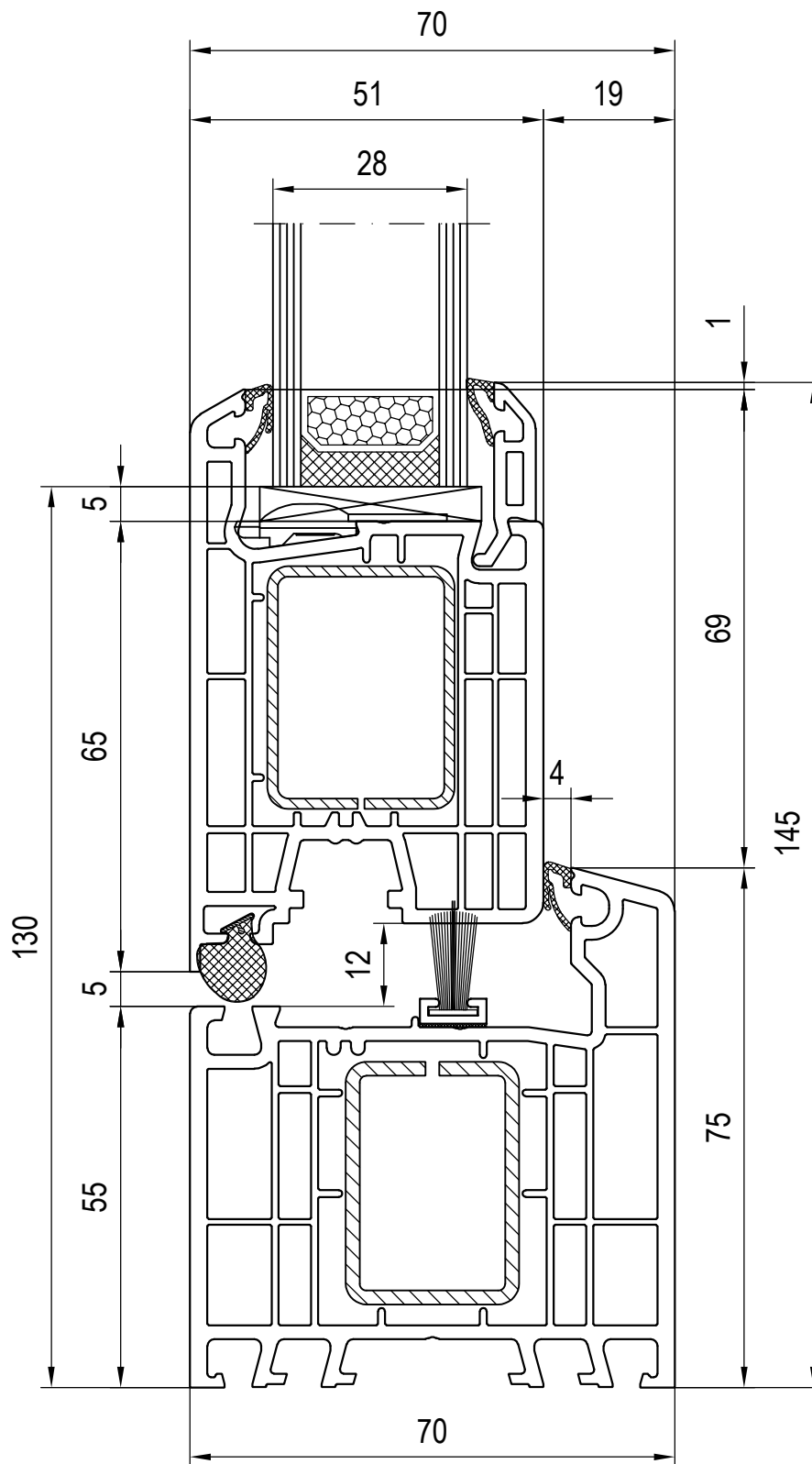

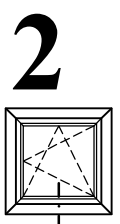
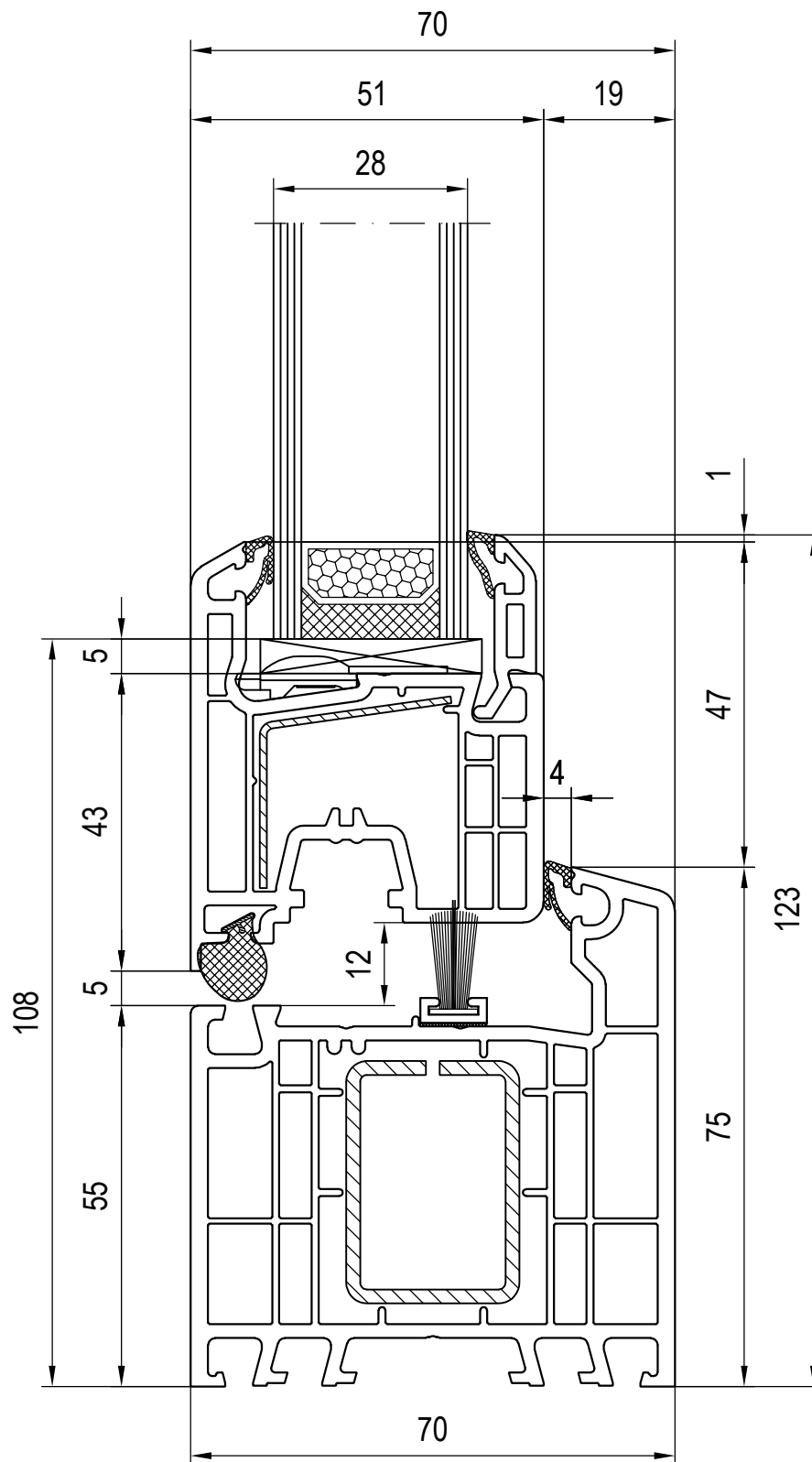

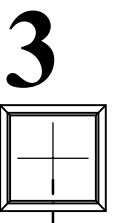
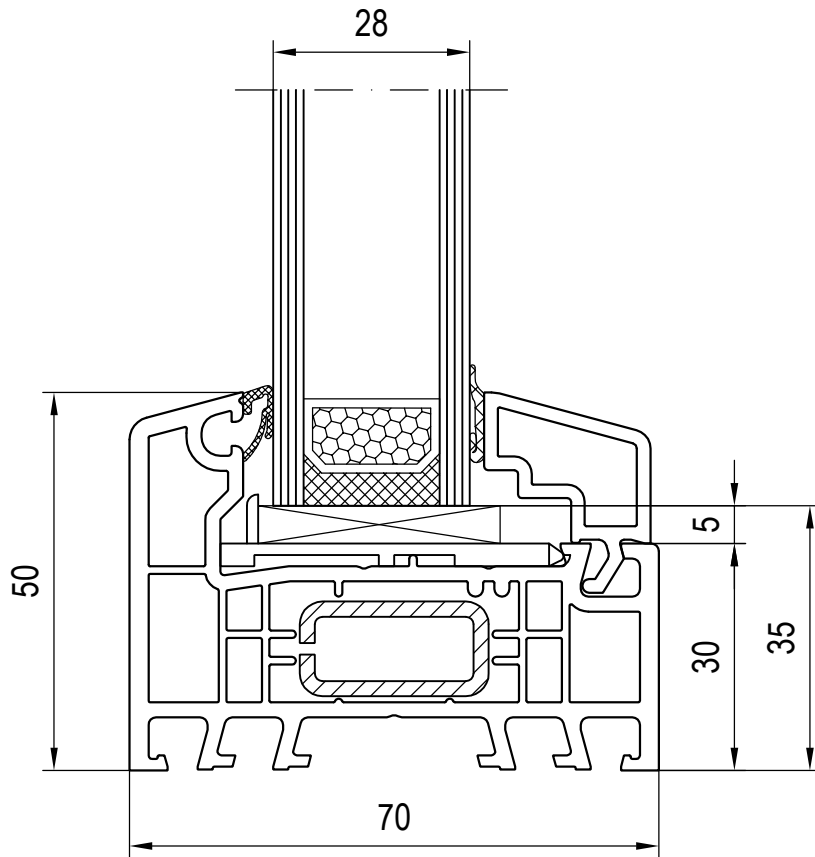

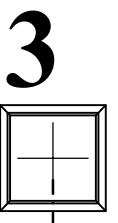
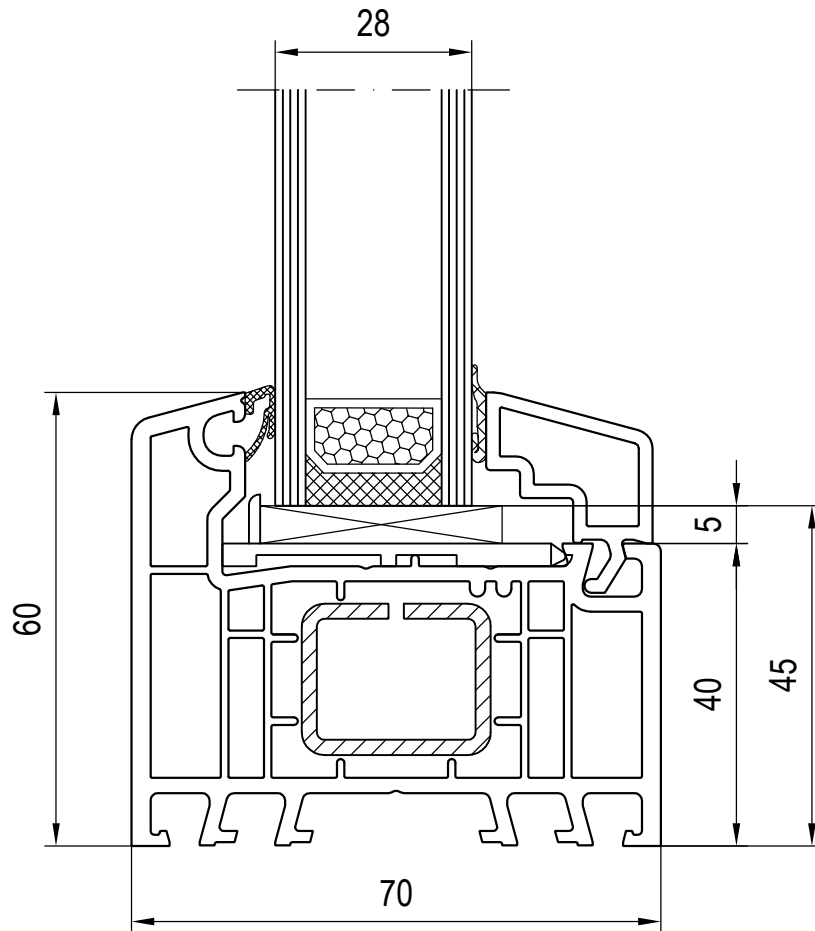

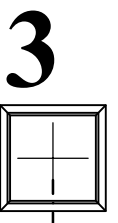
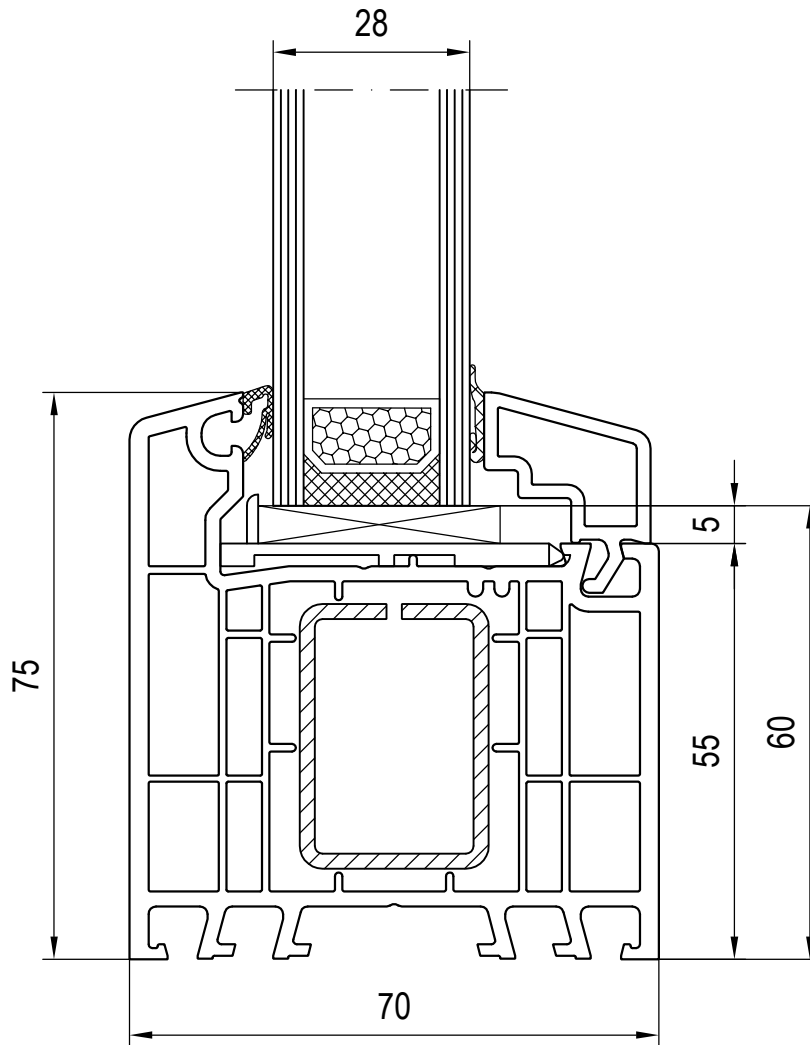

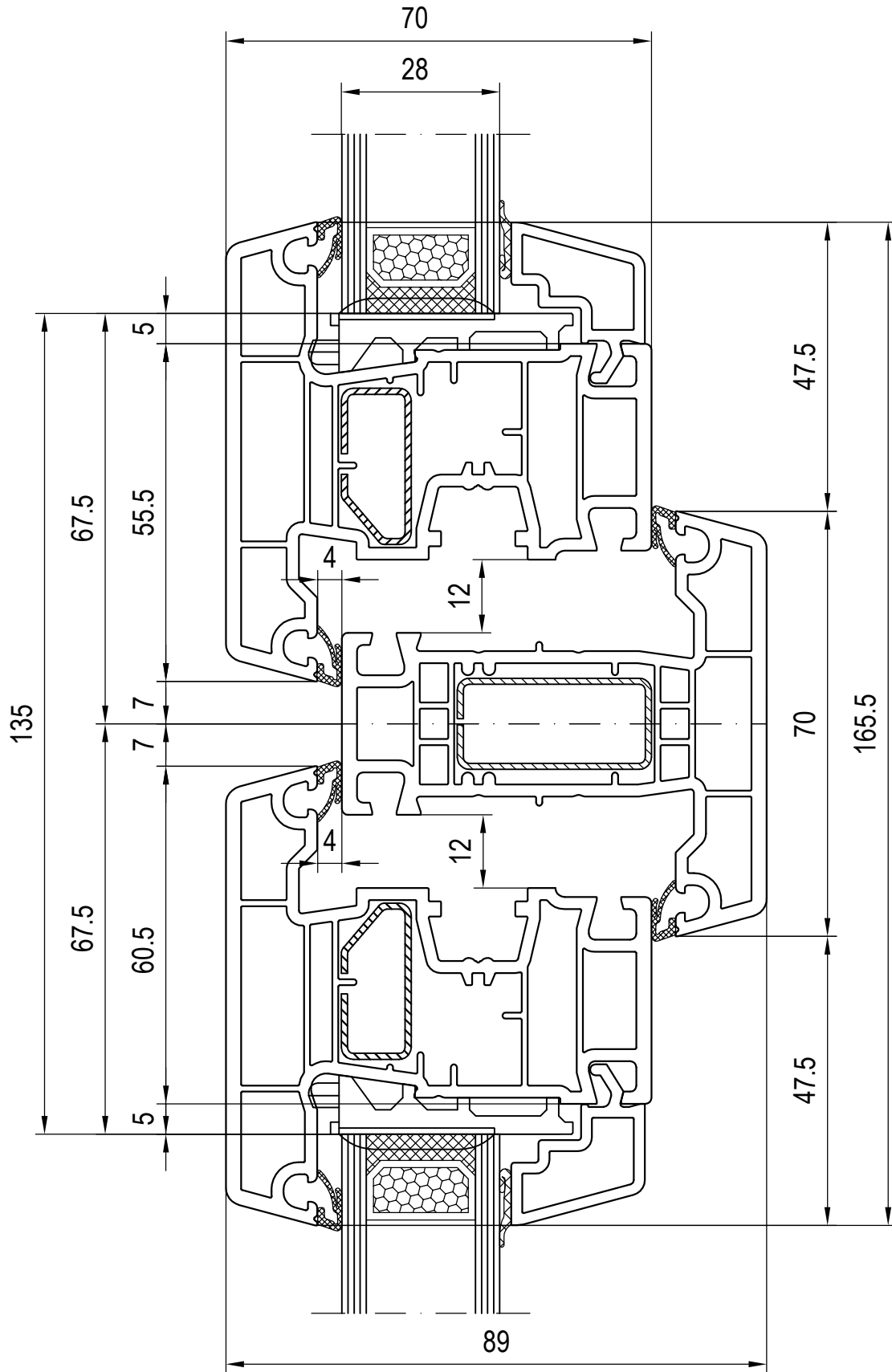

6

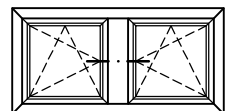

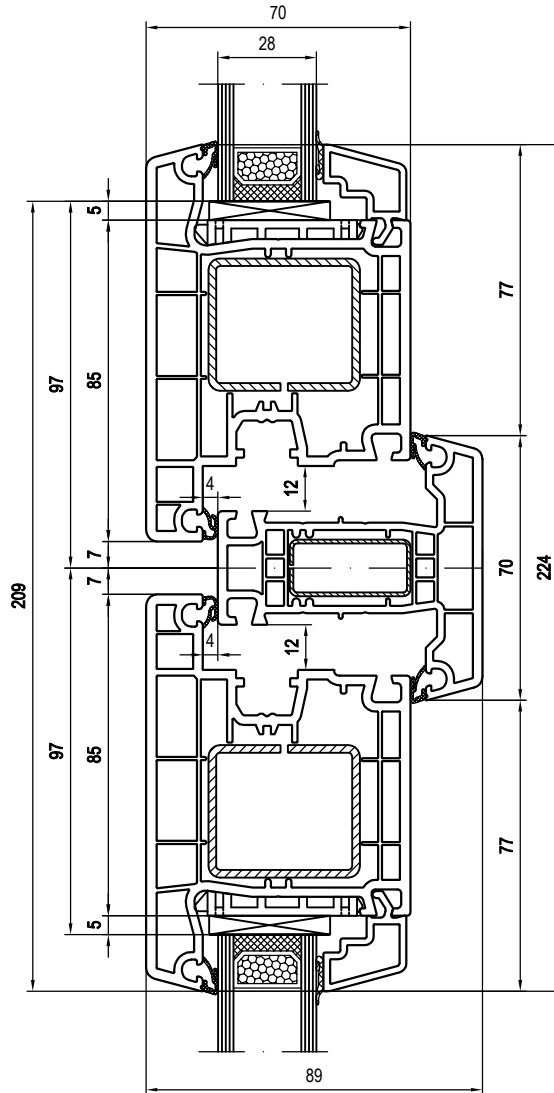

6

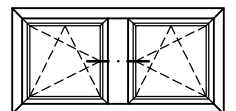

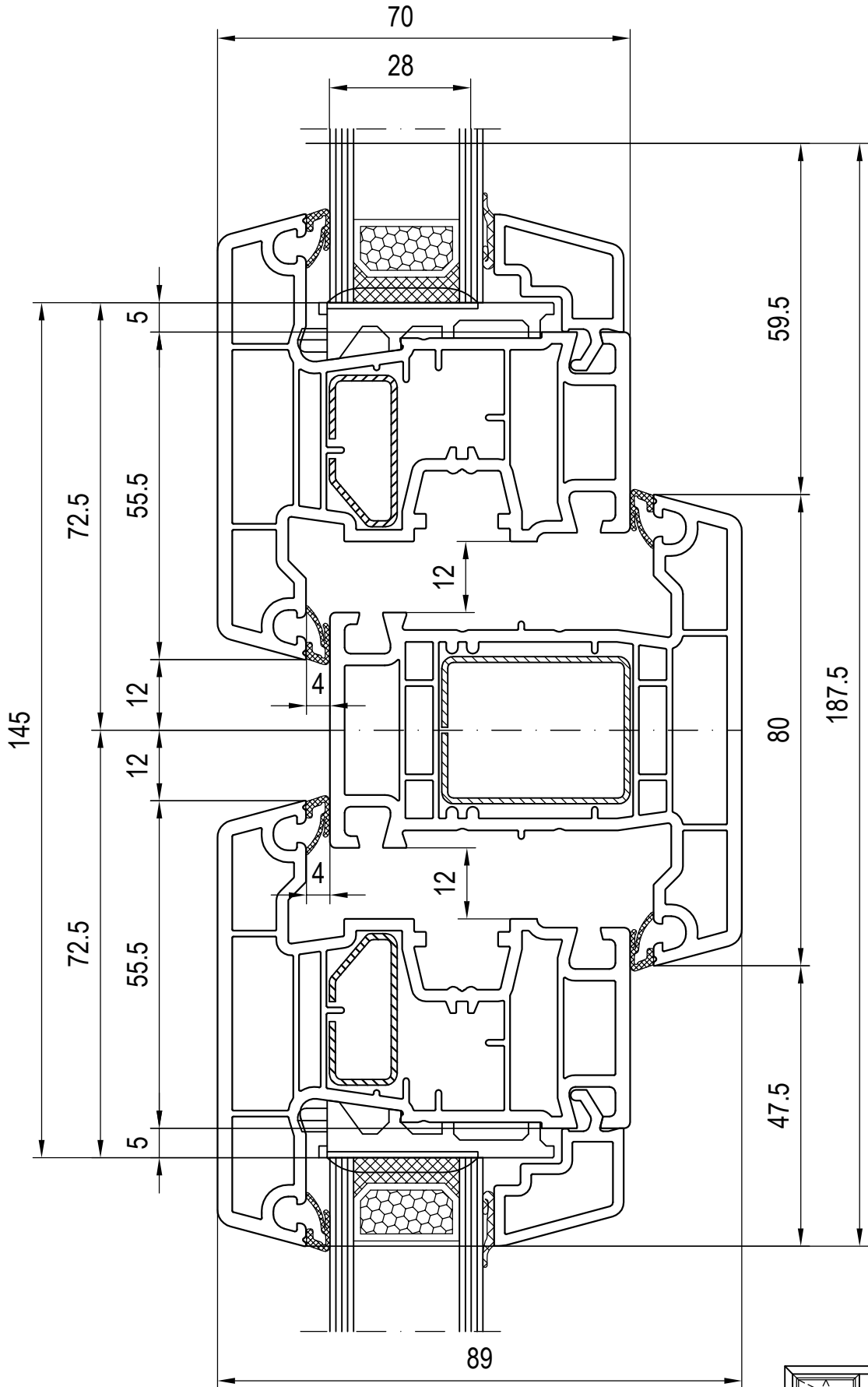

6

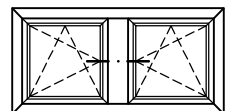

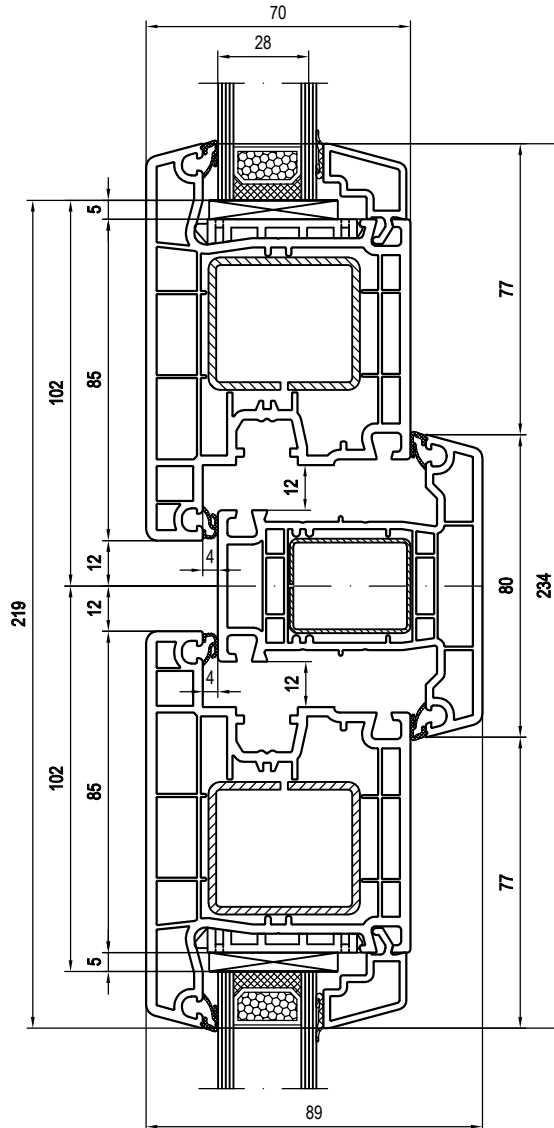

6

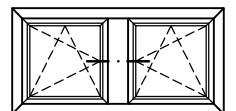

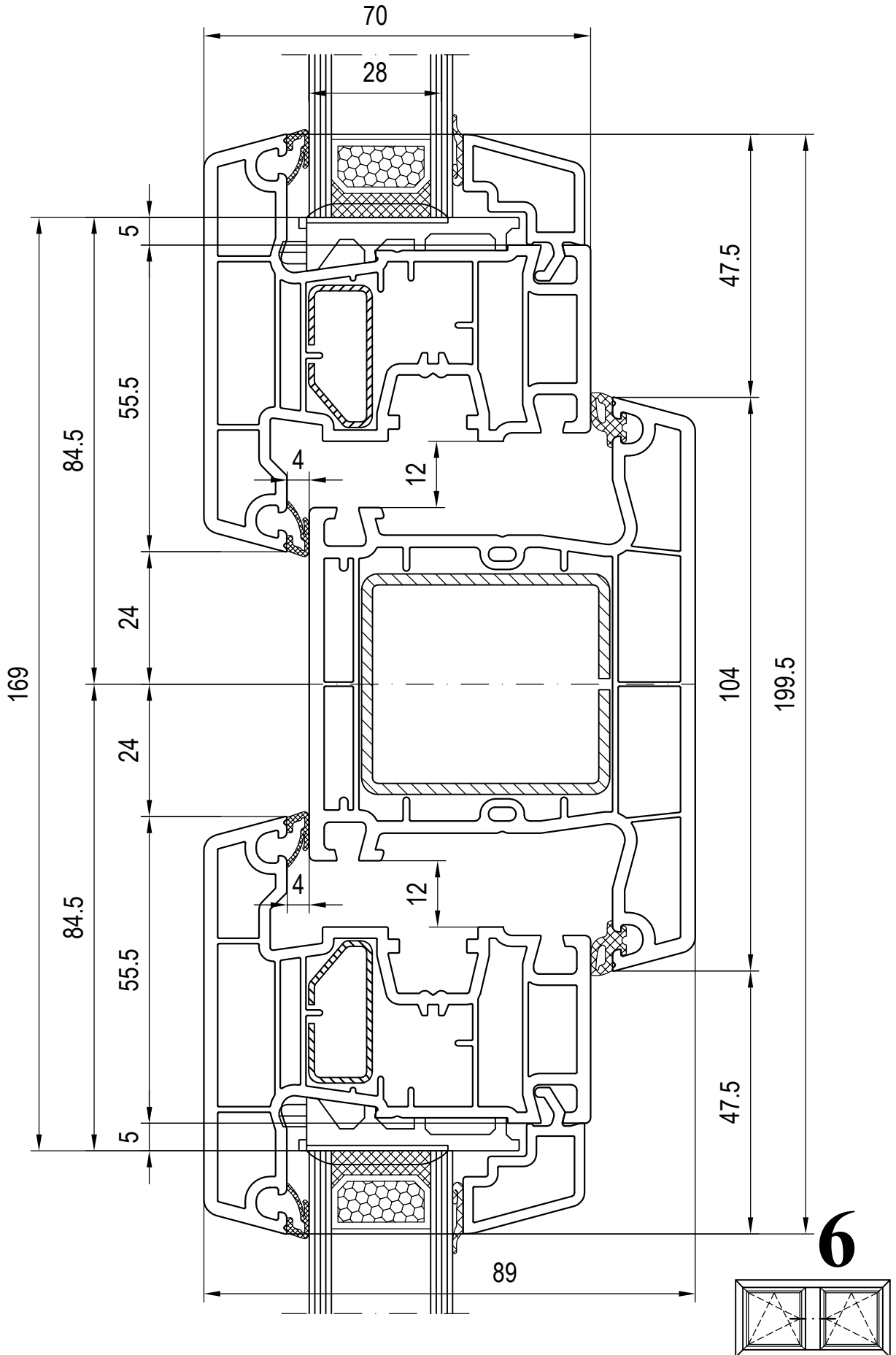

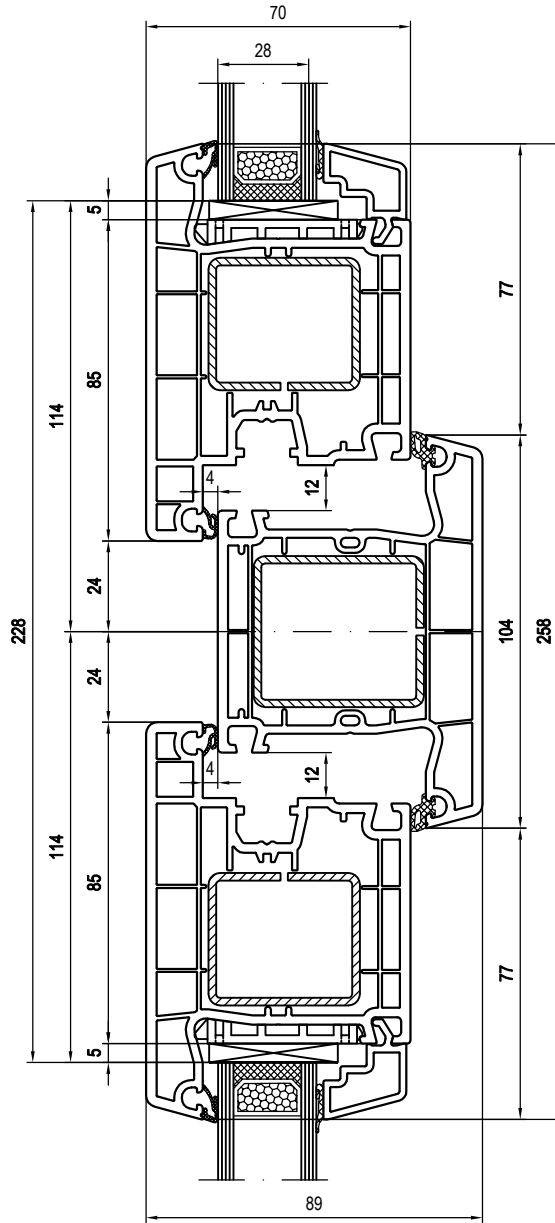

6

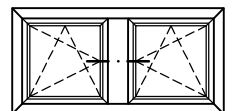

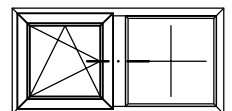
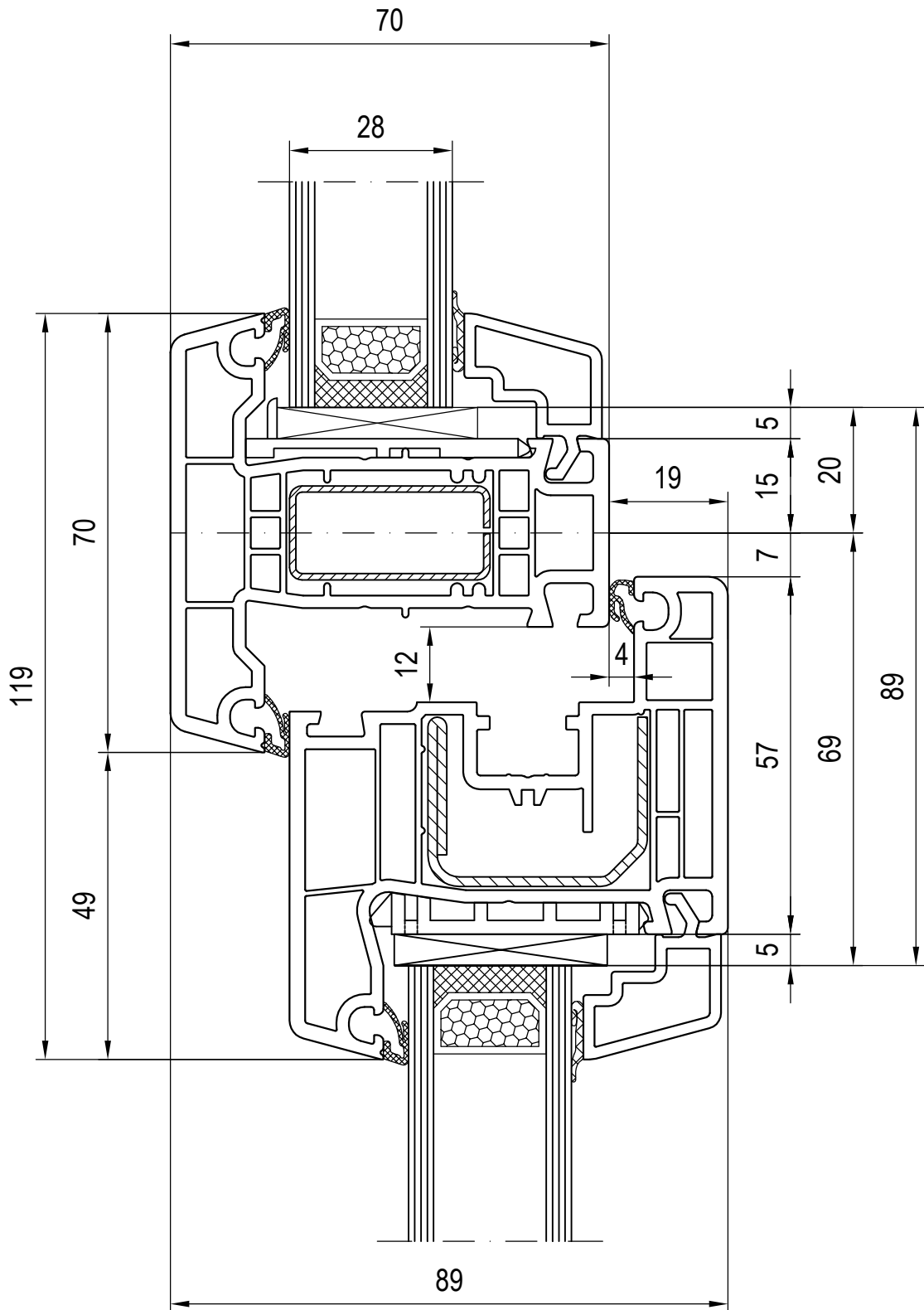

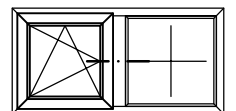
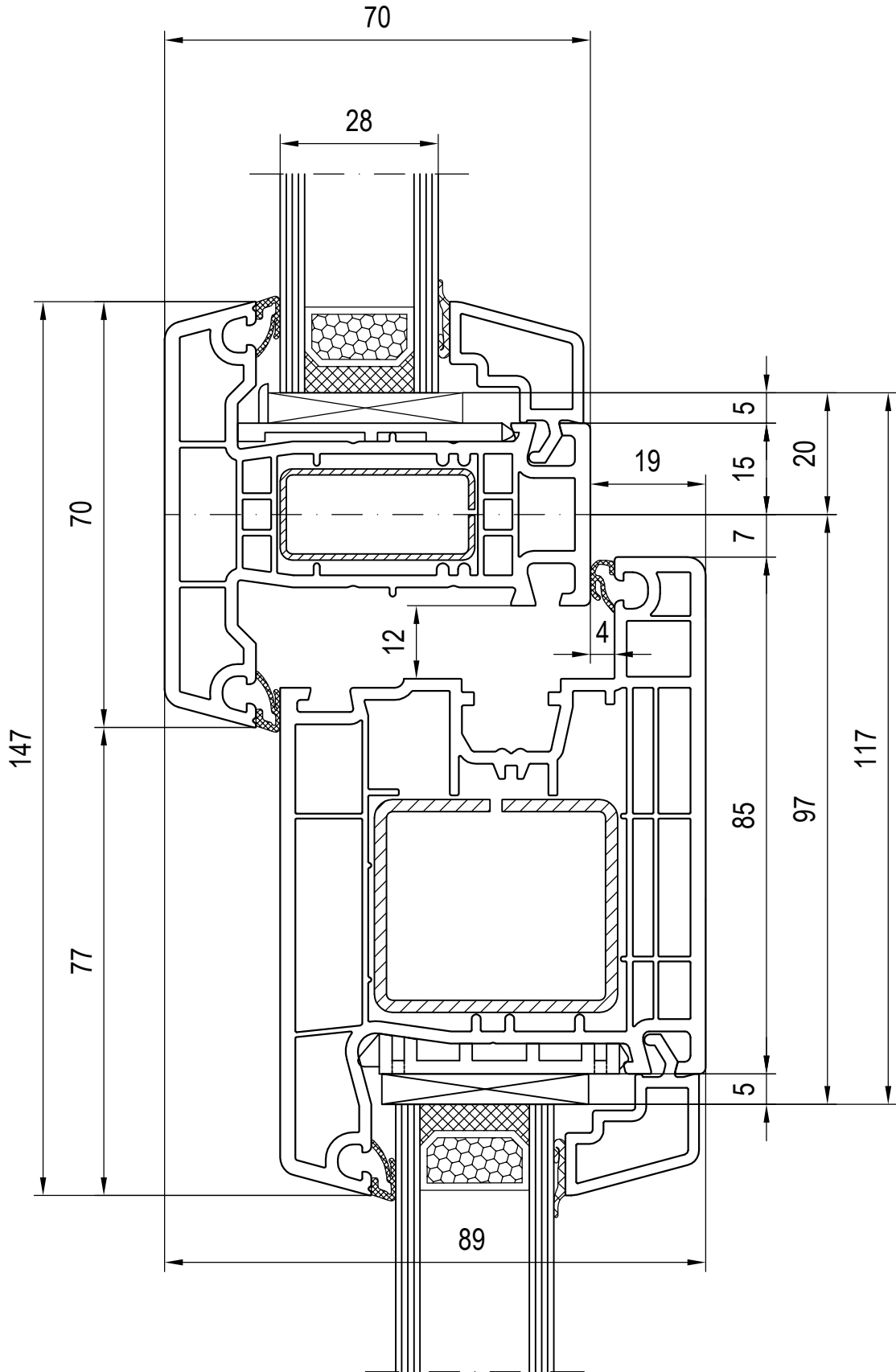

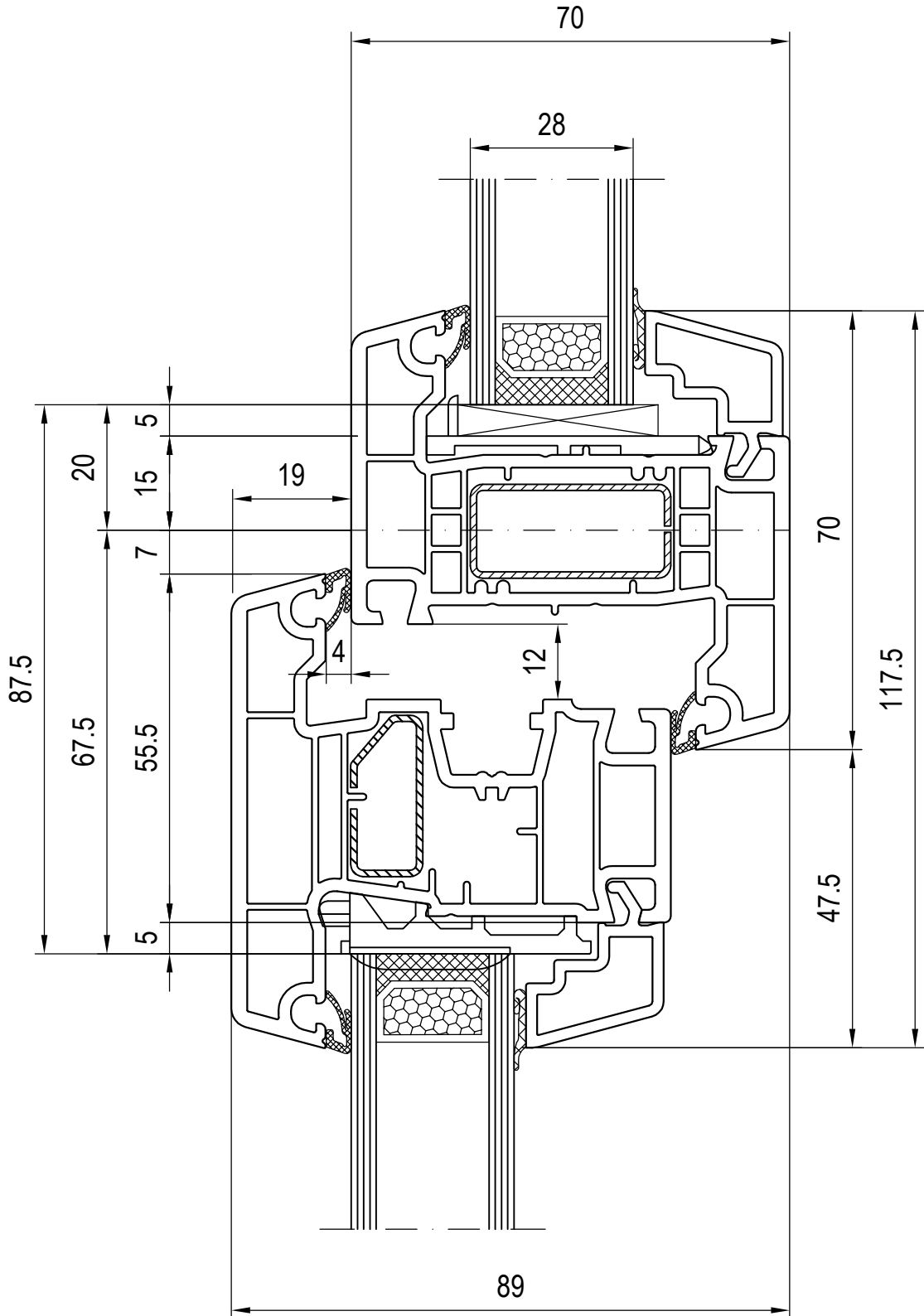

7

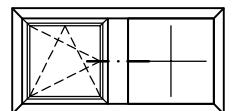

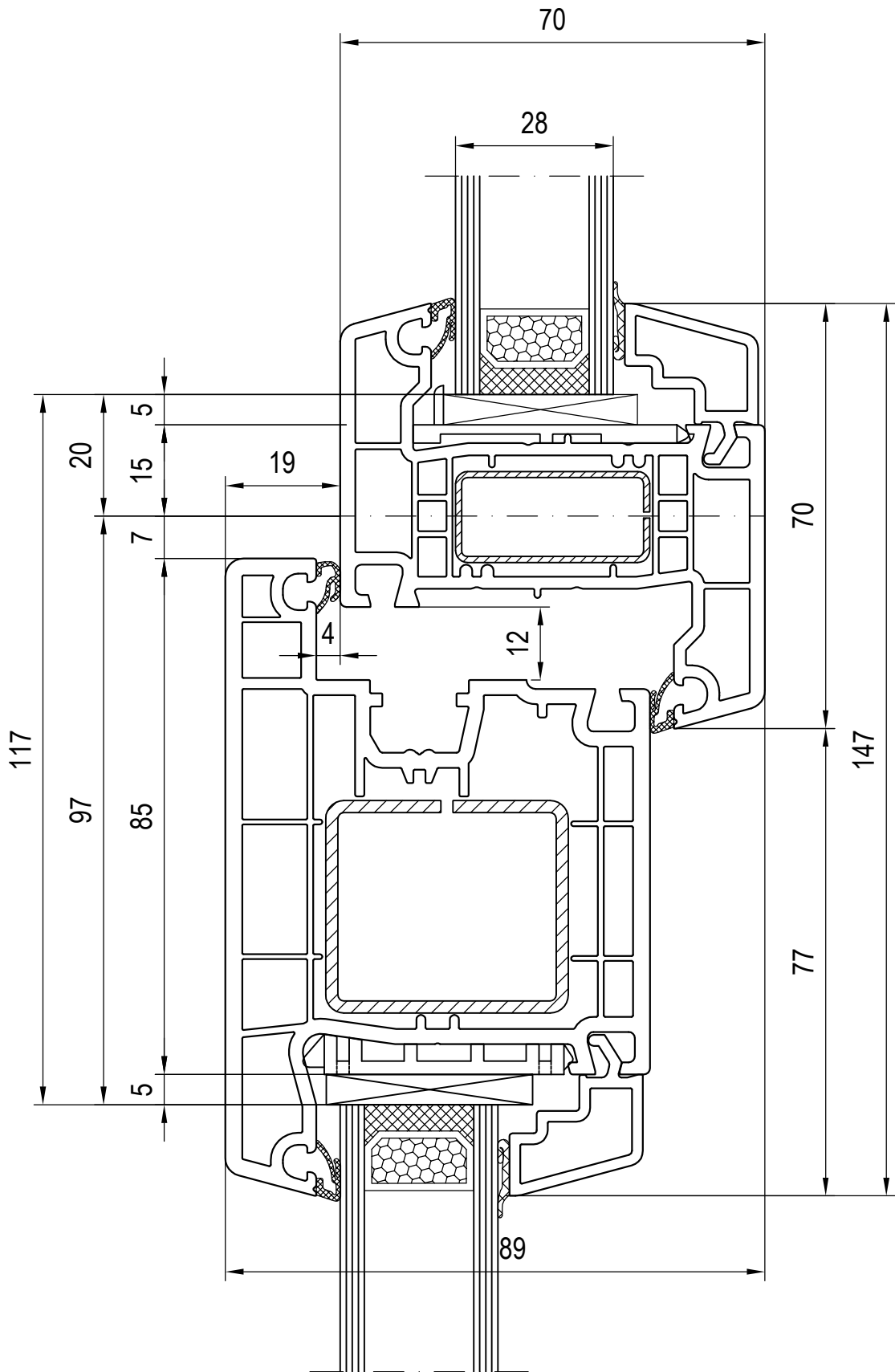

7

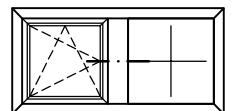

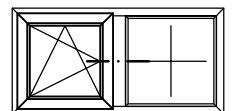
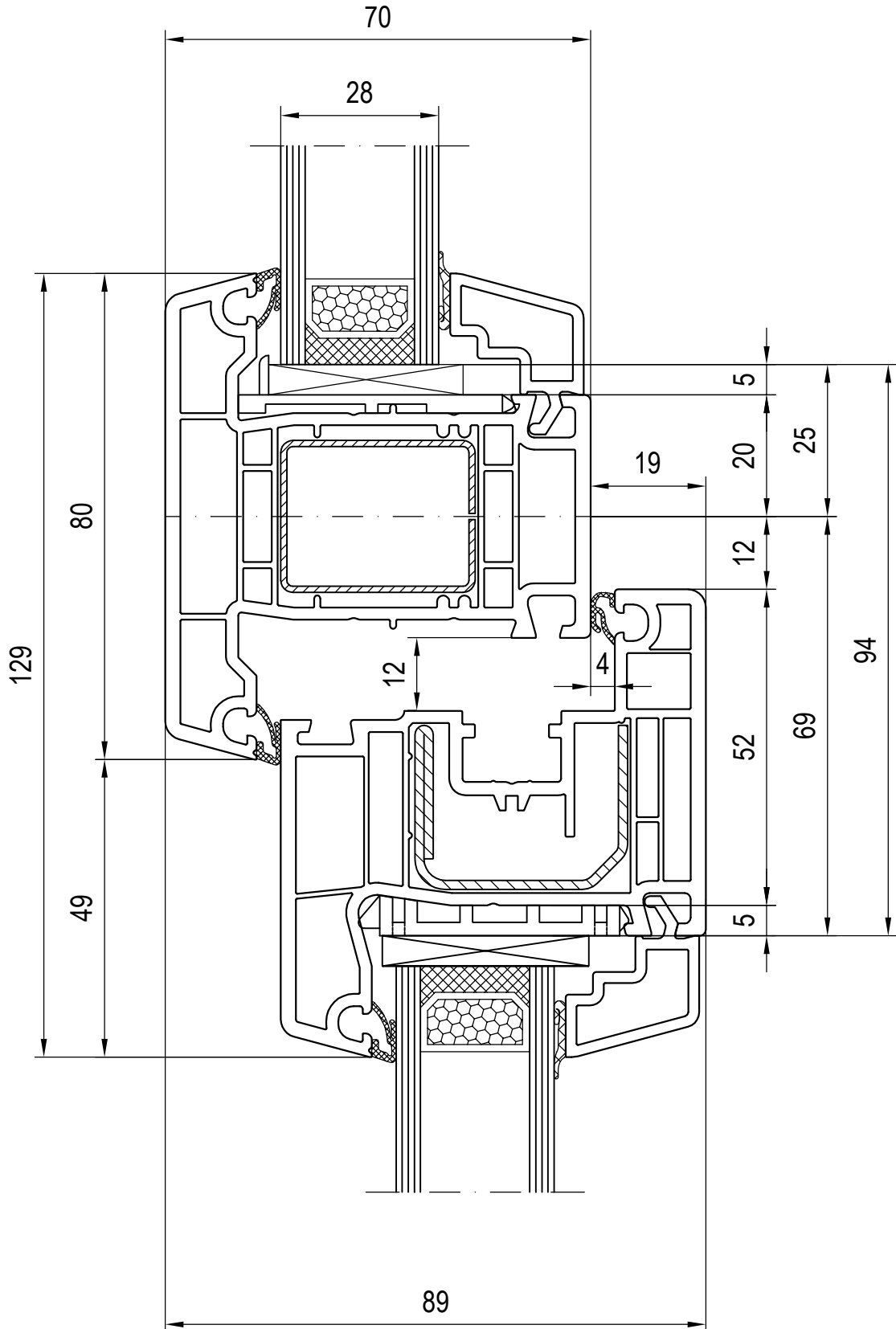

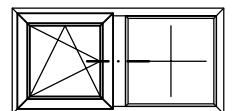
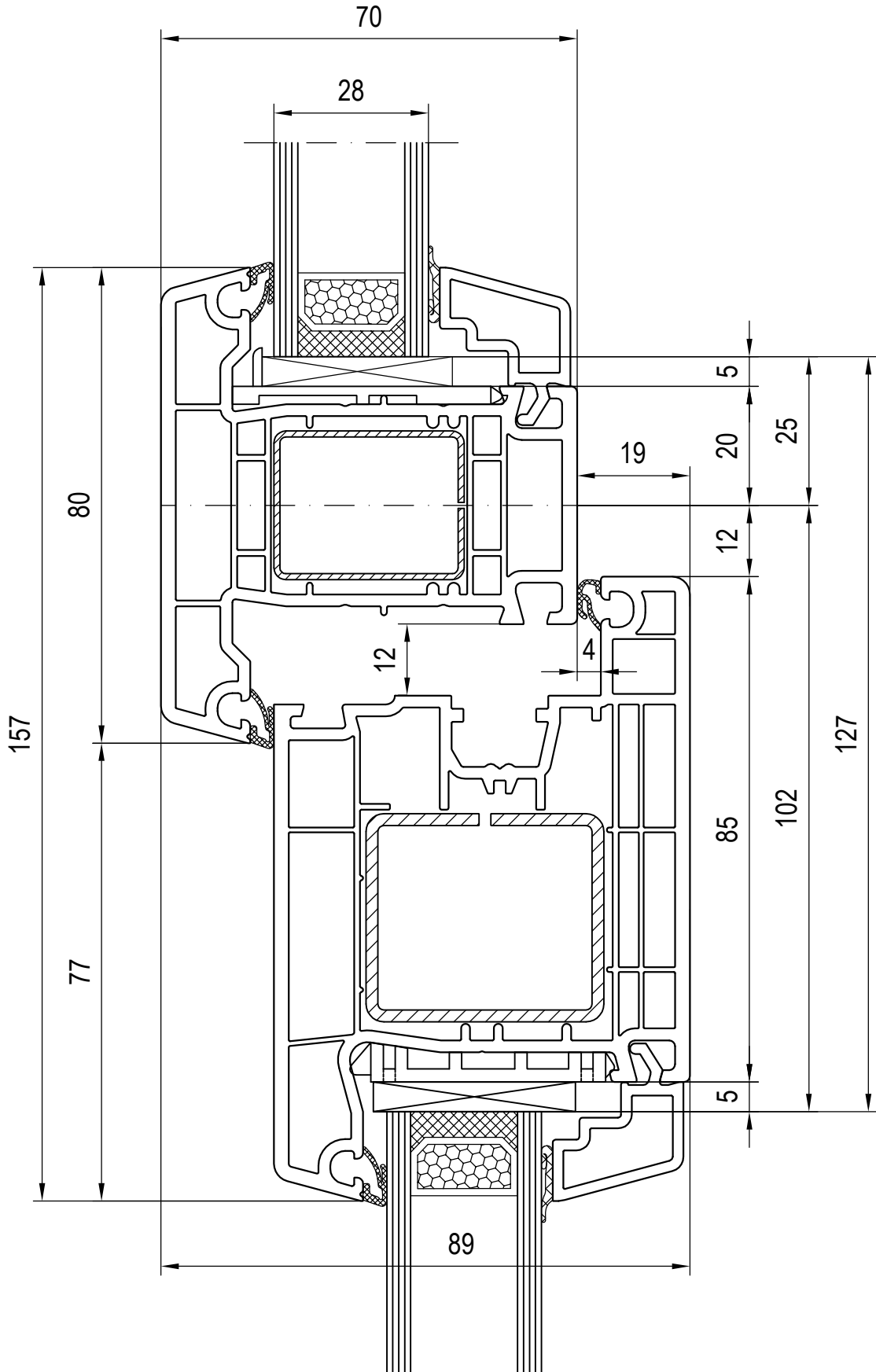

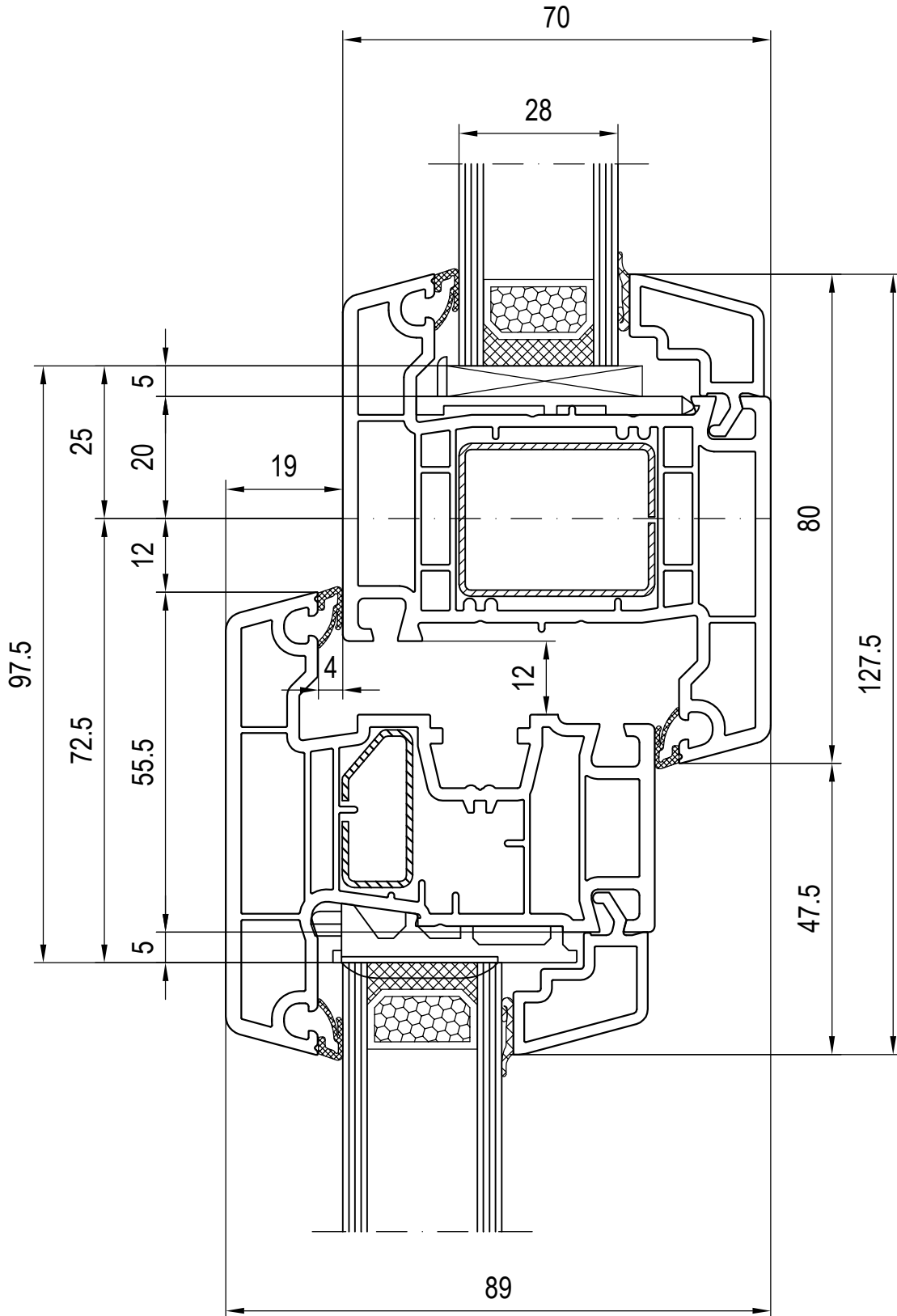

7

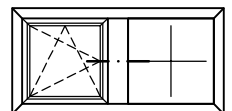

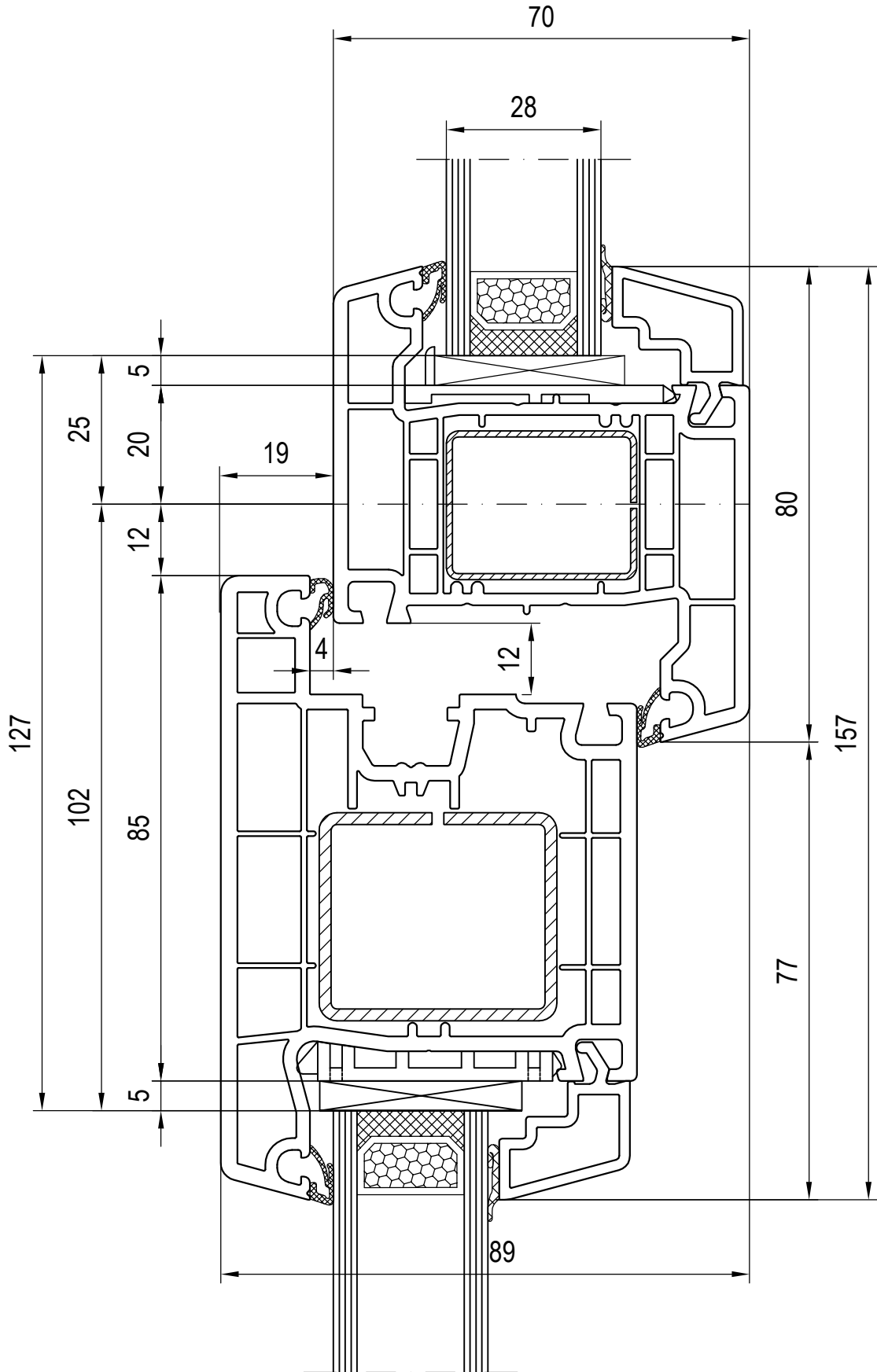

7

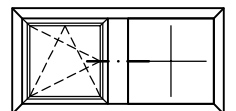

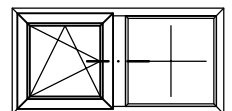
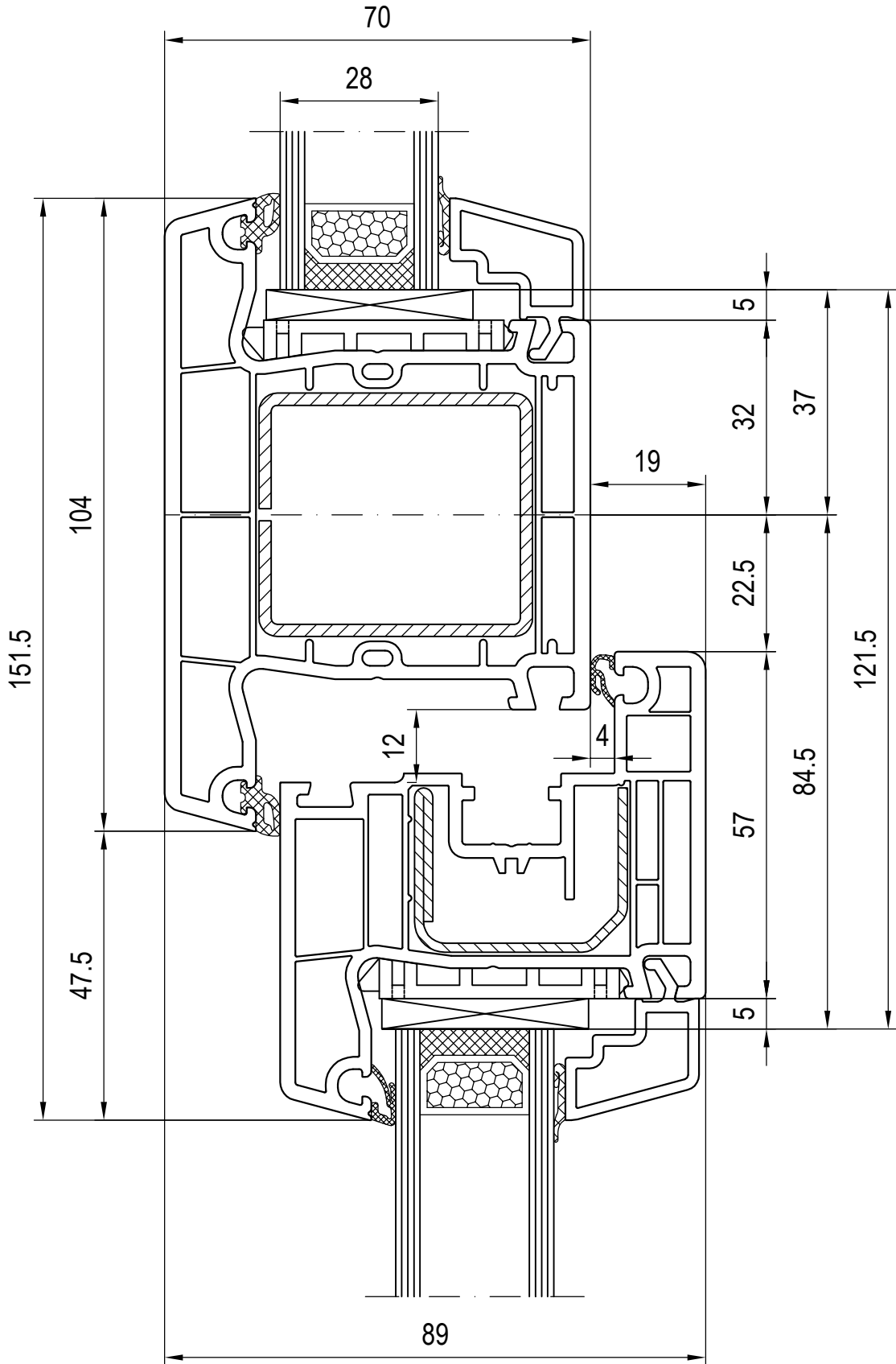

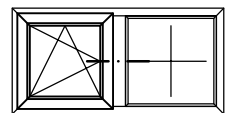
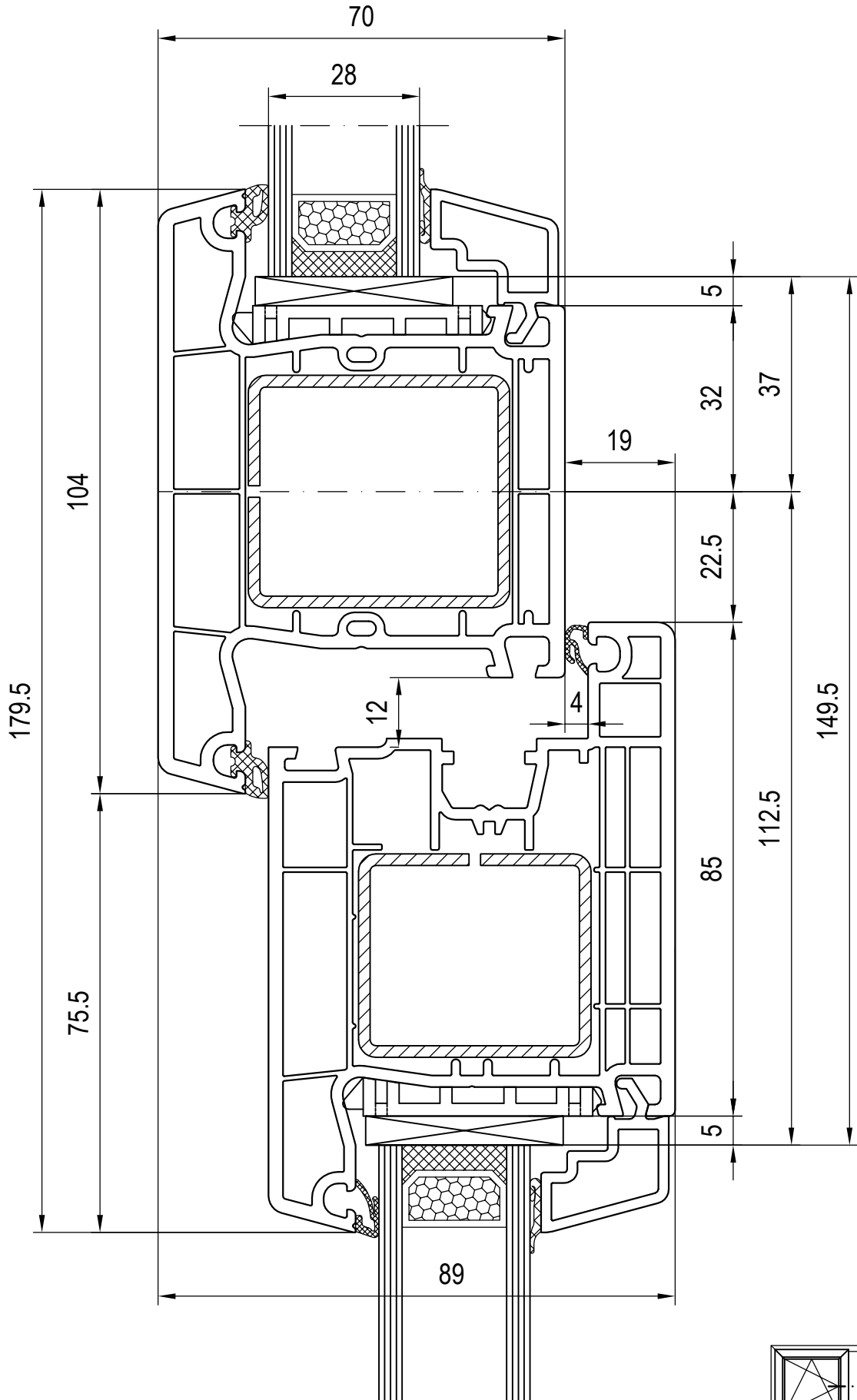

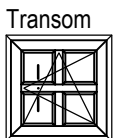
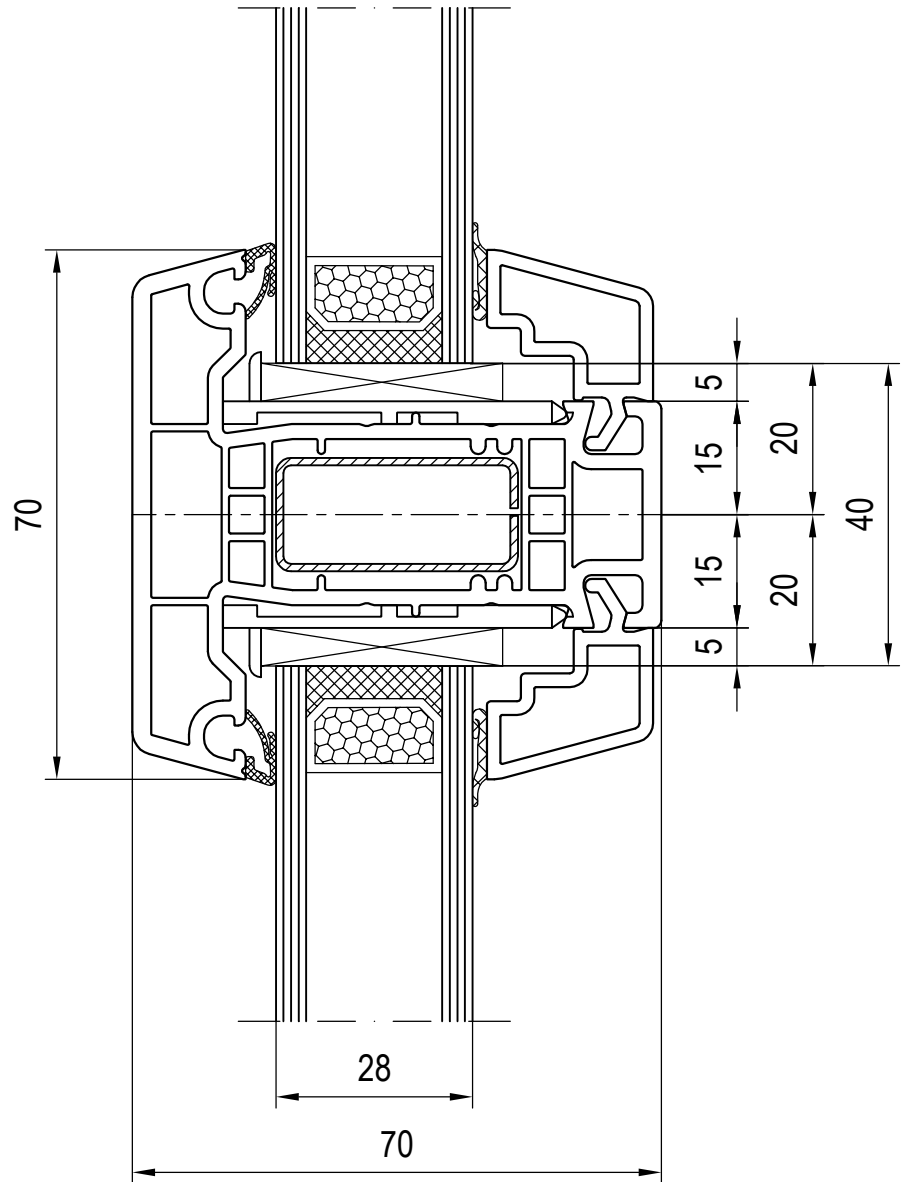

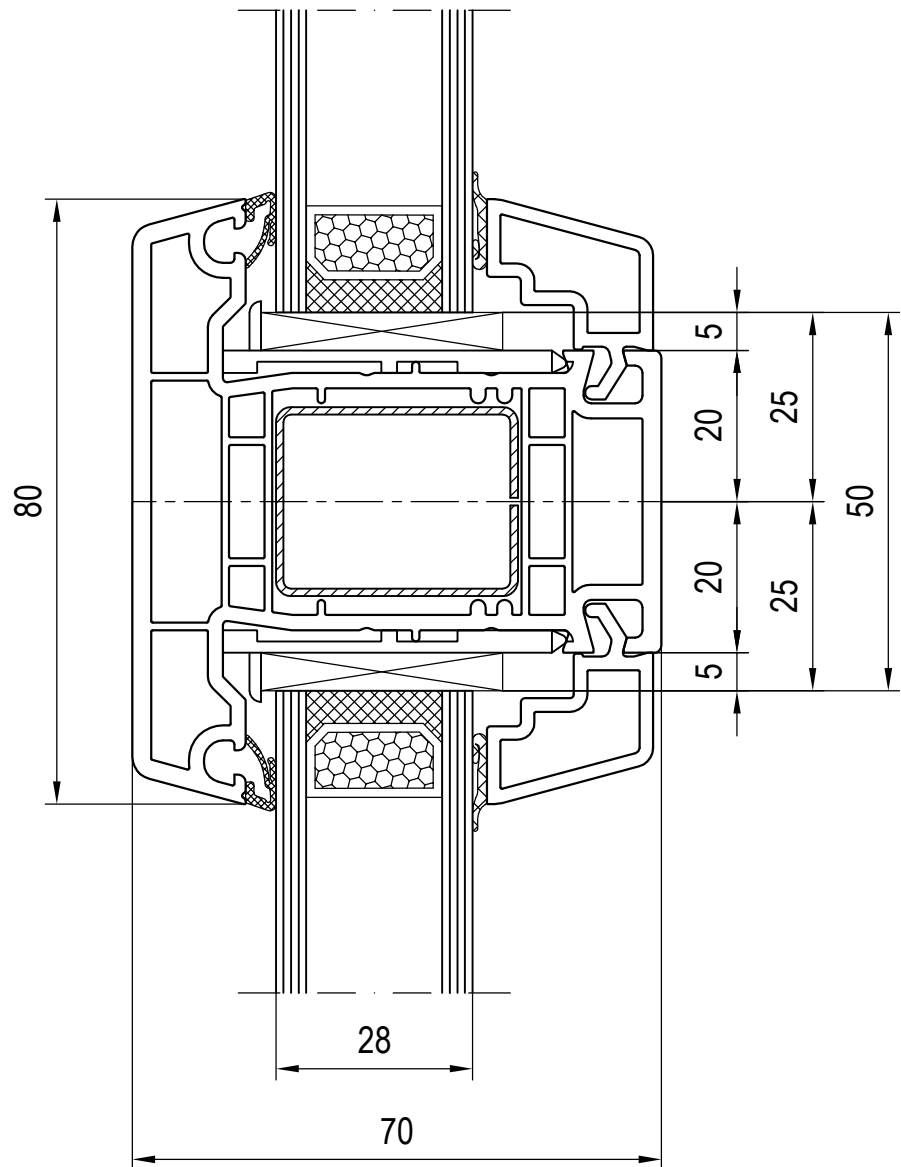

Mullion

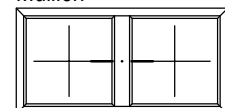

Transom

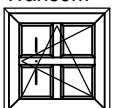

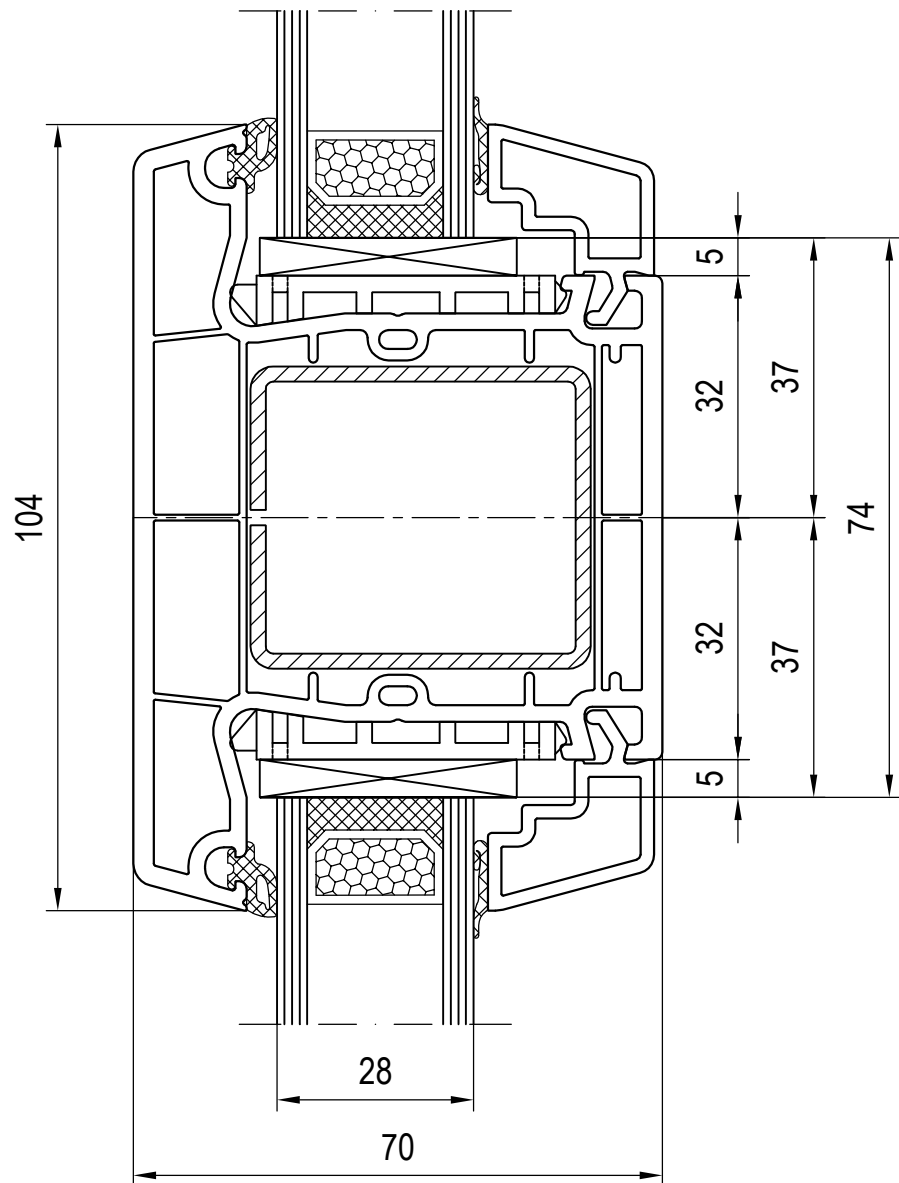

Mullion

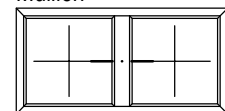

Transom

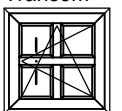

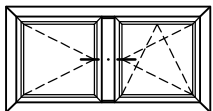
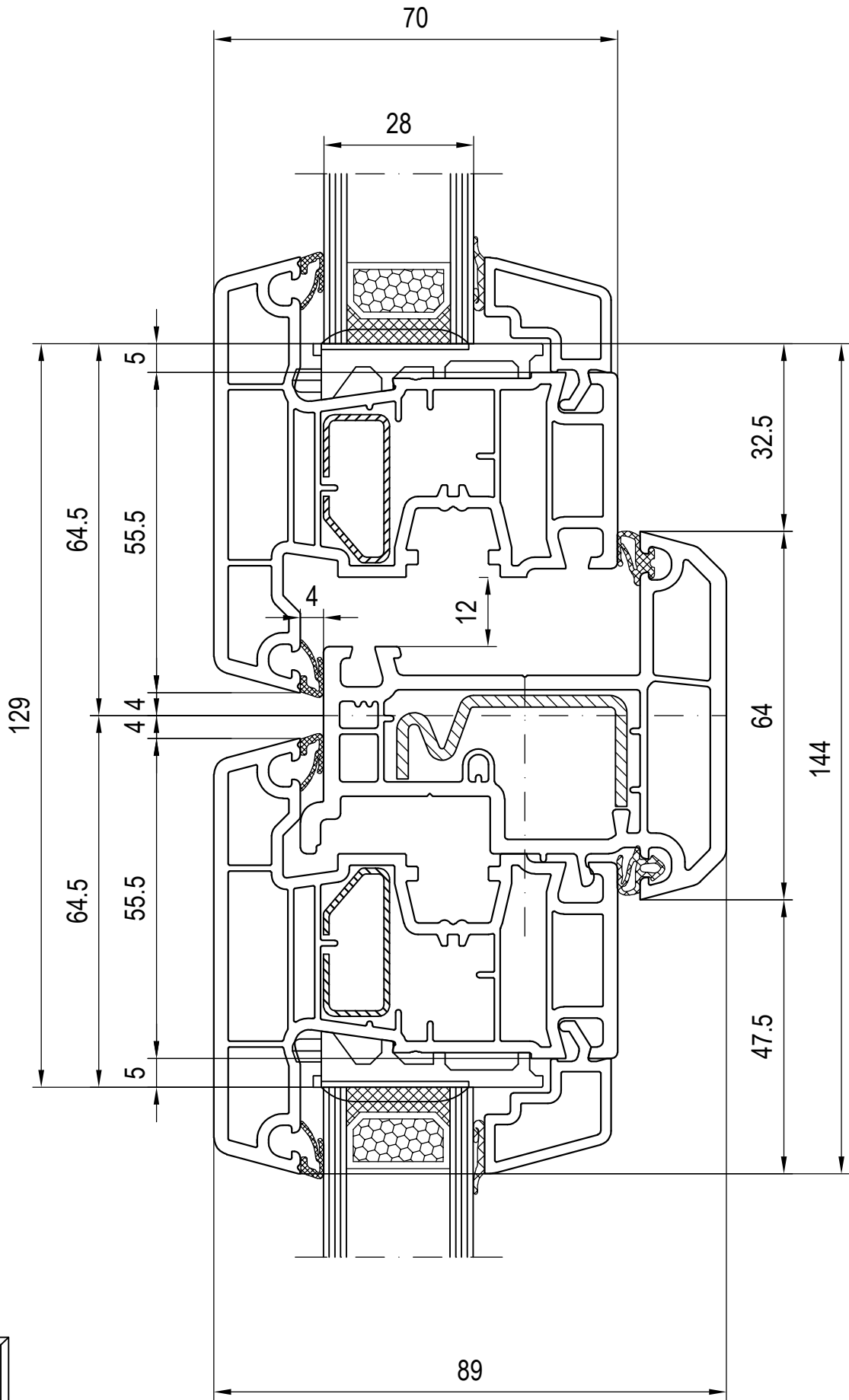

scale 1:1
03_L_01_4IDc_casem*
en May be subject to change and errors excepted!

Combinations: Sash - False Mullion - Sash
120636/120666 Glazing Bead

False mullion 140x67
Sash 100x55

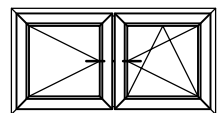
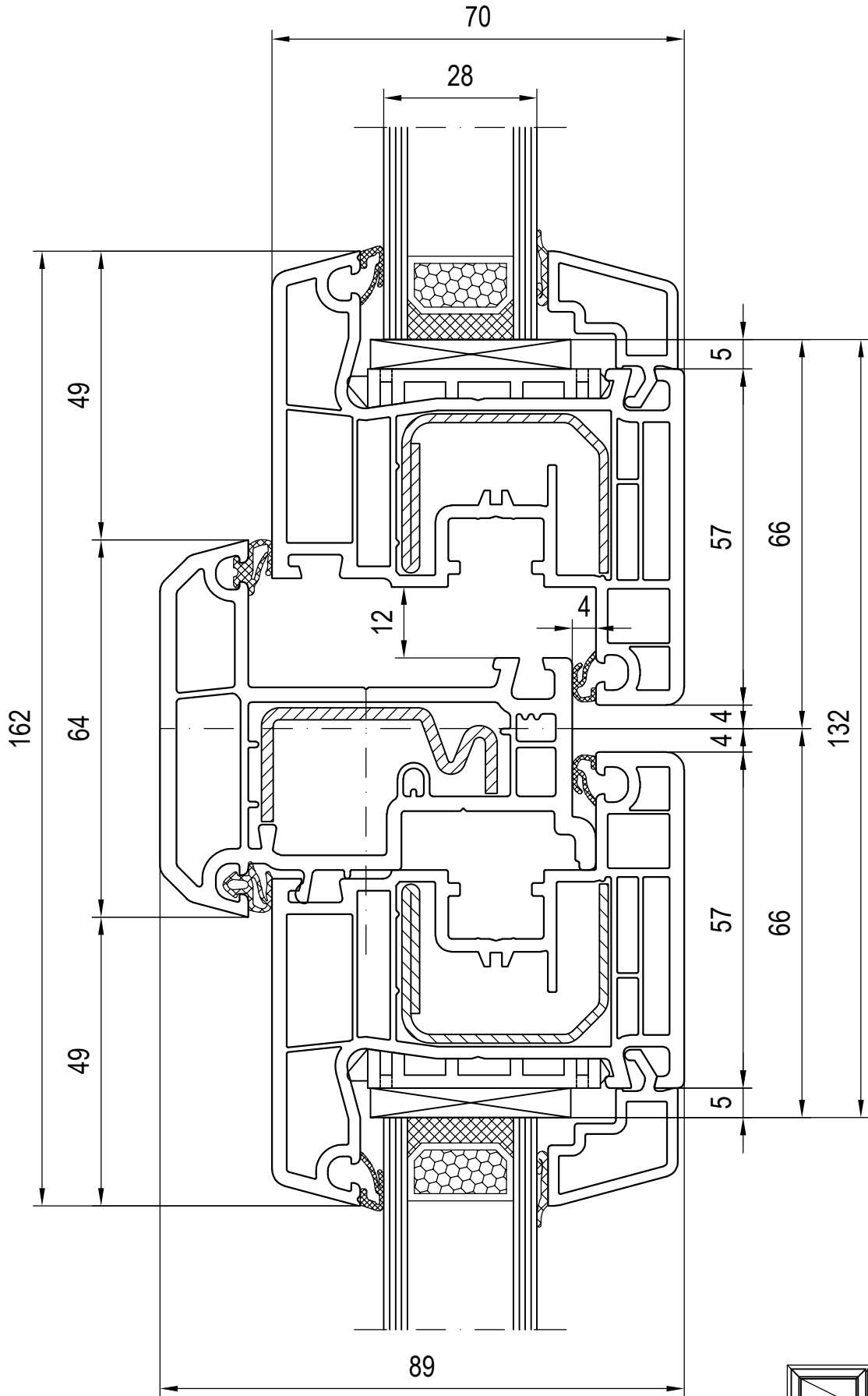

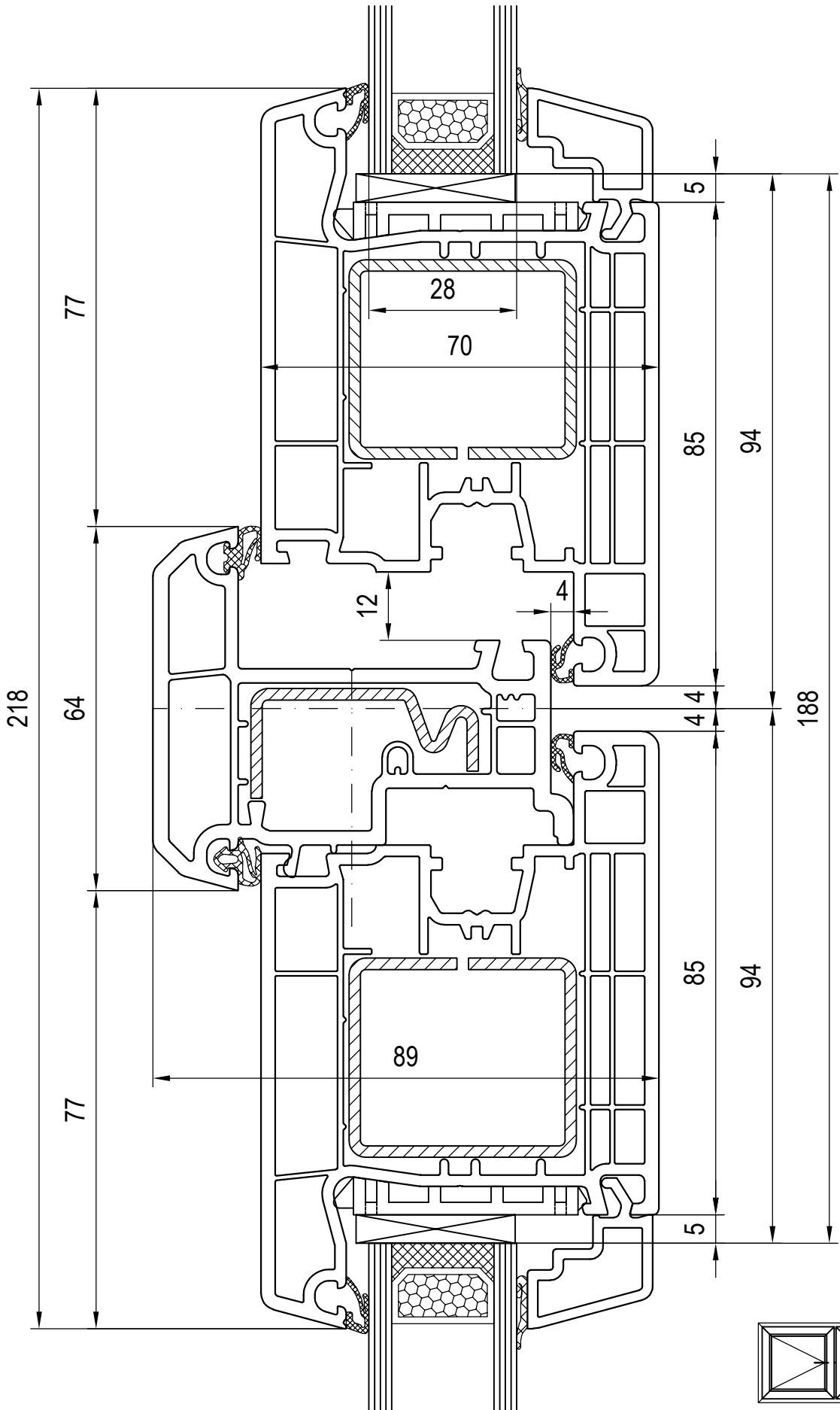

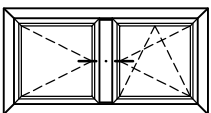
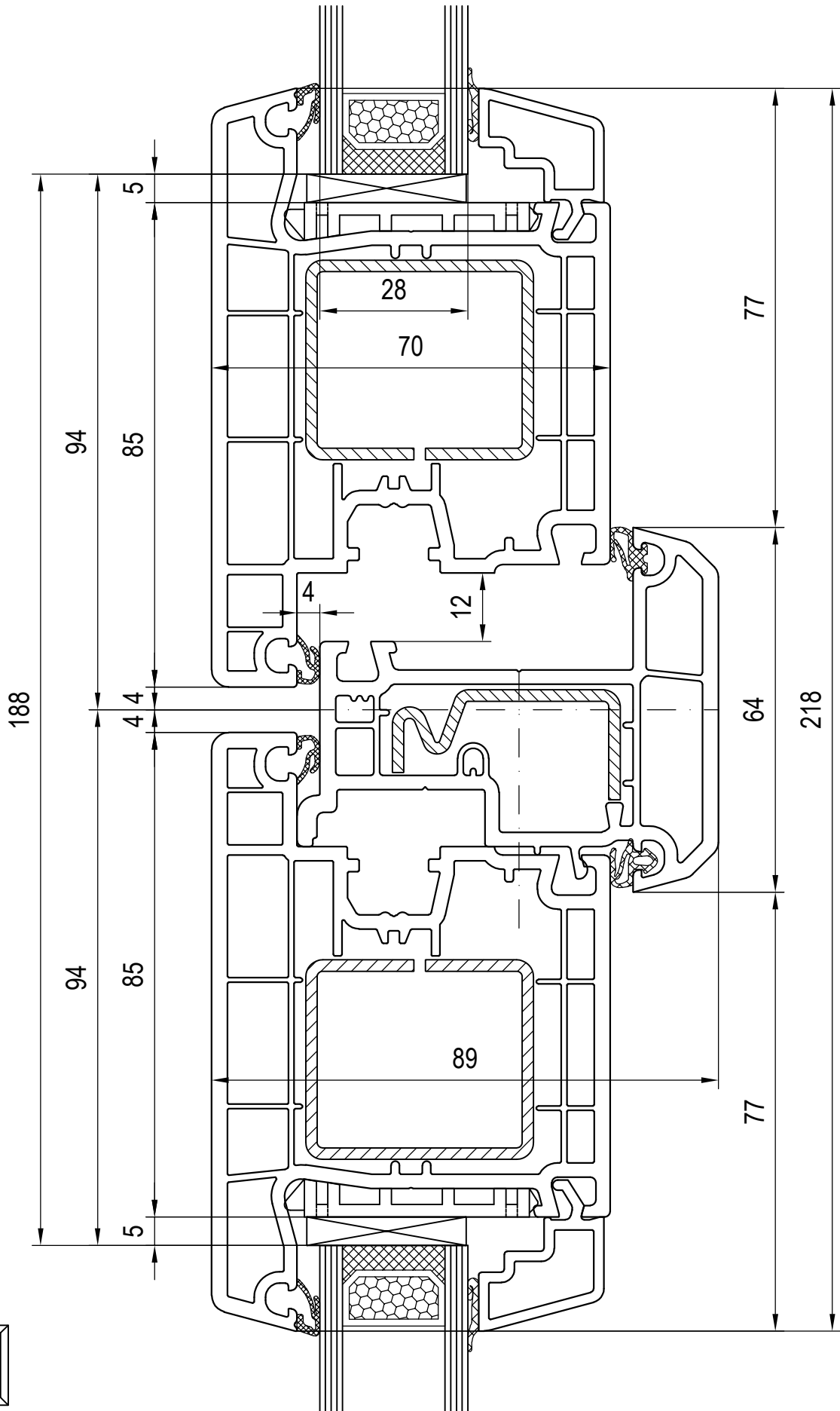

scale 1:1
03_L_01_4IDc_casem*
en May be subject to change and errors excepted!

Combinations: Sash - False Mullion - Sash
120636/120666 Glazing Bead

False mullion 140x67
Sash 140x31

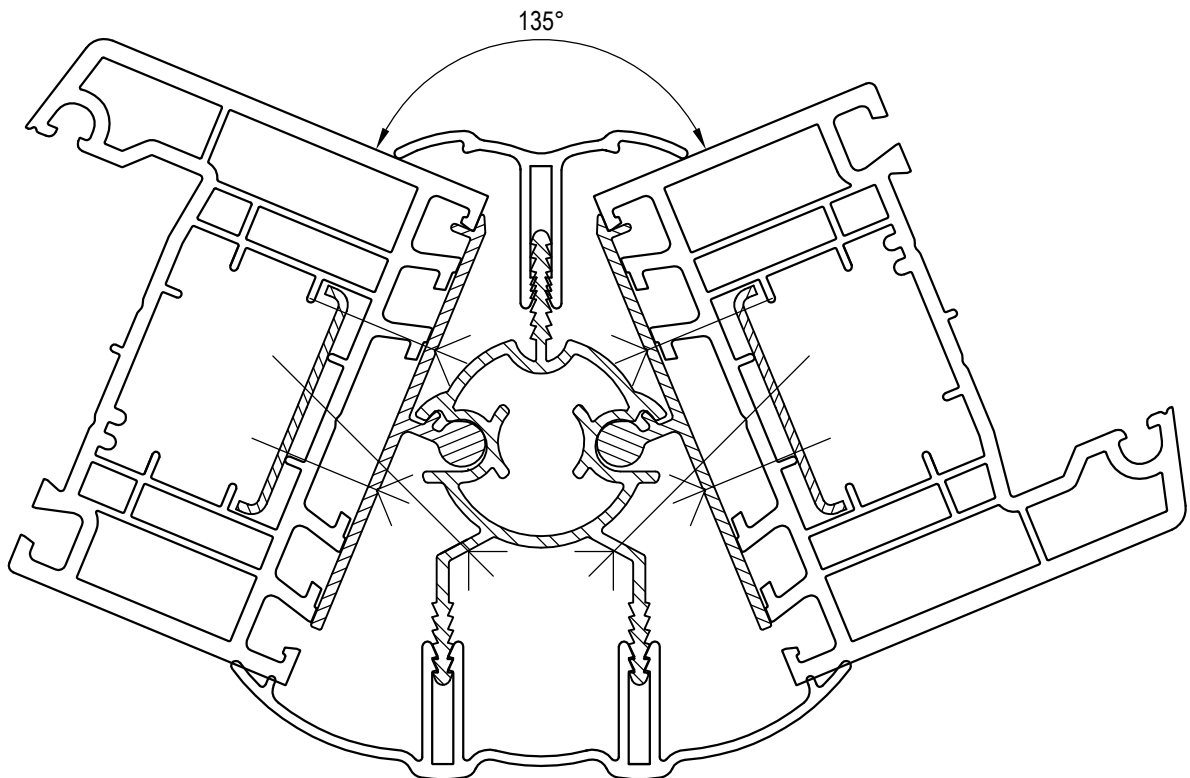
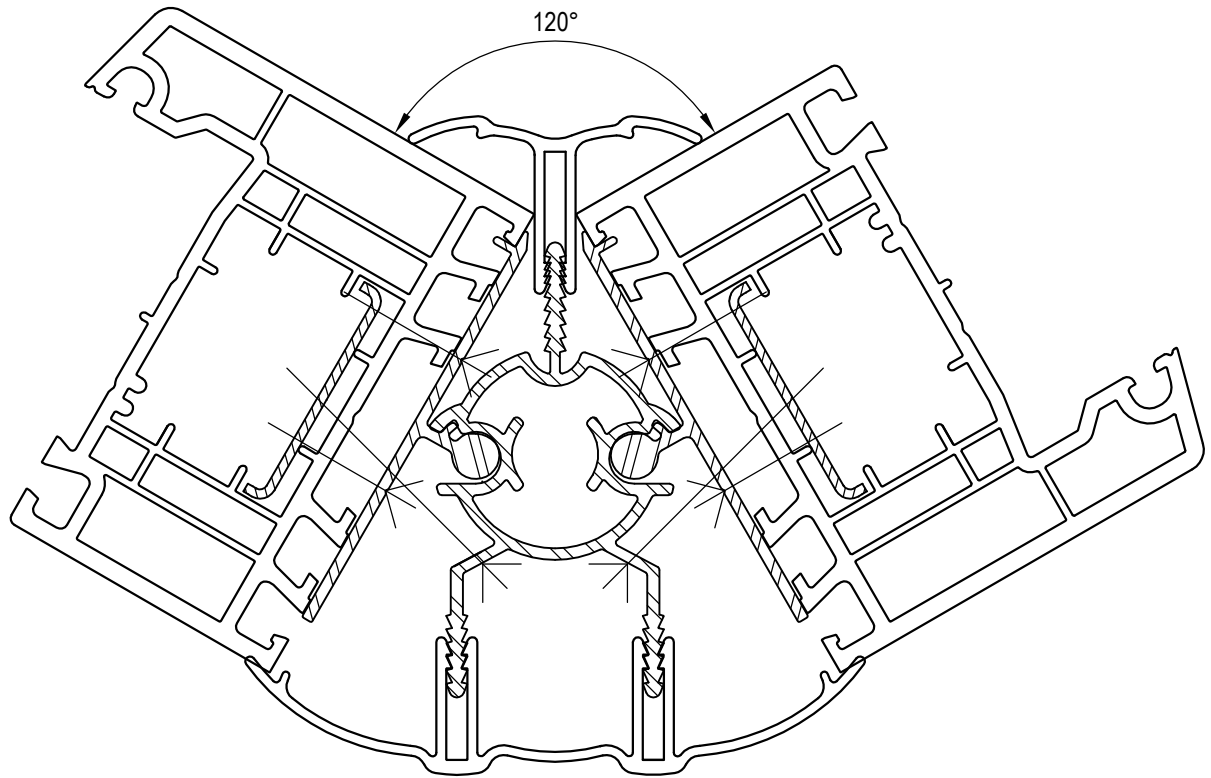

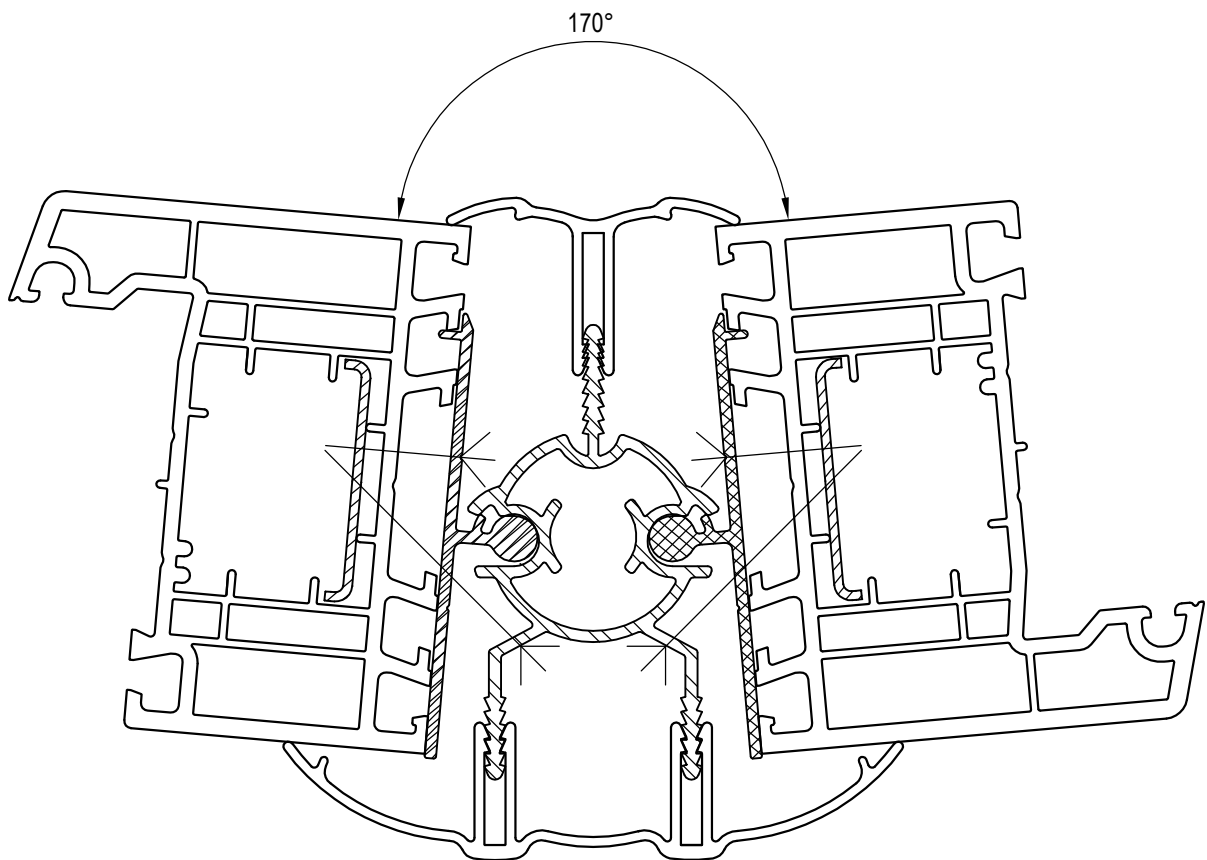
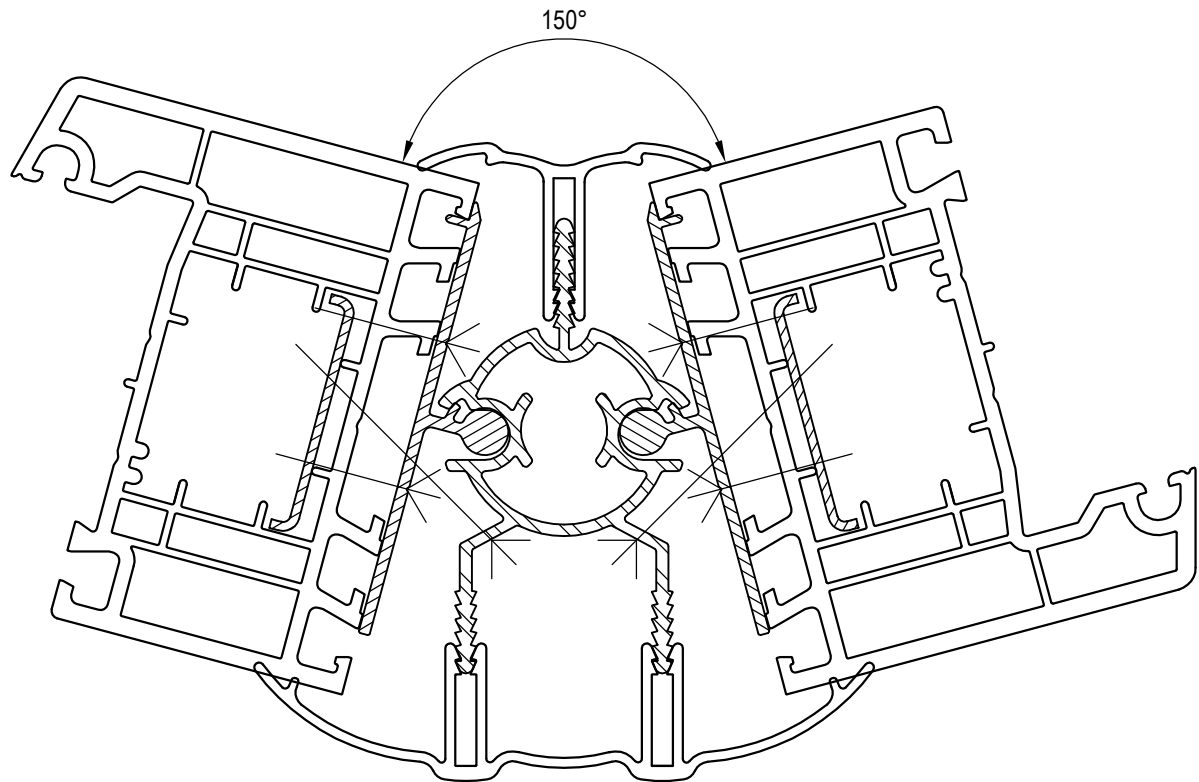

Note: Re-positioning of frame connector required for 153° - 170° angles

scale 1:1

04_L_01_4IDc_casem*

en May be subject to change and errors excepted!

Additional Profiles

Overview and Combinations
Bay window - Variable angle assembly details: 150° / 170°

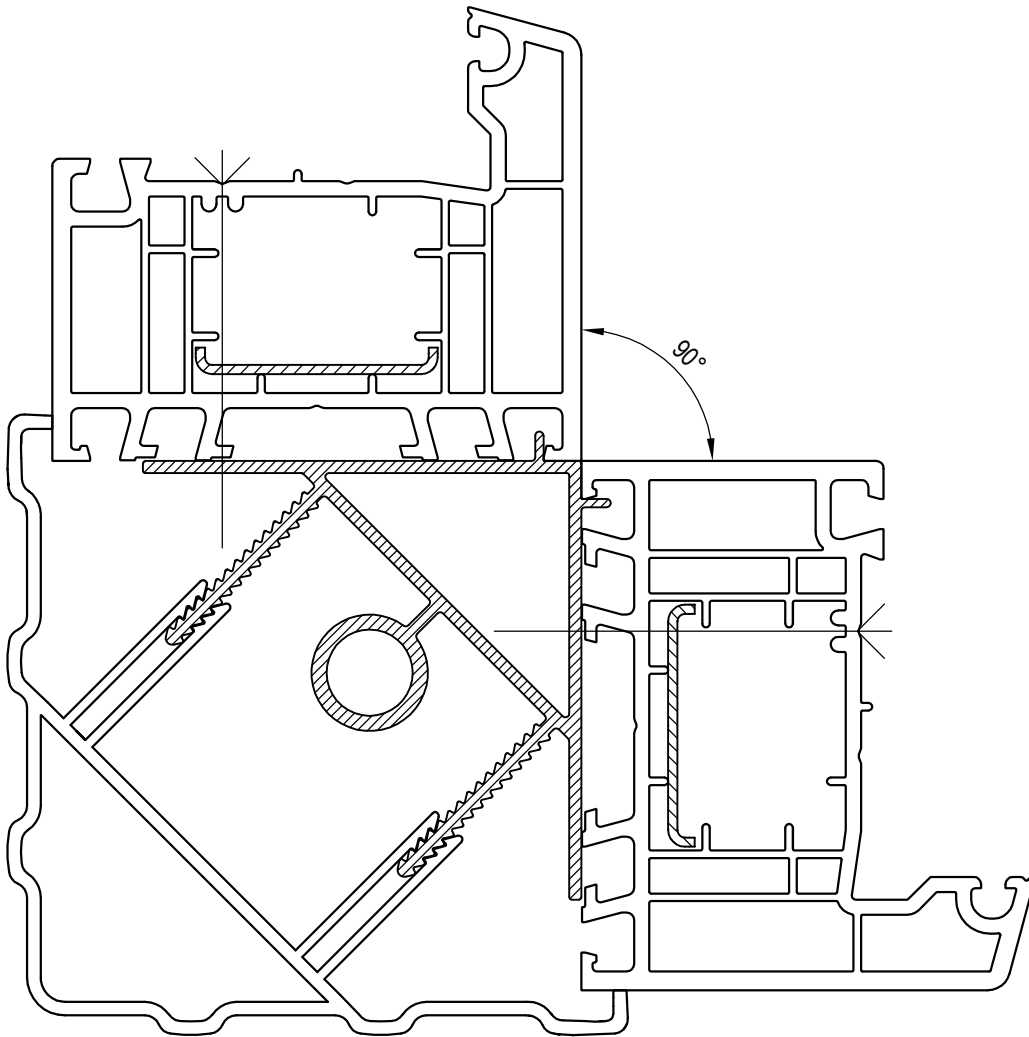

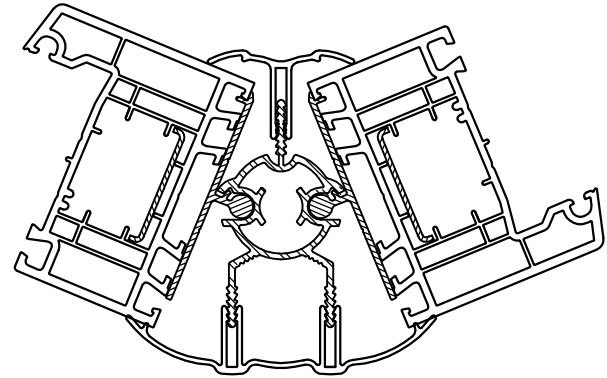
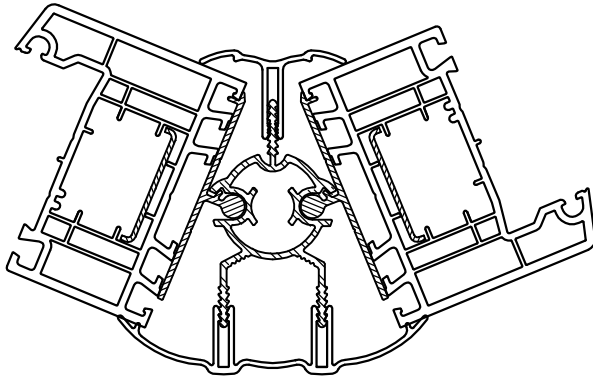

THE 'CILL' COLUMN RELATES TO A SURVEY POINT OF THE INSIDE CORNER OF A STANDARD HOLLOW CILL WITH A 2.5mm APPROX. WIDE INSIDE UPSTAND.

ANGLE () °	A=FRAME(mm)	B=CILL(mm)	ANGLE () °	A=FRAME(mm)	B=CILL(mm)
120	3.16	1.73	146	10.64	9.82
121	3.47	2.07	147	10.91	10.12
122	3.77	2.40	148	11.19	10.41
123	4.06	2.73	149	11.46	10.70
124	4.36	3.05	150	11.74	11.00
125	4.65	3.38	151	12.00	11.29
126	4.95	3.70	152	12.46	11.58
127	5.24	4.02	153	10.57	9.95
128	5.53	4.34	154	10.93	10.34
129	5.81	4.65	155	11.29	10.73
130	6.06	4.97	156	11.66	11.11
131	6.45	5.28	157	12.02	11.50
132	6.74	5.59	158	12.39	11.89
133	7.02	5.90	159	12.75	12.28
134	7.31	6.21	160	13.12	12.67
135	7.59	6.52	161	13.49	13.06
136	7.87	6.83	162	13.86	13.45
137	8.15	7.13	163	14.23	13.85
138	8.43	7.43	164	14.61	14.25
139	8.71	7.74	165	15.00	14.65
140	8.98	8.04	166	15.37	15.05
141	9.26	8.34	167	15.71	15.42
142	9.53	8.64	168	16.13	15.85
143	9.88	8.93	169	16.54	16.29
144	10.09	9.23	170	16.98	16.75
145	10.36	9.53			

RE-POSITIONING OF FRAME CONNECTOR
REQUIRED FOR ANGLES 153°-170° ON
OUTERFRAME (SEE PAGE 04 L 02)

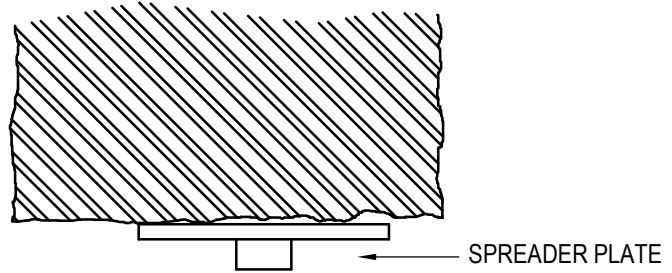
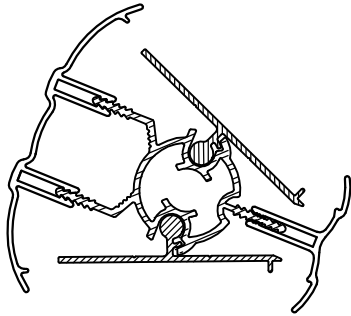

LOAD BEARING CALCULATIONS FOR
IDEAL 70 VARIABLE ANGLE
DECORATIVE BAY SYSTEM
AT HEIGHTS OF:-

1200mm = 2.7 TONNE (APPROX)
1500mm = 2.4 TONNE (APPROX)
1800mm = 2.1 TONNE (APPROX)

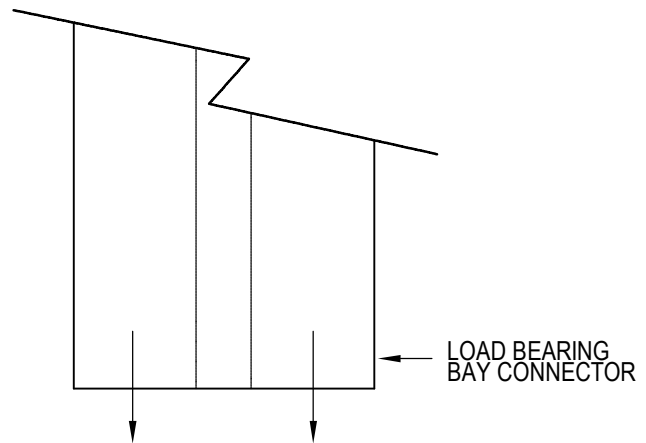

Load Bearing Capacity of Baypoles, Assumes the Following:

The Effective Length of a bay pole is determined by the type of fixings at its ends. If the pole is effectively held in position at both ends, but is not restrained in the centre, then the Effective Length equals the actual length of the pole.

If however, the Supplier can show that the bay-pole is restrained at the centre, for example by means of the adjacent windows, then the Effective Length is only 70% of the actual length of the bay pole.

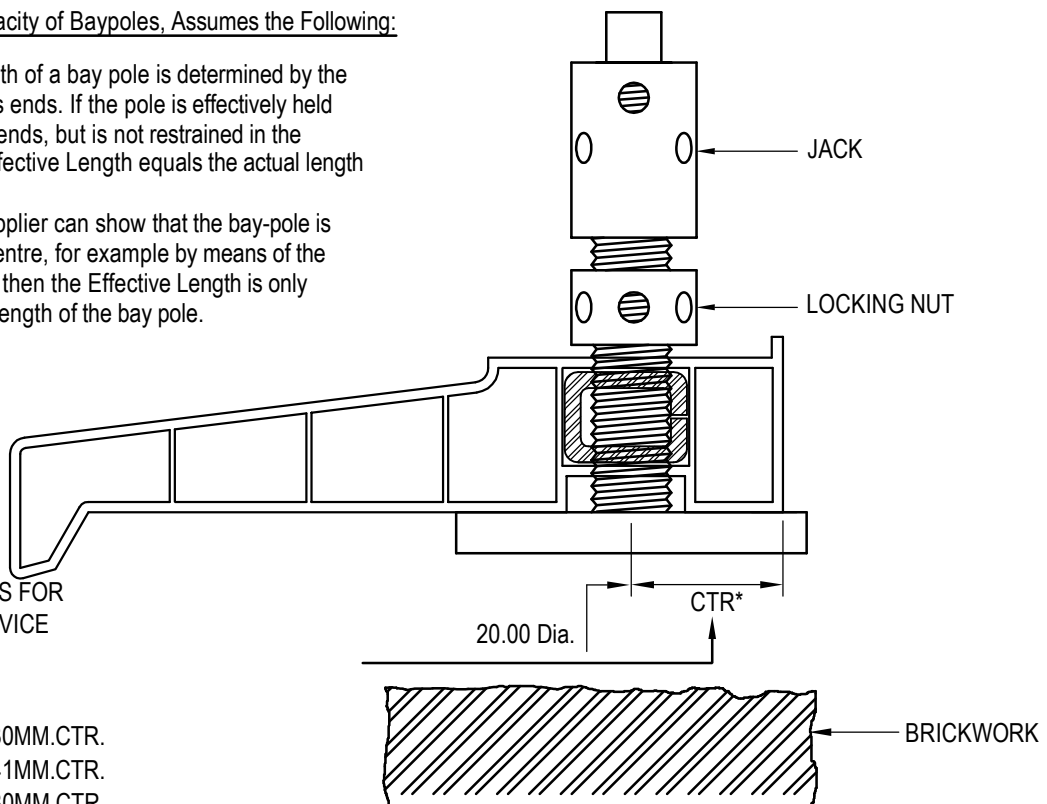

*NOTE:- HOLE CENTRES FOR
BAY POLE JACKING DEVICE

120° - 152° = 30MM.CTR.
153° - 170° = 41MM.CTR.
90° = 30MM.CTR.

Note: Variable angle and 90° Bay Connector Cutting Length
= Structural Opening Height Less 112mm.

Note: The Maximum Frame Height to be
= Structural Opening Height Less 12mm Minimum.

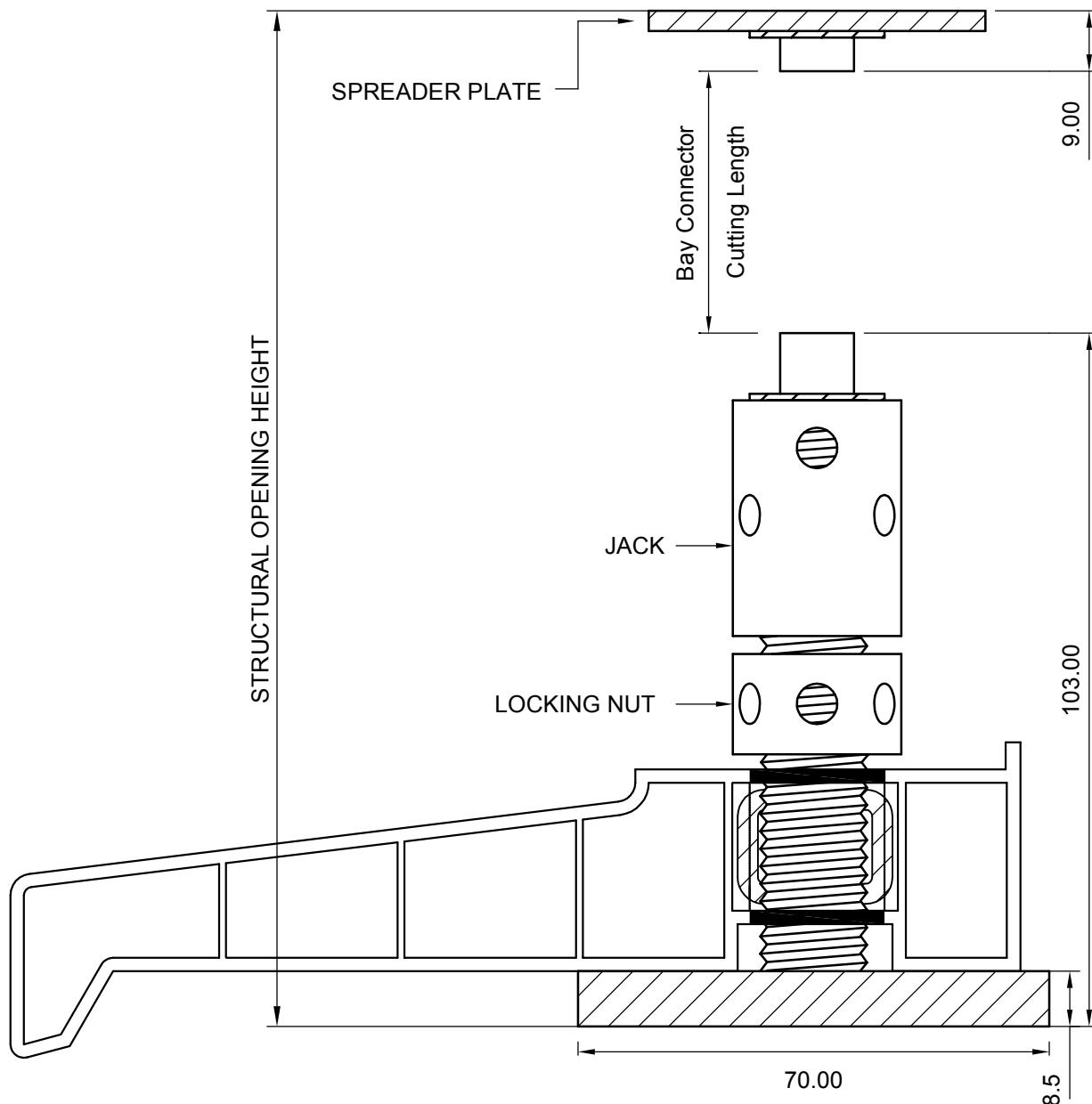

Assembly Instruction Flush Sash

- [1] Shorten the gasket [1a] / [1b].
- [2] Mill the sash contour -> [2a] / [2b]. Milling cutters / patterns upon request.
- [3] Cut the reinforcements [F], position them and fasten them with screws.
- [4] Pre-drill the connectors [D], insert them and fix them with screws [2a] + [2b] + [3a] + [3b].
- [5] Facing the sashes and screw them together with connectors.
- [6] Insert the end caps (glue/seal) and fix them with screws.

Profile series

IDEAL 4000 casement

Construction depth

70mm

Connector

Sash

DI 600150

-> 100x50

DI 600151

-> 100x51

FI Reinforcements

FI 229029, 229030

-> 100x50

FI 209051

-> 100x51

End cap

ICI 600051

Gasket

XI 409051

Screws

e.g.

(1) 16x 4.3x16mm SFS -> DI

(2) 4x 5x100mm Spax / Assy -> DI

(3) 8x 5x100mm Spax / Assy -> DI

(4) 1x 4.3x20mm SFS -> ICI

(5) ... 3.9x19mm EJOT FD21 -> FI

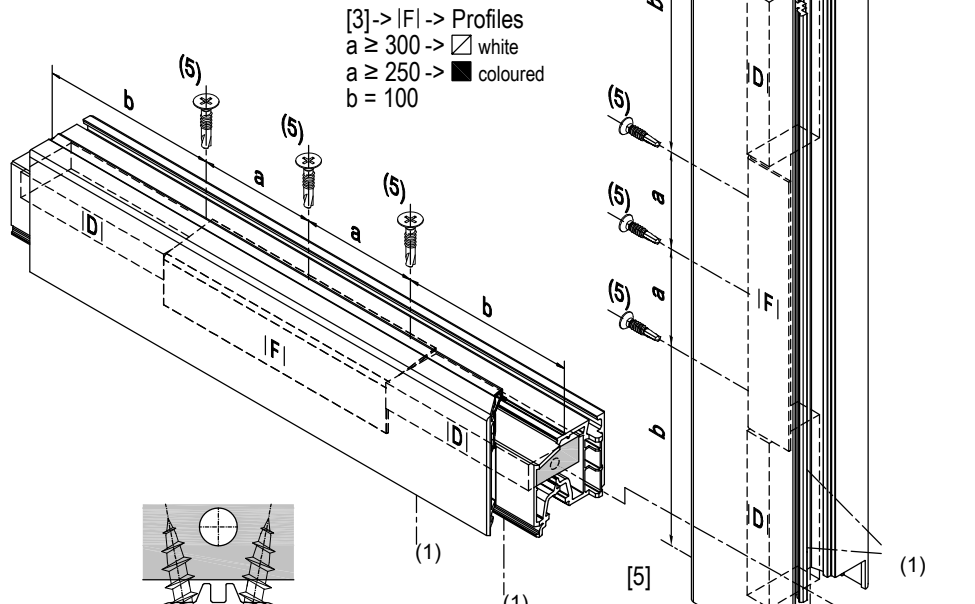
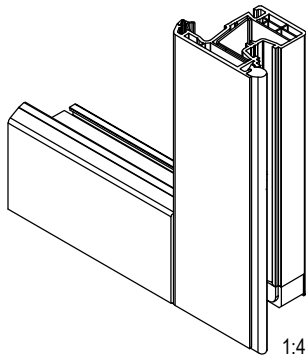
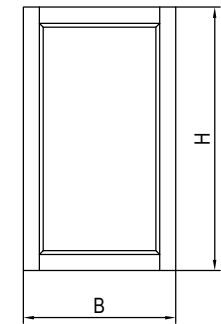
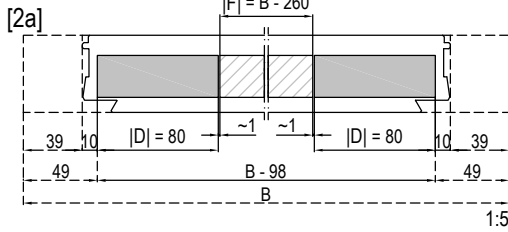
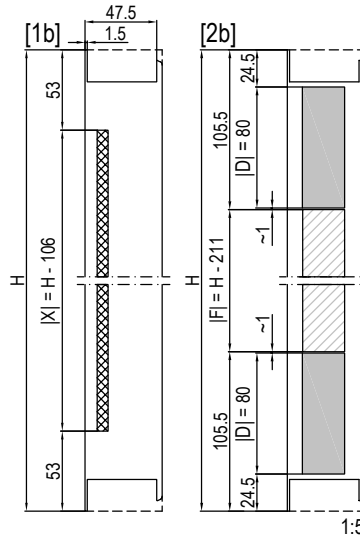
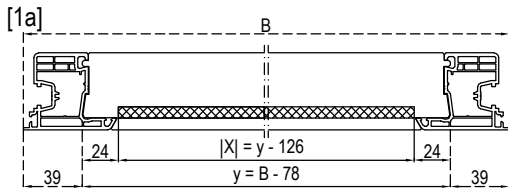

- [3]-> FI -> Profiles
 a >= 300 -> white
 a >= 250 -> coloured
 b = 100

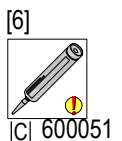
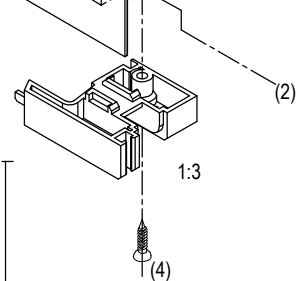
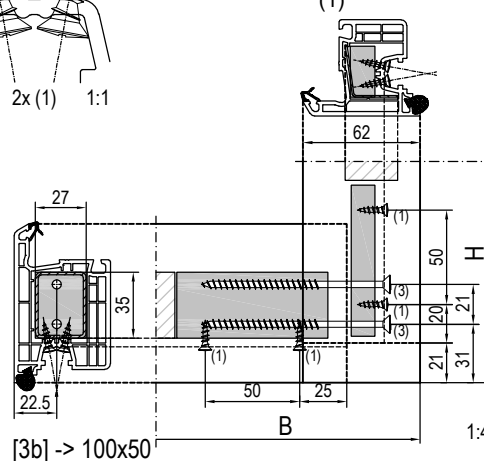
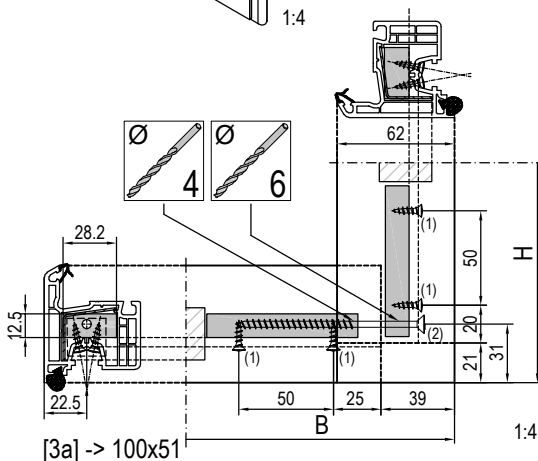
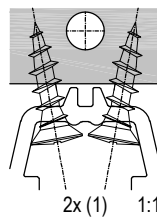

Scale 1:3, 1:4, 1:5

09_H_01_4IDc*

en May be subject to change and errors excepted!

Individual Handling

Butt-joined
 Mechanical Connections
 Sash 100x50, 100x51

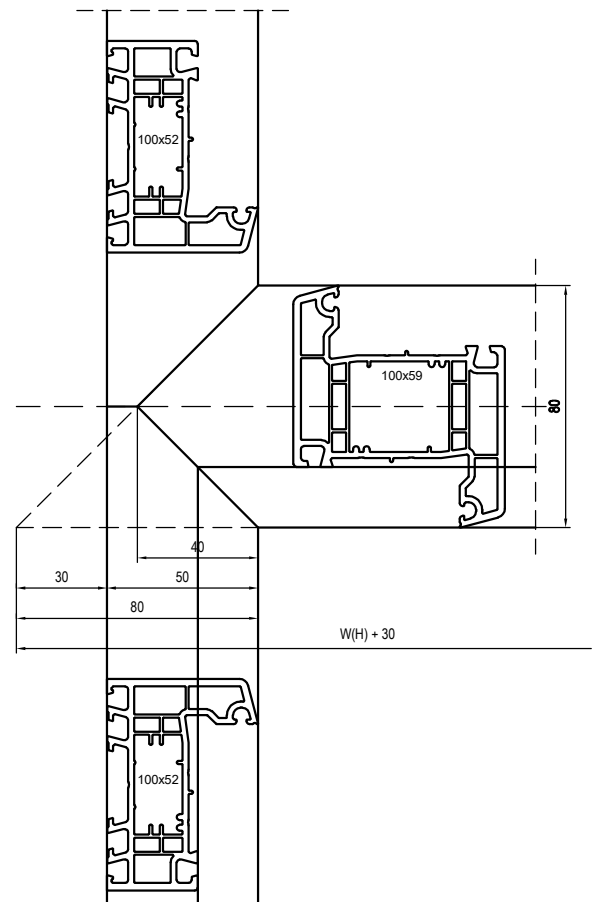
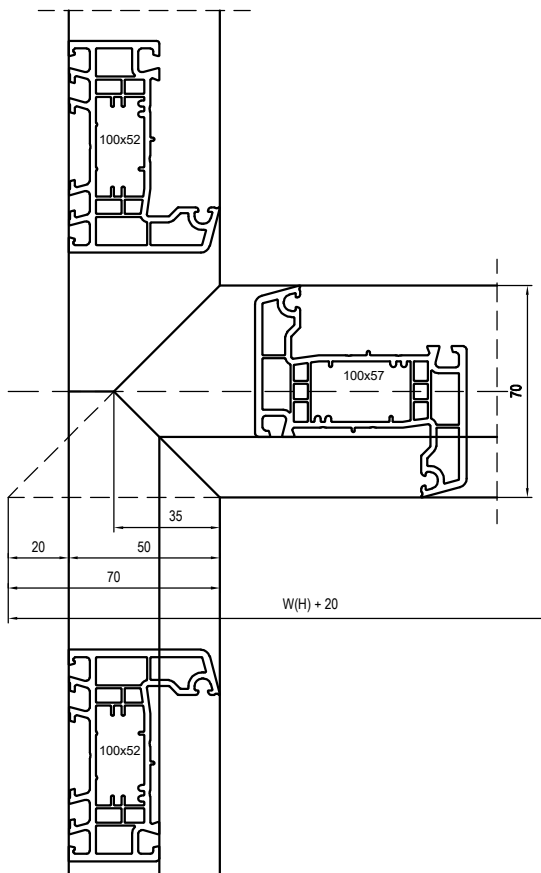
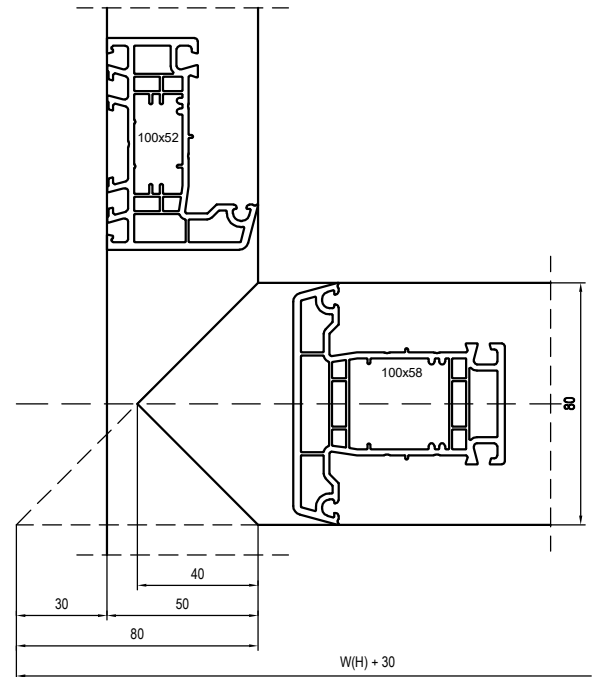
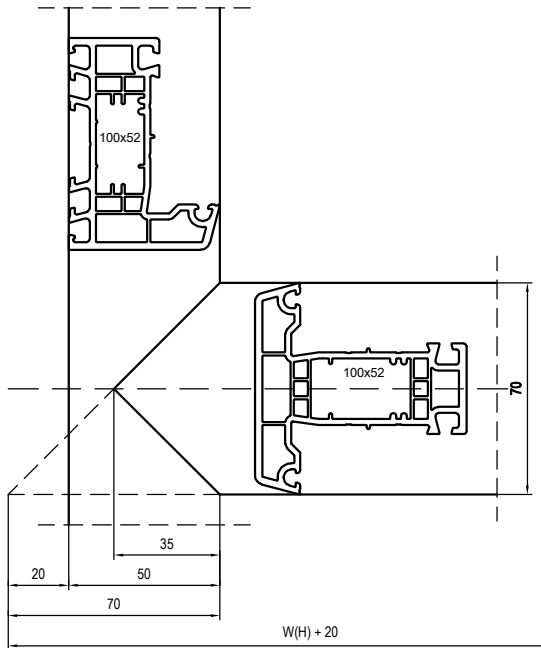

DATUM REFERENCE POINTS

CUTTING CALCULATION DETAILS SHOWING HOW THE TABLES ON THE FOLLOWING PAGES RELATE TO THE PROFILES:-

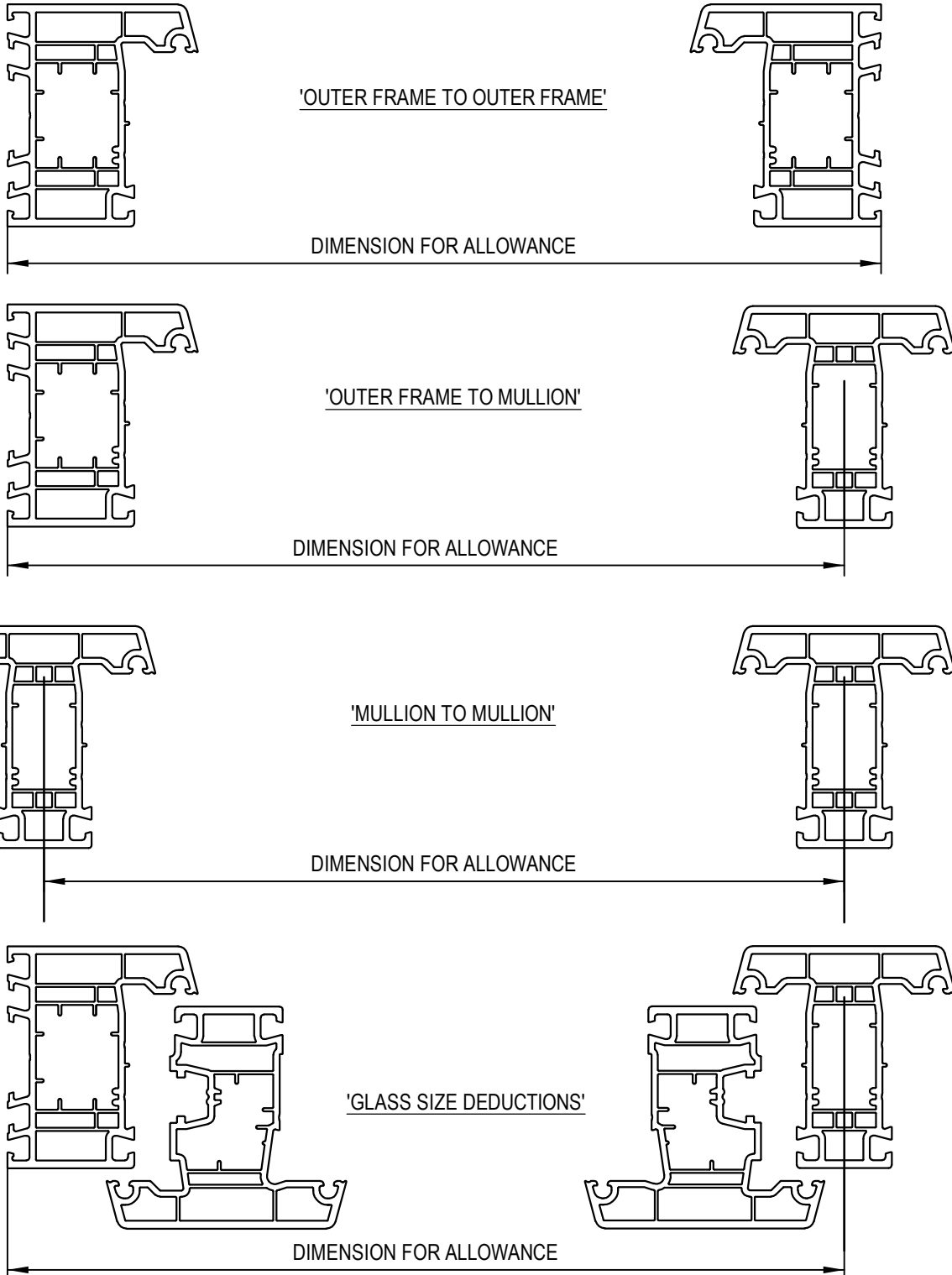

WELDING:- V NOTCH CUT DEPTHS

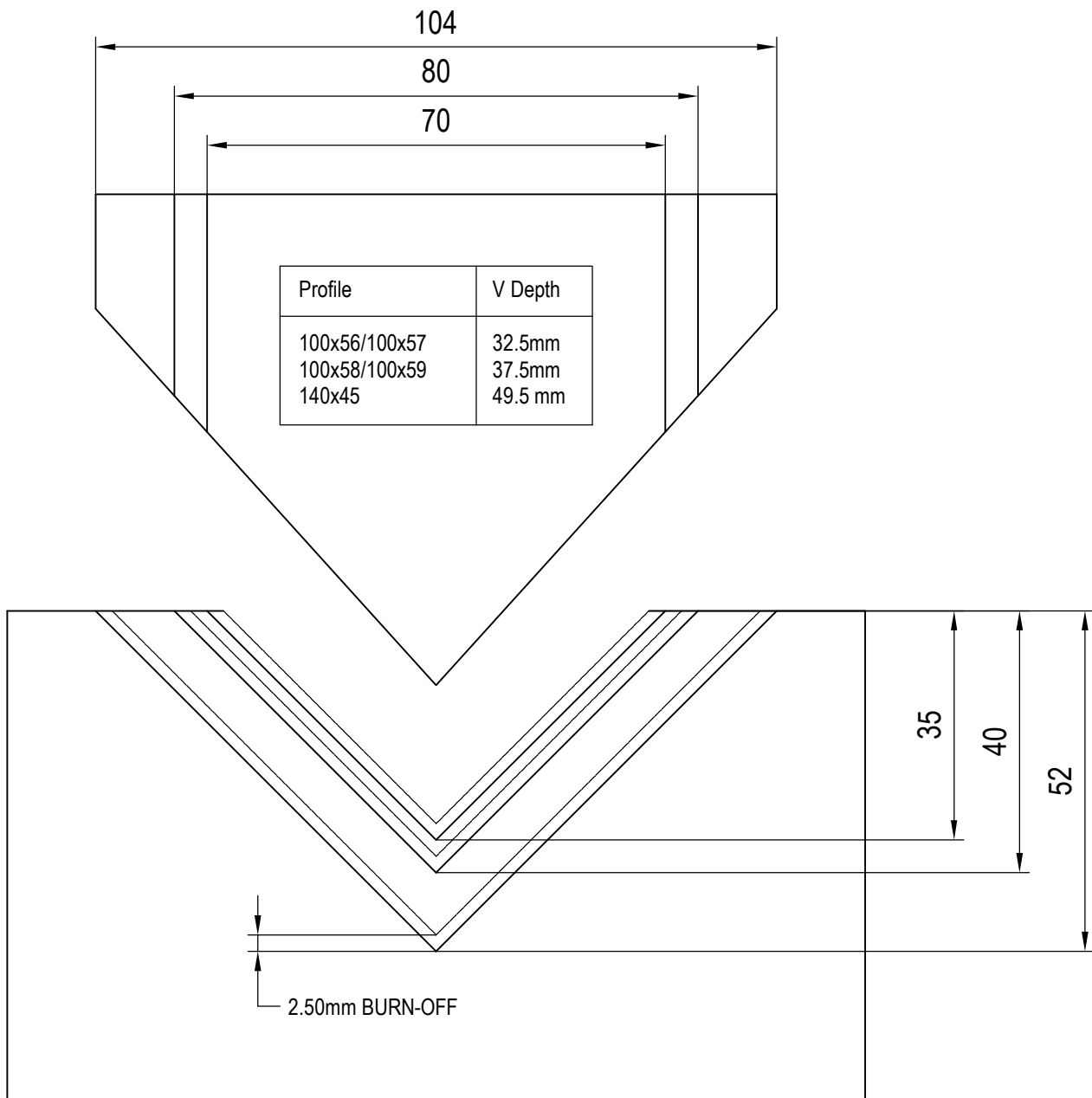

V CUT DEPTH IS EQUAL TO TRANSOM WIDTH DIVIDED BY 2, LESS THE WELD BURN-OFF. IE. $(70/2)-2.5 = 32.5\text{mm}$

The sizes shown are provided as guidance only allowing for a 2.5mm burn-off. Please take into consideration the actual burn-off. NB - Machine scale readings are often not true to the actual depth of the notch.

DIMENSIONS OF PROFILES & GLASS

CUTTING SIZES FOR WELDED MULLIONS & TRANSOMS:

BETWEEN SECTIONS	100x56/100x57	100x58/100x59
100x52-100x52	+40	+60
100x53-100x53	+20	+40
100x54-100x54	-10	+10
100x52-100x54	+15	+35
100x53-100x54	+5	+25
100x52-100x56/100x57	+55	+75
100x53-100x56/100x57	+45	+65
100x54-100x58/100x59	+30	+50
100x52-100x58/100x59	+50	+70
100x53-100x58/100x59	+40	+60
100x54-100x58/100x59	+25	+45
100x56/100x57-100x56/100x57	+70	+90
100x58/100x59-100x58/100x59	+60	+80
100x58/100x59-100x56/100x57	+65	+85

CUTTING SIZES FOR VENTS:

BETWEEN SECTIONS	100x55
100x52-100x52	-44
100x53-100x53	-64
100x54-100x54	-94
100x52-100x54	-69
100x53-100x54	-79
100x52-100x56/100x57	-29
100x53-100x56/100x57	-39
100x54-100x56/100x57	-54
100x52-100x58/100x59	-34
100x53-100x58/100x59	-44
100x54-100x58/100x59	-59
100x56/100x57-100x56/100x57	-14
100x58/100x59-100x58/100x59	-24
100x58/100x59-100x56/100x57	-19

GLASS SIZE DEDUCTIONS:

BETWEEN SECTIONS	FIXED	VENT
100x52-100x52	-70	-165
100x53-100x53	-90	-185
100x54-100x54	-120	-215
100x52-100x54	-95	-190
100x53-100x54	-105	-200
100x52-100x56/100x57	-55	-150
100x53-100x56/100x57	-65	-160
100x54-100x56/100x57	-80	-175
100x52-100x58/100x59	-60	-155
100x53-100x58/100x59	-70	-165
100x54-100x58/100x59	-85	-180
100x56/100x57-100x56/100x57	-40	-135
100x58/100x59-100x58/100x59	-50	-145
100x58/100x59-100x56/100x57	-45	-140

DUMMY TRANSOM/MULLION DEDUCTIONS :

BETWEEN SECTIONS	CUTTING SIZES	GLASS DEDUCTION
	100x56/100x57	100x56/100x57
100x52-100x52	-55	-205
100x53-100x53	-75	-225
100x54-100x54	-105	-255
100x52-100x54	-80	-230
100x53-100x54	-90	-240
100x52-100x56/100x57	-40	-190
100x53-100x56/100x57	-50	-200
100x54-100x56/100x57	-65	-215
100x52-100x58/100x59	-45	-195
100x53-100x58/100x59	-55	-205
100x54-100x58/100x59	-70	-220
100x56/100x57-100x56/100x57	-25	-175
100x58/100x59-100x58/100x59	-35	-185
100x58/100x59-100x56/100x57	-30	-180

NOTE: All cutting calculations are based on weld allowances not being included.
Variations may also be experienced due to different weld burn-offs etc.

DIMENSIONS OF PROFILES & GLASS

TYPICAL CASEMENT WINDOW

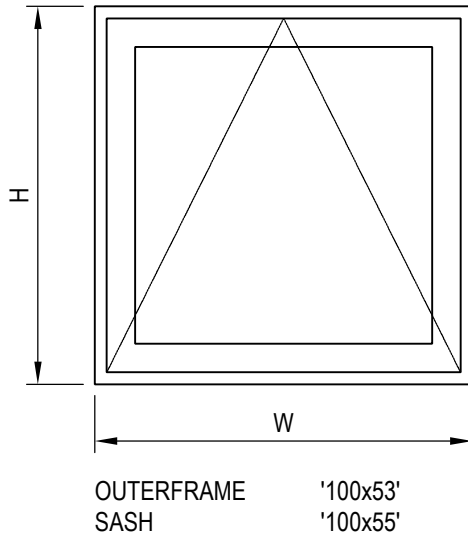

PROFILE CUTTING CALCULATIONS

Qty	Bar	Calc	End Prep
2No	100x53	W+0	MITRE/MITRE
2No	100x53	H+0	MITRE/MITRE
2No	100x55	W-64	MITRE/MITRE
2No	100x55	H-64	MITRE/MITRE

GENERAL REINFORCEMENT CRITERIOR

Section	White Profile	W/G Profile
O/Frame Head	Over 1350mm	All Members
O/Frame	Over 1500mm	All Members
Sash	Over 600mm	All Members

GLASS SIZES

Sash	Width	Height
1No	W - 185	H - 185

Note: - All cutting calculations are based on weld allowances not being included. Variations may also be experienced due to different weld burn-offs etc. Refer to Manufacturers Guide for general reinforcement specifications and recommendations.

TYPICAL CASEMENT MULTI-LITE WINDOW

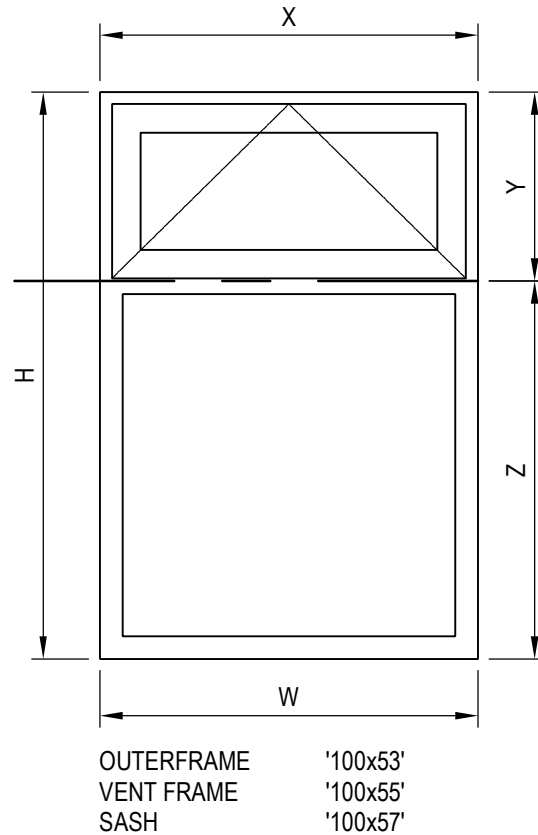

PROFILE CUTTING CALCULATIONS

Qty	Bar	Calc	End Prep
2No	100x53	W+0	MITRE/MITRE
2No	100x53	H+0	MITRE/MITRE
2No	100x55	X-64	MITRE/MITRE
2No	100x55	Y-39	MITRE/MITRE
1No	100x57	W+20	MITRE/MITRE

GENERAL REINFORCEMENT CRITERIOR

Section	White Profile	W/G Profile
O/Frame Head	Over 1350mm	All Members
O/Frame	Over 1500mm	All Members
Sash	Over 600mm	All Members
Trans/Mullion	Over 700mm	All Members

GLASS SIZES

	Width	Height
1No	X - 185	Y - 160
1No	W - 90	Z - 65

DATUM REFERENCE POINTS

CUTTING CALCULATION DETAILS SHOWING HOW THE TABLES ON THE FOLLOWING PAGES RELATE TO THE PROFILES:

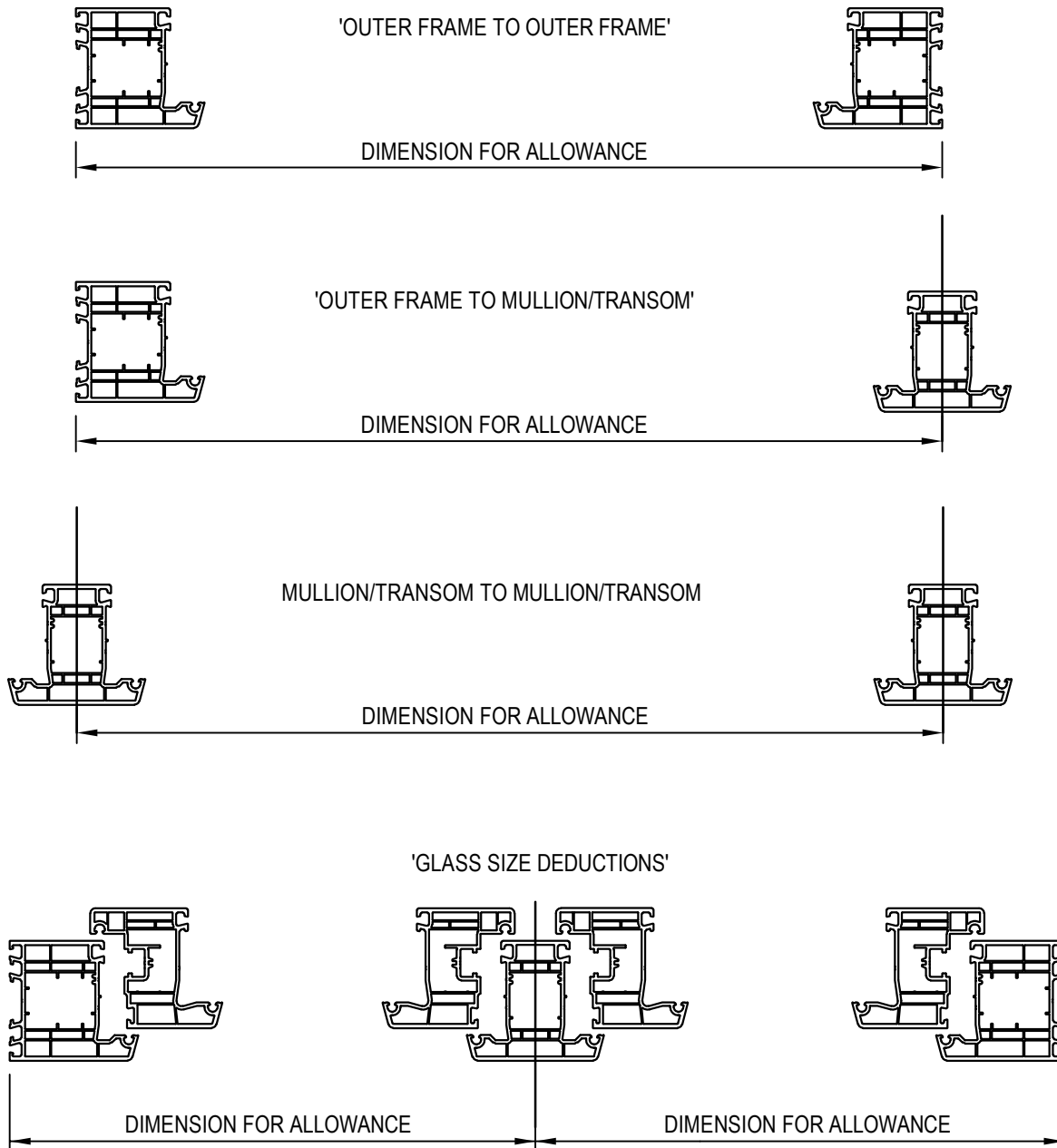

WELDING:- V NOTCH CUT DEPTHS

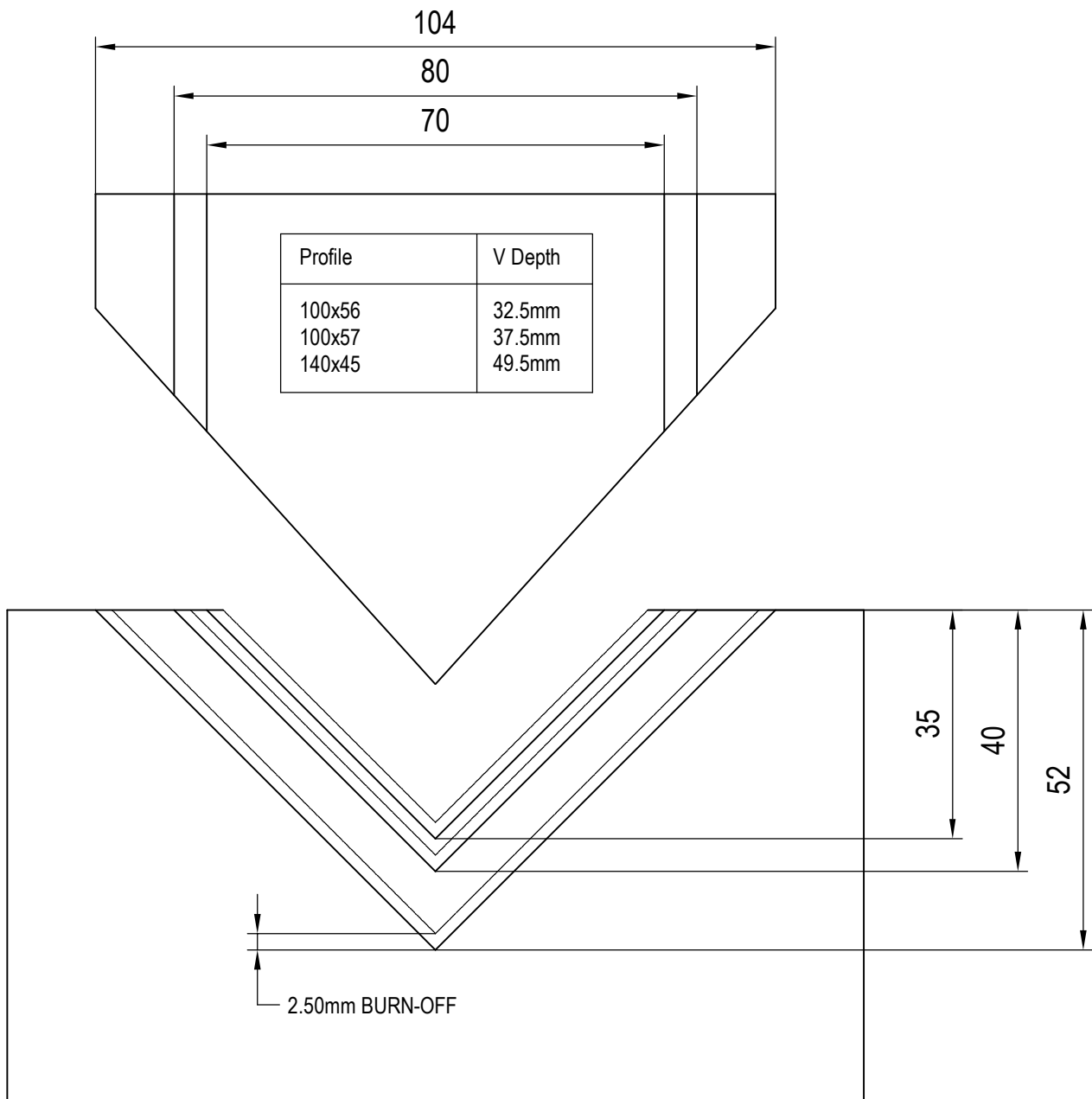

V CUT DEPTH IS EQUAL TO TRANSOM WIDTH DIVIDED BY 2, LESS THE WELD BURN-OFF. IE. $(70/2)-2.5 = 32.5\text{mm}$

The sizes shown are provided as guidance only allowing for a 2.5mm burn-off. Please take into consideration the actual burn-off. NB - Machine scale readings are often not true to the actual depth of the notch.

DIMENSIONS OF PROFILES & GLASS

CUTTING SIZES FOR WELDED MULLIONS/TRANSOMS & VENT SECTIONS

GLASS SIZE DEDUCTIONS

BETWEEN SECTIONS	TRANSOM/MULLION		VENT SECTION
	100x58	140x45	140x20
100x53-100x53	+40	+88	-64
100x54-100x54	+10	+58	-94
100x53-100x54	+25	+73	-79
100x53-100x58	+60	+108	-44
100x54-100x58	+45	+93	-59
100x53-140x45	+48	+96	-56
100x54-140x45	+33	+81	-71
100x58-100x58	+80	+128	-24
140x45-140x45	+45	+104	-48
100x58-140x45	+68	+116	-36

BETWEEN SECTIONS	Fixed Lite	Vent Section
100x53-100x53	-90	-188
100x54-100x54	-120	-218
100x53-100x54	-105	-203
100x53-100x58	-70	-168
100x54-100x58	-85	-183
100x53-140x45	-82	-180
100x54-140x45	-97	-195
100x58-100x58	-50	-148
140x45-140x45	-74	-172
100x58-140x45	-62	-160

CUTTING SIZES FOR WELDED DUMMY BARS IN 140x20 VENT.

GLASS SIZE DEDUCTIONS FOR DUMMY BARS IN VENTS.

BETWEEN SECTIONS	TRANS/MULL	
	100x56	100x58
100x53-100x53	-78	-58
100x54-100x54	-108	-88
100x53-100x54	-93	-73
100x53-100x58	-58	-38
100x54-100x58	-73	-53
100x53-140x45	-70	-50
100x54-140x45	-85	-65
100x58-100x58	-38	-18
140x45-140x45	-62	-42
100x58-140x45	-50	-30

BETWEEN SECTIONS	VENT SECTION	
	100x56	100x58
100x53-100x53	-228	-238
100x54-100x54	-258	-268
100x53-100x54	-243	-253
100x53-100x58	-208	-218
100x54-100x58	-223	-233
100x53-140x45	-220	-230
100x54-140x45	-235	-245
100x58-100x58	-188	-198
140x45-140x45	-212	-222
100x58-140x45	-200	-210

Note: All cutting Calculations are based on: Weld Allowance Not Included.
Variations may be experienced due to different weld burn-offs etc.,

DIMENSIONS OF PROFILES & GLASS:

TYPICAL TILT & TURN WINDOW

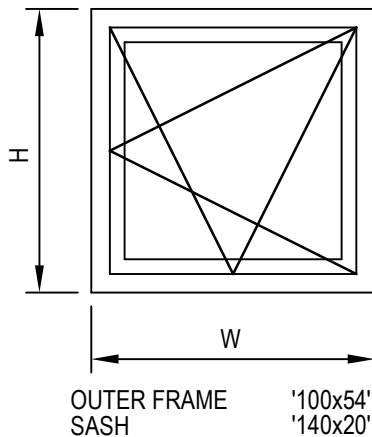

PROFILE CUTTING CALCULATIONS

Qty.	Bar.	Calc.	End Prep.
2No.	100x54	W+5	Mitre/Mitre
2No.	100x54	H+5	Mitre/Mitre
2No.	140x20	W-94	Mitre/Mitre
2No.	140x20	H-94	Mitre/Mitre

REINFORCEMENT REQUIREMENTS

Reinforcement	White Profile	Woodgrain Profile
Outer Frame Head Sash	Over 1350 Widths & Heights Over 800. (provided a locking point is in situ), otherwise 600mm	All Members

GLASS SIZES:		Width	Height
Sash	1No.	w -218	h -218

Note: - All cutting calculations are based on weld allowances not being included. Variations may also be experienced due to different weld burn-offs etc. Refer to Manufacturers Guide (book 01:01:00) for general reinforcement specifications and recommendations.

TYPICAL TILT & TURN MULTI-LITE WINDOW

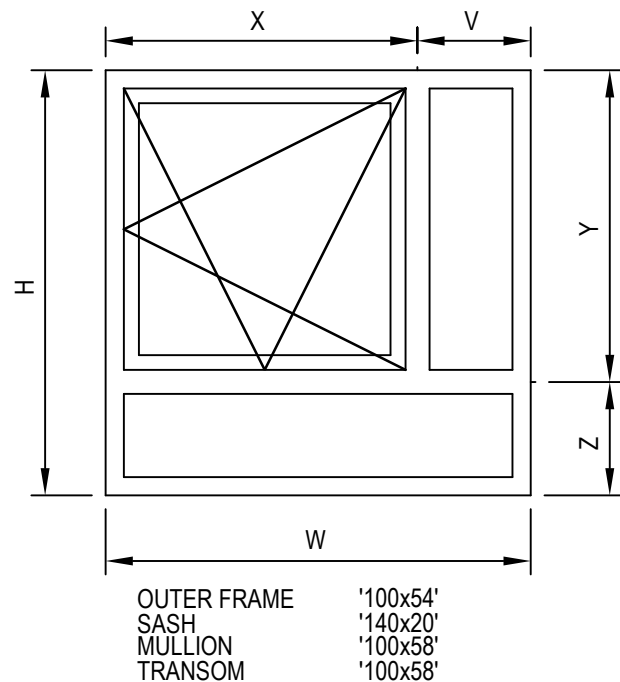

PROFILE CUTTING CALCULATIONS

Qty.	Bar.	Calc.	End Prep.
2No.	100x54	W+5	Mitre/Mitre
2No.	100x54	W+5	Mitre/Mitre
2No.	140x20	X-59	Mitre/Mitre
2No.	140x20	Y-59	Mitre/Mitre
1No.	100x58	W+10	Mitre/Mitre
1No.	100x58	Y+45	Mitre/Mitre

REINFORCEMENT REQUIREMENTS

Reinforcement	White Profile	Woodgrain Profile
Outer Frame	Over 1500	All Members
Outer Frame Head	Over 1350	
Transom	Over 700	
Mullion	Over 700	
Sash	Widths & Heights Over 800. (provided a locking point is in situ), otherwise 600mm	

GLASS SIZES:		Width	Height
Sash:	1No.	x -183	y -183
Fixed Lite:	1No.	v -85	y -85
Fixed Lite:	1No.	w -120	z -85

DATUM REFERENCE POINTS

CUTTING CALCULATION DETAILS SHOWING HOW THE TABLES ON THE FOLLOWING PAGES RELATE TO THE PROFILES:

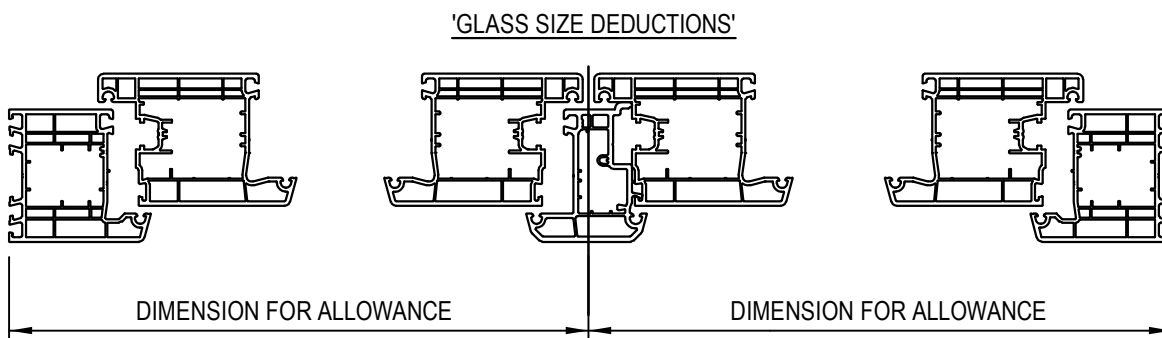
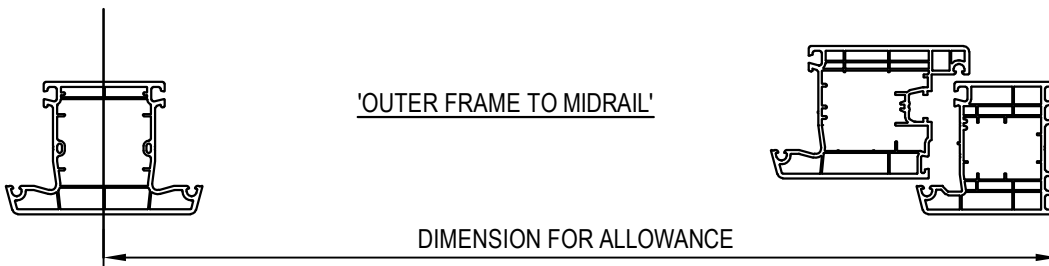
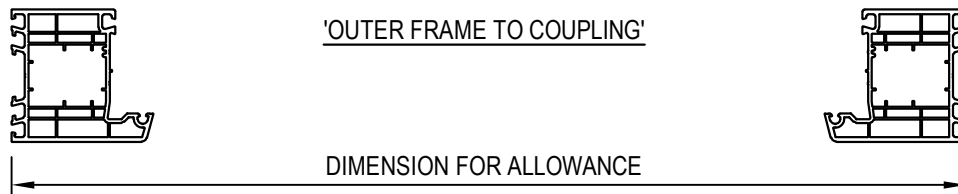
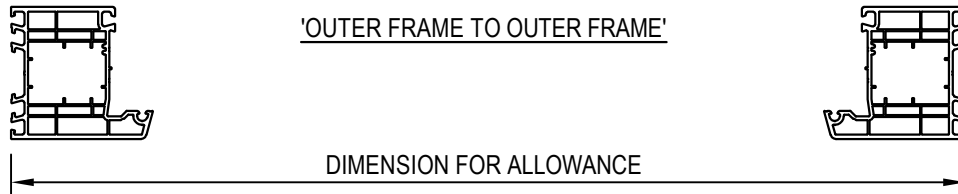

WELDING:- V NOTCH CUT DEPTHS

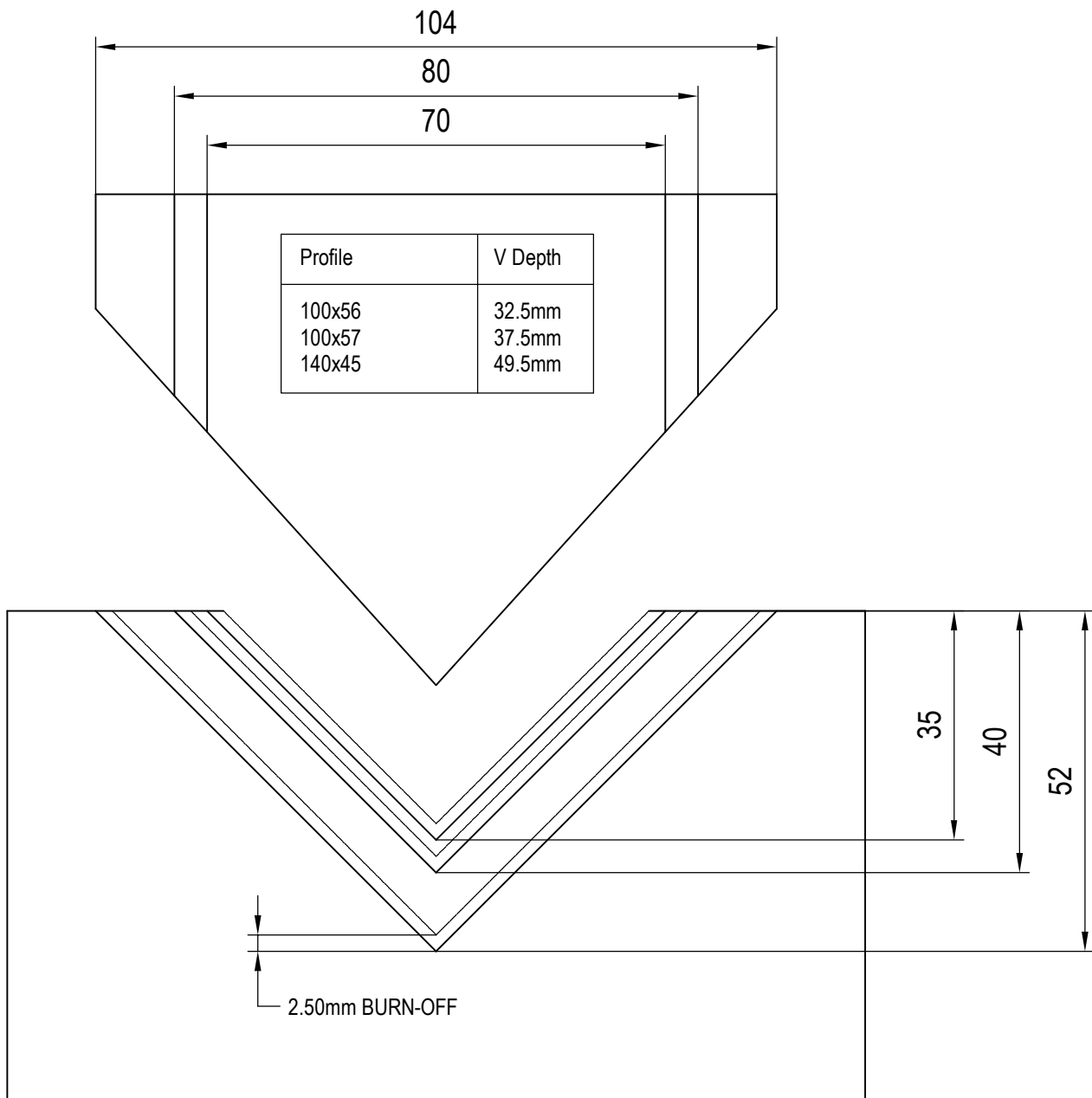

V CUT DEPTH IS EQUAL TO TRANSOM WIDTH DIVIDED BY 2, LESS THE WELD BURN-OFF. IE. $(70/2)-2.5 = 32.5\text{mm}$

The sizes shown are provided as guidance only allowing for a 2.5mm burn-off. Please take into consideration the actual burn-off. NB - Machine scale readings are often not true to the actual depth of the notch.

DIMENSIONS OF PROFILES & GLASS

CUTTING SIZES FOR VENTS, FALSE MULLION & MIDRAILS

	VENT	FALSE MULLION
BETWEEN SECTIONS	140x30	140x67
100x53-100x52	-54	-138
100x53-100x53	-64	-148
100x54-100x52	-69	-153
100x54-100x53	-79	-163
100x54-100x54	-94	-178
100x52-140x67	-26	—
100x53-140x67	-36	—
100x54-140x67	-51	—
—	—	—
—	—	—
—	—	—
—	—	—

GLASS SIZE DEDUCTIONS:

BETWEEN SECTIONS	Fixed Lite	Vent Section
100x53-100x52	-80	-234
100x53-100x53	-90	-244
100x54-100x52	-95	-249
100x54-100x53	-105	-259
100x54-100x54	-120	-274
100x54-140x67	—	-231
100x53-140x67	—	-216
100x54-100x58	-85	-162
100x54-140x45	-97	-174
100x53-100x58	-70	-147
100x53-140x45	-82	-159
100x52-100x58	-60	-137
100x52-140x45	-72	149
—	—	—
—	—	—
—	—	—
—	—	—
—	—	—
—	—	—
—	—	—
—	—	—

Note: All cutting Calculations are based on: Weld Allowance Not Included.
Variations may be experienced due to different weld burn-offs etc.

DIMENSIONS OF PROFILES & GLASS

TYPICAL RESIDENTIAL DOOR

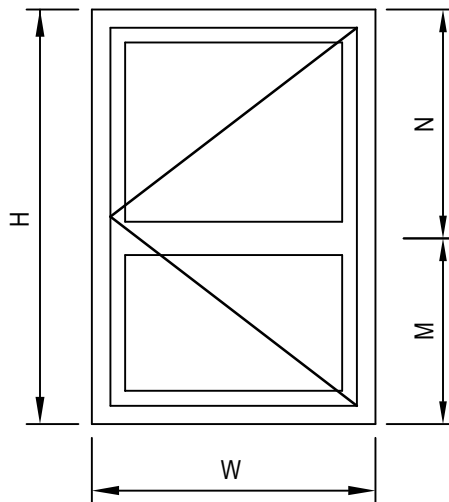

OUTER FRAME '100x54'
SASH '140x30'
MID RAIL '140x45'

TYPICAL FRENCH DOOR

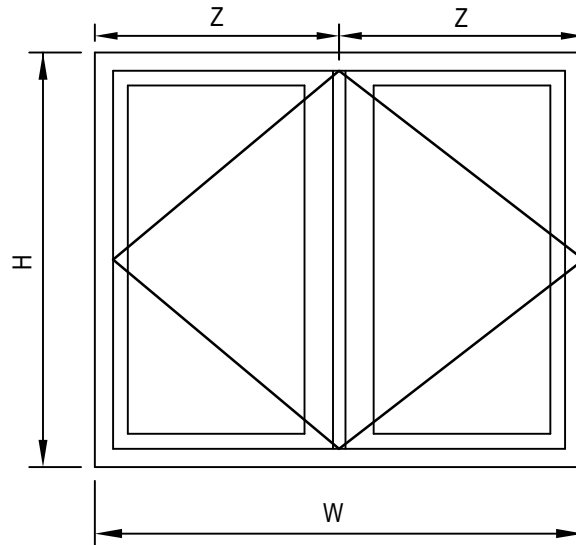

OUTER FRAME '100x54'
SASH '140x30'
FLY MULLION '140x67'

PROFILE CUTTING CALCULATIONS

Qty.	Bar.	Calc.	End Prep.
2No.	100x54	W+0	Mitre/Mitre
2No.	100x54	H+0	Mitre/Mitre
2No.	140x30	W-94	Mitre/Mitre
2No.	140x30	H-94	Mitre/Mitre
1No.	140x45	W-96	Mitre/Mitre

PROFILE CUTTING CALCULATIONS

Qty.	Bar.	Calc.	End Prep.
2No.	100x54	W+0	Mitre/Mitre
2No.	100x54	H+0	Mitre/Mitre
4No.	140x30	Z-51	Mitre/Mitre
4No.	140x30	H-94	Mitre/Mitre
1No.	140x67	H-178	Straight

GLASS SIZES:		Width	Height
Sash:	1No	W-274	N-179.5
	1No	W-274	M-179.5

GLASS SIZES:		Width	Height
Sash:	2No	Z-230	H-274

Note: All cutting Calculations are based on: Weld Allowance Not Included.
Variations may be experienced due to different weld burn-offs etc.

Note: Refer to Manufacturers Guide for general reinforcement specifications and recommendations.

DATUM REFERENCE POINTS

CUTTING CALCULATION DETAILS SHOWING HOW THE TABLES ON THE FOLLOWING PAGES RELATE TO THE PROFILES:

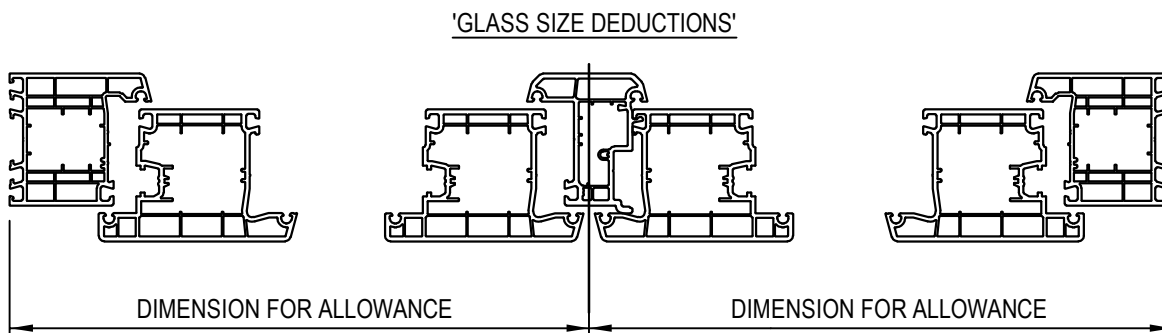
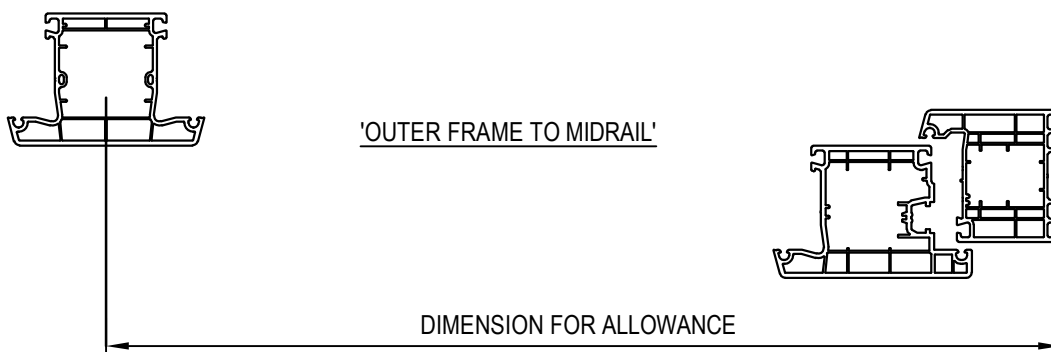
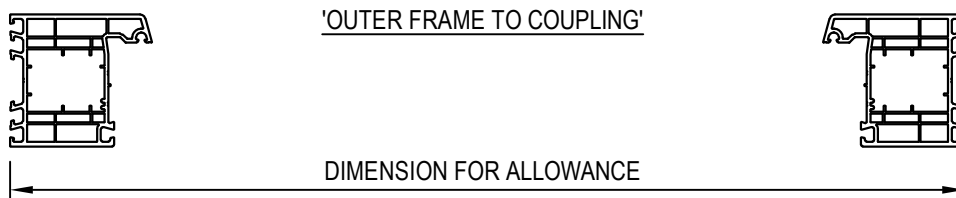
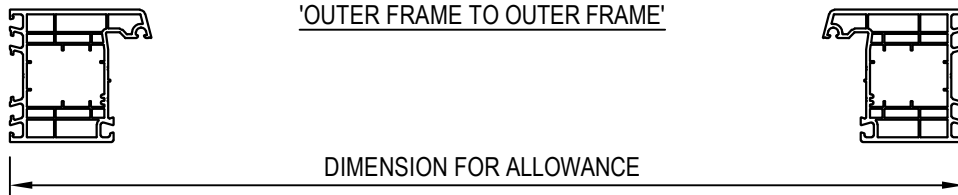

WELDING: V NOTCH CUT DEPTHS

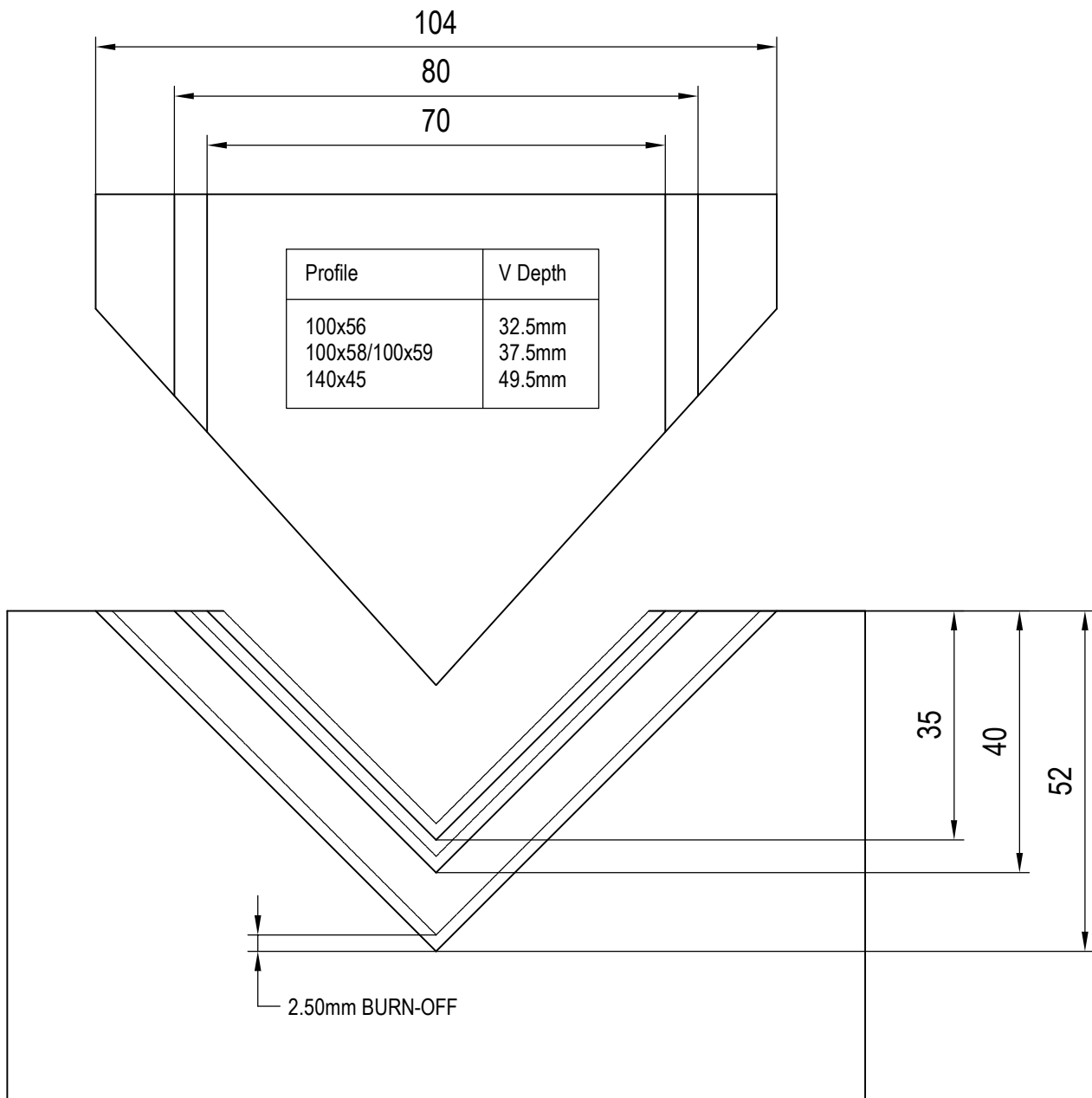

V CUT DEPTH IS EQUAL TO TRANSOM WIDTH DIVIDED BY 2, LESS THE WELD BURN-OFF. IE. $(70/2)-2.5 = 32.5\text{mm}$

The sizes shown are provided as guidance only allowing for a 2.5mm burn-off. Please take into consideration the actual burn-off. NB - Machine scale readings are often not true to the actual depth of the notch.

DIMENSIONS OF PROFILES & GLASS

CUTTING SIZES FOR VENTS, FALSE MULLION & MIDRAILS

	VENT	FLY MULLION
BETWEEN SECTIONS	140x31	140x67
100x53-100x52	-54	-138
100x53-100x53	-64	-148
100x54-100x52	-69	-153
100x54-100x53	-79	-163
100x54-100x54	-94	-178
100x52-140x67	-26	—
100x53-140x67	-36	—
100x54-140x67	-51	—
—	—	—
—	—	—
—	—	—
—	—	—

GLASS SIZE DEDUCTIONS:

BETWEEN SECTIONS	Fixed Lite	Vent Section
100x53-100x52	-80	-234
100x53-100x53	-90	-244
100x54-100x52	-95	-249
100x54-100x53	-105	-259
100x54-100x54	-120	-274
100x54-140x67	—	-231
100x53-140x67	—	-216
100x54-100x58	-85	-162
100x54-140x45	-97	-174
100x53-100x58	-70	-147
100x53-140x45	-82	-159
100x52-100x58	-60	-137
100x52-140x45	-72	-149
—	—	—
—	—	—
—	—	—
—	—	—
—	—	—
—	—	—
—	—	—
—	—	—

Note: All cutting Calculations are based on: Weld Allowance Not Included.
Variations may be experienced due to different weld burn-offs etc.

DIMENSIONS OF PROFILES & GLASS

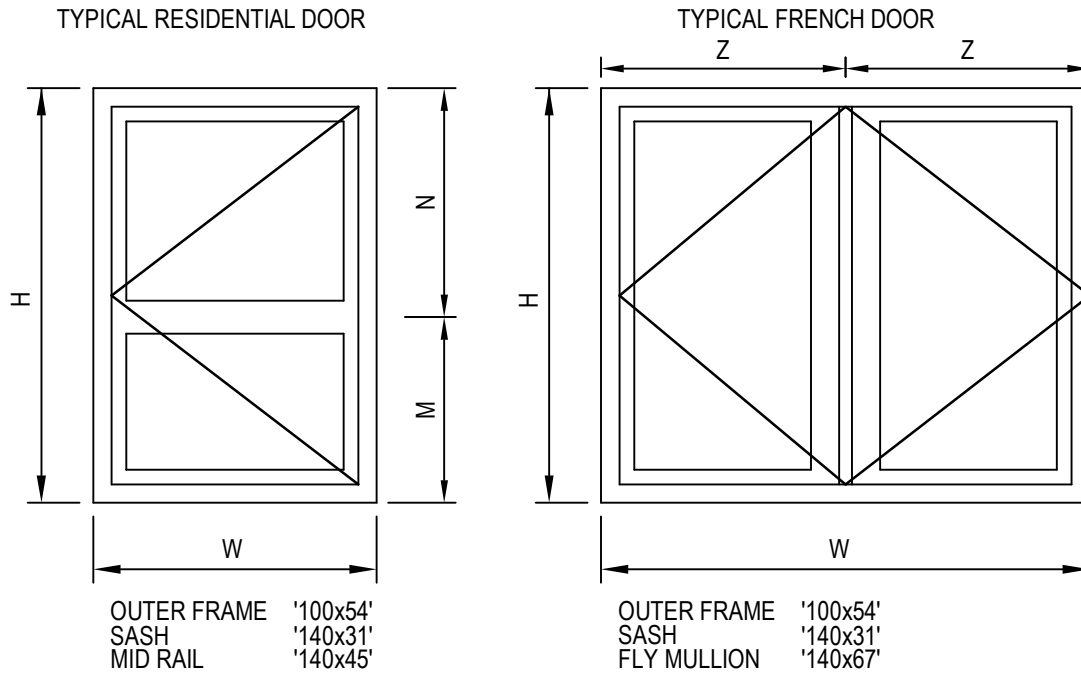

PROFILE CUTTING CALCULATIONS

Qty.	Bar.	Calc.	End Prep.
2No.	100x54	W+0	Mitre/Mitre
2No.	100x54	H+0	Mitre/Mitre
2No.	140x31	W-94	Mitre/Mitre
2No.	140x31	H-94	Mitre/Mitre
1No.	140x45	W-96	Mitre/Mitre

PROFILE CUTTING CALCULATIONS

Qty.	Bar.	Calc.	End Prep.
2No.	100x54	W+0	Mitre/Mitre
2No.	100x54	H+0	Mitre/Mitre
4No.	140x31	Z-51	Mitre/Mitre
4No.	140x31	H-94	Mitre/Mitre
1No.	140x67	H-178	Straight

GLASS SIZES:		Width	Height
Sash:	1No	W-274	N-179.5
	1No	W-274	M-179.5

GLASS SIZES:		Width	Height
Sash:	2No	Z-230	H-274

Note: All cutting Calculations are based on: Weld Allowance Not Included.
Variations may be experienced due to different weld burn-offs etc.

Note: Refer to Manufacturers Guide for general reinforcement specifications and recommendations.