

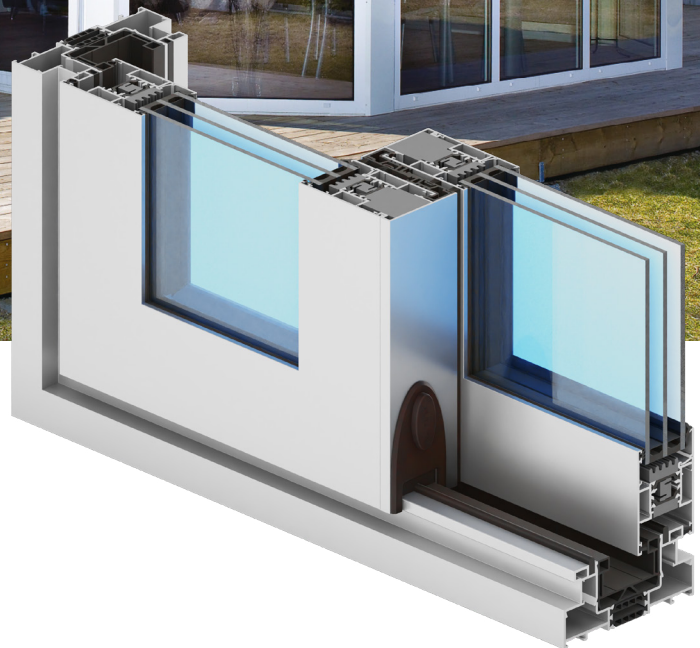

sliding system



Visoglide Plus

- system with increased thermal insulation performance used to design slide or lift-and-slide construction
- available options of the system: sliding and lift-and-slide; available versions of the system: monorail
- extremely narrow labyrinth stud in sliding and lift-and-slide leaves: 34 mm wide
- possible combinations of two, three, four and six elements on a two- or three-rail frame
- there is possibility of use: Flyscreen system and Insect System (fly screens are a practical and an extremely functional protection against insects)
- a wide range of colours – RAL palette (Qualicoat 1518), texture colours, Aliplast Wood Colour Effect (wood-like colours), Aliplast Loft View – colours imitating stone surfaces (Qualideco PL-0001), anodised colour (Qualanod 1808), bi-colour



sliding system

technical specification

system	material	depth of frame	depth of leaf	glazing range	weight of leaf	type of doors
VG Plus	aluminium/thermal insulation	118/142/184 mm	51 mm	6-36 mm; monorail option: 18-60 mm	to 250 kg in sliding option / to 200 kg lift-sliding option	sliding, lift-sliding

performance

system	thermal insulation Uf*	air permeability	windload resistance	watertightness
VG Plus	Uf from 2,1 W/m ² K	Class 4; EN 12207	Class C3/B4 (1200 Pa); EN 12210	Class 9A; EN 12208

* Thermal insulation is dependent on a combination of profiles and thickness of the filling.

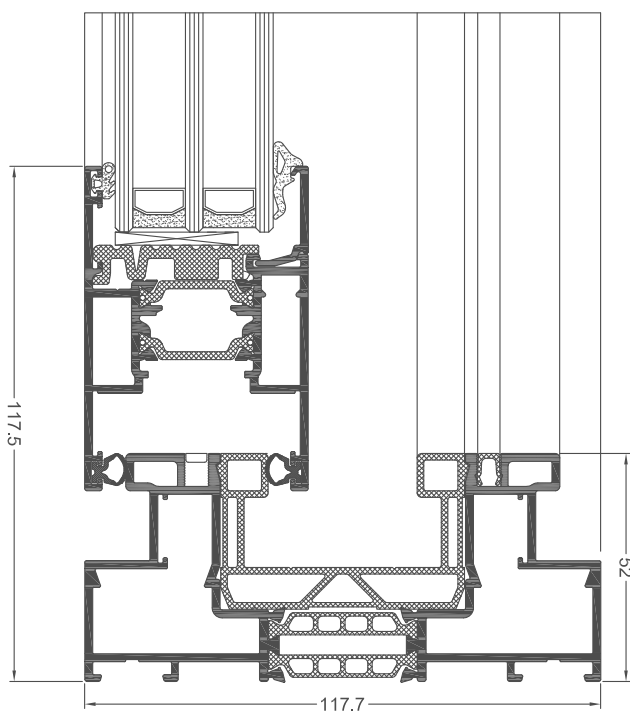

VG Plus cross section (VG1518 + VG520N)

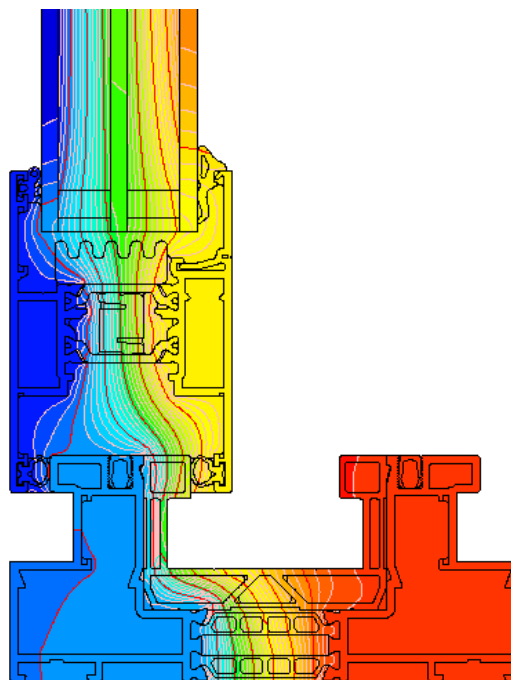

distribution of isotherms for frame with sash composition in the VG Plus system (VG1518 + VG520N)